

Plug-in Signal Conditioners M-UNIT

SIGNAL TRANSMITTER

(non-isolated)

Functions & Features

- Converting a DC input into a standard process signal
- LCD meter (engineering unit display selectable)
- Simple loop test output (0 % and 100 %)
- High-density mounting

Typical Applications

- mV, voltage and current scaling
- Buffer on a standard process signal line in order to increase load allowance (plus 500 Ω with 4 - 20 mA)

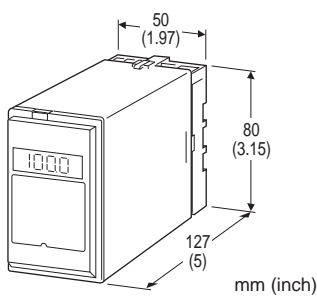

MODEL: CV-[1][2]-[3][4]

ORDERING INFORMATION

- Code number: CV-[1][2]-[3][4]
- Specify a code from below for each [1] through [4].
(e.g. CV-6A-B/E2/Q)
- Special input and output ranges (For codes Z & 0)
- Specify the specification for option code /Q
(e.g. /C01/S01)

[1] INPUT

Current

- A: 4 - 20 mA DC (Input resistance 250 Ω)
- A1: 4 - 20 mA DC (Input resistance 50 Ω)
- B: 2 - 10 mA DC (Input resistance 500 Ω)
- C: 1 - 5 mA DC (Input resistance 1000 Ω)
- D: 0 - 20 mA DC (Input resistance 50 Ω)
- E: 0 - 16 mA DC (Input resistance 62.5 Ω)
- F: 0 - 10 mA DC (Input resistance 100 Ω)
- G: 0 - 1 mA DC (Input resistance 1000 Ω)
- H: 10 - 50 mA DC (Input resistance 100 Ω)
- J: 0 - 10 μA DC (Input resistance 1000 Ω)
- K: 0 - 100 μA DC (Input resistance 1000 Ω)
- GW: -1 - +1 mA DC (Input resistance 1000 Ω)
- FW: -10 - +10 mA DC (Input resistance 100 Ω)

Z: Specify current (See INPUT SPECIFICATIONS)

Voltage

- 1: 0 - 10 mV DC (Input resistance 10 kΩ min.)
- 15: 0 - 50 mV DC (Input resistance 10 kΩ min.)
- 16: 0 - 60 mV DC (Input resistance 10 kΩ min.)
- 2: 0 - 100 mV DC (Input resistance 100 kΩ min.)
- 3: 0 - 1 V DC (Input resistance 1 MΩ min.)
- 4: 0 - 10 V DC (Input resistance 1 MΩ min.)
- 5: 0 - 5 V DC (Input resistance 1 MΩ min.)
- 6: 1 - 5 V DC (Input resistance 1 MΩ min.)
- 4W: -10 - +10 V DC (Input resistance 1 MΩ min.)
- 5W: -5 - +5 V DC (Input resistance 1 MΩ min.)
- 0: Specify voltage (See INPUT SPECIFICATIONS)

[2] OUTPUT

Current

- A: 4 - 20 mA DC (Load resistance 750 Ω max.)
- B: 2 - 10 mA DC (Load resistance 1500 Ω max.)
- C: 1 - 5 mA DC (Load resistance 3000 Ω max.)
- D: 0 - 20 mA DC (Load resistance 750 Ω max.)
- E: 0 - 16 mA DC (Load resistance 900 Ω max.)
- F: 0 - 10 mA DC (Load resistance 1500 Ω max.)
- G: 0 - 1 mA DC (Load resistance 15 kΩ max.)
- Z: Specify current (See OUTPUT SPECIFICATIONS)

Voltage

- 1: 0 - 10 mV DC (Load resistance 10 kΩ min.)
- 2: 0 - 100 mV DC (Load resistance 100 kΩ min.)
- 3: 0 - 1 V DC (Load resistance 100 Ω min.)
- 4: 0 - 10 V DC (Load resistance 1000 Ω min.)
- 5: 0 - 5 V DC (Load resistance 500 Ω min.)
- 6: 1 - 5 V DC (Load resistance 500 Ω min.)
- 4W: -10 - +10 V DC (Load resistance 2000 Ω min.)
- 5W: -5 - +5 V DC (Load resistance 1000 Ω min.)
- 0: Specify voltage (See OUTPUT SPECIFICATIONS)

[3] POWER INPUT

AC Power

- B: 100 V AC
- C: 110 V AC
- D: 115 V AC
- F: 120 V AC
- G: 200 V AC (Not selectable with Option /UL)
- H: 220 V AC (Not selectable with Option /UL)
- J: 240 V AC (Not selectable with Option /UL)

DC Power

- S: 12 V DC (Not selectable with Option /UL)
- R: 24 V DC (Not selectable with Option /UL)
- V: 48 V DC (Not selectable with Option /UL)
- P: 110 V DC (Not selectable with Option /E2 or /UL)



[4] OPTIONS (multiple selections)**Input Signal Indicator**

blank: Without

/E: With (0.0 - 100.0 % display)

/E2: With (in engineering unit with backlight and the simple loop test output)

Standards & Approvals

blank: Without UL

/UL: UL approval (Not selectable with /E or /E2)

Other Options

blank: none

/Q: Option other than the above (specify the specification)
(UL not available)**SPECIFICATIONS OF OPTION: Q (multiple selections)****COATING (For the detail, refer to M-System's web site.)**

/C01: Silicone coating

/C02: Polyurethane coating

/C03: Rubber coating

TERMINAL SCREW MATERIAL

/S01: Stainless steel

GENERAL SPECIFICATIONS

Construction: Plug-in

Connection: M3.5 screw terminals

Screw terminal: Chromated steel (standard) or stainless steel

Housing material: Flame-resistant resin (black)

Isolation: Input or output to power

Overrange output: Approx. -10 to +120 % at 1 - 5 V

Zero adjustment: -5 to +5 % (front)

Span adjustment: 95 to 105 % (front)

Display scaling: -10000 - +10000; ex-factory set to 0.00 - 100.00 (%)

Engineering unit: %, μ V, mV, V, mA, A, °C, °F, Ω , DEG K, mHz, Hz, kHz, VAC, AAC, mg, g, kg, t, rpm or rps selectable

Simple loop test output: 0 % and 100 % signal simulated by selecting the front switch positions.

INPUT SPECIFICATIONS**DC Current:**

Shunt resistor attached to the input terminals (0.5 W)

Specify input resistance value for code Z.

DC Voltage: -300 - +300 V DC

-30 - +30 V DC (span 30 V max.) for /UL

Minimum span: 3 mV

Offset: Max. 1.5 times span

Input resistanceSpan 3 - 10 mV : $\geq 10 \text{ k}\Omega$ Span 10 - 100 mV : $\geq 10 \text{ k}\Omega$ Span 0.1 - 1 V : $\geq 100 \text{ k}\Omega$ Span $\geq 1 \text{ V}$: $\geq 1 \text{ M}\Omega$ **OUTPUT SPECIFICATIONS**

■ DC Current: 0 - 20 mA DC

Minimum span: 1 mA

Offset: Max. 1.5 times span

Load resistance: Output drive 15 V max.

■ DC Voltage: -10 - +12 V DC

Minimum span: 5 mV

Offset: Max. 1.5 times span

Load resistance: Output drive 10 mA max.; 5 mA for negative voltage output; at $\geq 0.5 \text{ V}$ **INSTALLATION****Power input**•AC: Operational voltage range: rating $\pm 10 \%$, 50/60 ± 2 Hz, approx. 2 VA

(approx. 3 VA with Option /E2)

•DC: Operational voltage range: rating $\pm 10 \%$, or 85 - 150 V for 110 V rating (ripple 10 % p-p max.) approx. 2 W (80 mA at 24 V; approx. 3 W with Option /E2)

Operating temperature: -5 to +60°C (23 to 140°F)

Operating humidity: 30 to 90 %RH (non-condensing)

Mounting: Surface or DIN rail

Weight: 300 g (0.66 lbs)

PERFORMANCE in percentage of spanAccuracy: $\pm 0.1 \%$ Display accuracy: $\pm(0.1 \%$ of FS + 1 digit)Simple loop test output setting accuracy: $\pm 0.5 \%$ Temp. coefficient: $\pm 0.015 \%$ /°C ($\pm 0.008 \%$ /°F)Response time: ≤ 0.5 sec. (0 - 90 %)Line voltage effect: $\pm 0.1 \%$ over voltage rangeInsulation resistance: $\geq 100 \text{ M}\Omega$ with 500 V DC

Dielectric strength: 2000 V AC @1 minute (input or output to power to ground)

STANDARDS & APPROVALS**Approval:**

UL/C-UL general safety requirements

(UL 3111-1:1994, CAN/CSA-C22.2 No.1010-1:1992)



EXTERNAL VIEW

OPTION /E

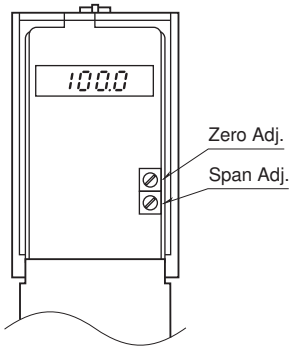

OPTION /E2

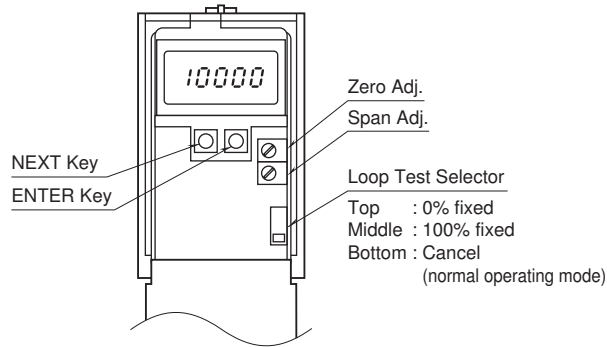

DIMENSIONS unit: mm (inch)

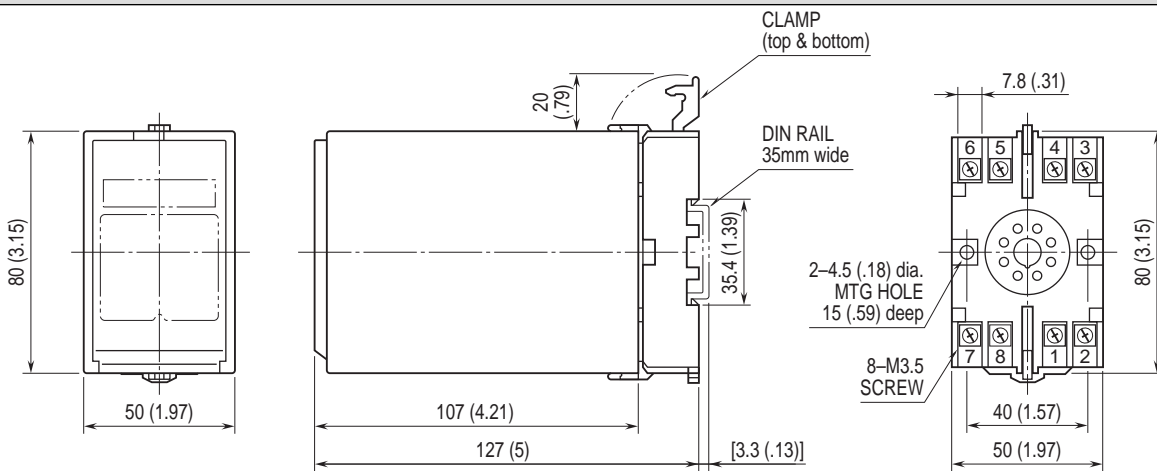

• When mounting, no extra space is needed between units.

TERMINAL ASSIGNMENTS unit: mm (inch)

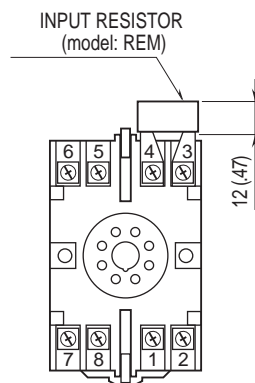

Input shunt resistor attached for current input.

SCHEMATIC CIRCUITRY & CONNECTION DIAGRAM

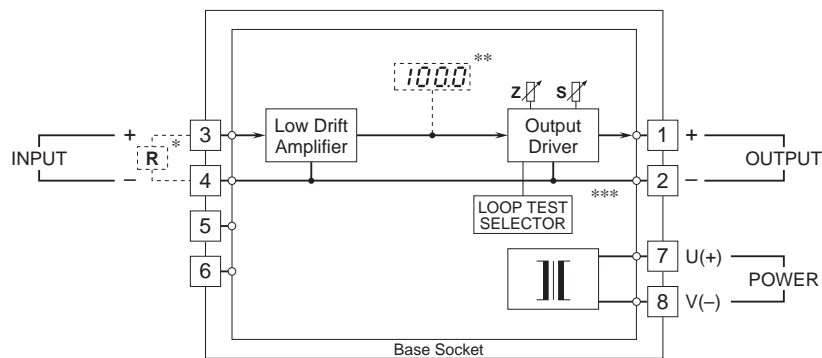

* Input shunt resistor attached for current input.

** Option /E, E2

*** Option /E2



Specifications are subject to change without notice.

