

Plug-in Signal Conditioners M-UNIT

HIGH AC CURRENT TRANSMITTER

(wide bandwidth; clamp-on current sensor)

Functions & Features

- Converts an alternating current into a standard process signal
- Easy-to-install clamp-on type current sensor without needing a current transformer
- Clamp-on current sensor included
- Wide input range from 10 A up to 400 A
- Wide frequency band can be accepted
- Over-voltage clamp element for safety in open circuit
- LCD meter (engineering unit display selectable)
- Simple loop test output (0 % and 100 %)
- High-density mounting

Typical Applications

- Measurement in tight places as never before possible
- Monitoring load current of motors employing inverters
- Detecting failures of a pump or other device by monitoring abnormal load current of motors
- Monitoring current of electric welding machine

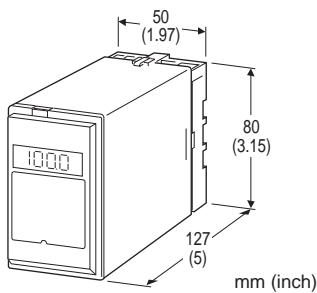

MODEL: CTCS-[1][2][3]-[4][5]

ORDERING INFORMATION

- Code number: CTCS-[1][2][3]-[4][5]
- Specify a code from below for each [1] through [5]. (e.g. CTCS-1100A-C/E2/Q)
- Special output range (For codes Z & 0)
- Specify the specification for option code /Q (e.g. /C01/S01)

[1] SENSOR

- 1: Leadwire type CLSA
- 2: Screw terminal type CLSB

[2] INPUT

- 10: 0 - 10 A AC
- 15: 0 - 15 A AC
- 20: 0 - 20 A AC
- 30: 0 - 30 A AC
- 40: 0 - 40 A AC
- 50: 0 - 50 A AC
- 60: 0 - 60 A AC
- 75: 0 - 75 A AC
- 100: 0 - 100 A AC
- 125: 0 - 125 A AC
- 150: 0 - 150 A AC
- 175: 0 - 175 A AC
- 200: 0 - 200 A AC
- 225: 0 - 225 A AC
- 250: 0 - 250 A AC
- 300: 0 - 300 A AC
- 350: 0 - 350 A AC
- 400: 0 - 400 A AC (Not selectable with the sensor type code 2 'Screw terminal type CLSB')

[3] OUTPUT

Current

- A: 4 - 20 mA DC (Load resistance 750 Ω max.)
- B: 2 - 10 mA DC (Load resistance 1500 Ω max.)
- C: 1 - 5 mA DC (Load resistance 3000 Ω max.)
- D: 0 - 20 mA DC (Load resistance 750 Ω max.)
- E: 0 - 16 mA DC (Load resistance 900 Ω max.)
- F: 0 - 10 mA DC (Load resistance 1500 Ω max.)
- G: 0 - 1 mA DC (Load resistance 15 kΩ max.)
- Z: Specify current (See OUTPUT SPECIFICATIONS)

Voltage

- 1: 0 - 10 mV DC (Load resistance 10 kΩ min.)
- 2: 0 - 100 mV DC (Load resistance 100 kΩ min.)
- 3: 0 - 1 V DC (Load resistance 100 Ω min.)
- 4: 0 - 10 V DC (Load resistance 1000 Ω min.)
- 5: 0 - 5 V DC (Load resistance 500 Ω min.)
- 6: 1 - 5 V DC (Load resistance 500 Ω min.)
- 4W: -10 - +10 V DC (Load resistance 2000 Ω min.)
- 5W: -5 - +5 V DC (Load resistance 1000 Ω min.)
- 0: Specify voltage (See OUTPUT SPECIFICATIONS)

[4] POWER INPUT

AC Power

- B: 100 V AC
- C: 110 V AC
- D: 115 V AC
- F: 120 V AC
- G: 200 V AC
- H: 220 V AC
- J: 240 V AC



DC Power

S: 12 V DC

R: 24 V DC

V: 48 V DC

P: 110 V DC (Not selectable with Option /E2)

[5] OPTIONS (multiple selections)

Input Signal Indicator

blank: Without

/E: With (0.0 - 100.0 % display)

/E2: With (in engineering unit with backlight and the simple loop test output)

Other Options

blank: none

/Q: Option other than the above (specify the specification)

SPECIFICATIONS OF OPTION: Q (multiple selections)

COATING (For the detail, refer to M-System's web site.)

/C01: Silicone coating

/C02: Polyurethane coating

/C03: Rubber coating

TERMINAL SCREW MATERIAL

/S01: Stainless steel

ACCESSORIES

The clamp-on current sensor is included in the product package.

■ CLAMP-ON CURRENT SENSOR (leadwire type CLSA)

• 0 - 10 A through 0 - 75 A Use

Sensor model No.: CLSA-08

Sensor cable model No.: CLSA-08C-30

Applicable cable diameter: Max. 10.0

Sensor leadwire: AWG 22

Weight: 45 g (1.6 oz)

• 0 - 100 A Use

Sensor model No.: CLSA-12

Sensor cable model No.: CLSA-08C-30

Applicable cable diameter: Max. 16.0

Sensor leadwire: AWG 22

Weight: 70 g (2.5 oz)

• 0 - 125 A through 0 - 300 A Use

Sensor model No.: CLSA-30

Applicable cable diameter: Max. 24.0

Sensor leadwire: AWG 18, 200 mm

Weight: 200 g (7.1 oz)

• 0 - 350 A through 0 - 400 A Use

Sensor model No.: CLSA-50

Applicable cable diameter: Max. 36.0

Sensor leadwire: AWG 18, 200 mm

Weight: 300 g (10.6 oz)

■ CLAMP-ON CURRENT SENSOR (screw terminal type CLSB)

Connection: M3 screw terminal (torque 0.5 N·m)

Screw terminal: Nickel-plated steel

Output wiring: Use AWG22 or thicker wires for the output.

Twist the paired wires, extendable up to 30 meters.

• 0 - 10 A through 0 - 50 A Use

Sensor model No.: CLSB-05

Applicable cable diameter: Max. 10.0

Weight: 45 g (1.6 oz)

• 0 - 60 A through 0 - 100 A Use

Sensor model No.: CLSB-10

Applicable cable diameter: Max. 16.0

Weight: 80 g (2.8 oz)

• 0 - 125 A through 0 - 200 A Use

Sensor model No.: CLSB-20

Applicable cable diameter: Max. 24.0

Weight: 200 g (7.1 oz)

• 0 - 225 A through 0 - 350 A Use

Sensor model No.: CLSB-40

Applicable cable diameter: Max. 35.0

Weight: 300 g (10.6 oz)

Note 1: The output values may vary depending on the accuracy of engagement at the clamp connection.

Note 2: The sensor is detachable up to 100 times (approx.).

Note 3: The sensor's mechanical construction may cause it to generate resonance sound. However, it does not affect the performance of the sensor.

GENERAL SPECIFICATIONS

Construction: Plug-in

Connection: M3.5 screw terminals

Screw terminal: Chromated steel (standard) or stainless steel

Housing material: Flame-resistant resin (black)

Isolation: Sensor core to sensor output or input to output to power

Overrange output: 0 to 120 % at 1 - 5 V

Zero adjustment: -5 to +5 % (front)

Span adjustment: 95 to 105 % (front)

Display scaling: -10000 - +10000; ex-factory set to 0.00 - 100.00 (%)

Engineering unit: %, μ V, mV, V, mA, A, °C, °F, Ω , DEG K, mHz, Hz, kHz, VAC, AAC, mg, g, kg, t, rpm or rps selectable

Simple loop test output: 0 % and 100 % signal simulated by selecting the front switch positions.

INPUT SPECIFICATIONS

Frequency: 4 Hz - 10 kHz

Overload capacity

CLSA - 08: 120 A continuous

CLSA - 12: 300 A continuous

CLSA - 30: 360 A continuous



CLSA - 50: 600 A continuous

CLSB - 05: 100 A continuous

CLSB - 10: 200 A continuous

CLSB - 20: 300 A continuous

CLSB - 40: 600 A continuous

(input to output to power to ground)

1000 V AC @1 minute

(sensor core to sensor output)

Operational range: 0 - 120 % of rating

Be sure that the input voltage is of 440 V or less.

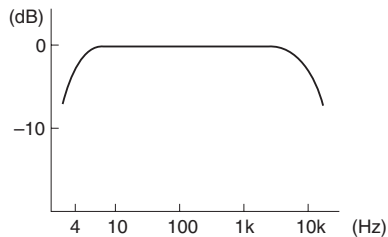

Frequency Characteristics Example

OUTPUT SPECIFICATIONS

■ **DC Current:** 0 - 20 mA DC

Minimum span: 1 mA

Offset: Max. 1.5 times span

Load resistance: Output drive 15 V max.

■ **DC Voltage:** -10 - +12 V DC

Minimum span: 5 mV

Offset: Max. 1.5 times span

Load resistance: Output drive 10 mA max.; 5 mA for negative voltage output; at ≥ 0.5 V

INSTALLATION

Power input

• **AC:** Operational voltage range: rating ± 10 %, 50/60 ± 2 Hz, approx. 3 VA

• **DC:** Operational voltage range: rating ± 10 %, or 85 - 150 V

for 110 V rating (ripple 10 % p-p max.) approx. 2 W (80 mA at 24 V; approx. 3 W with Option /E2)

Operating temperature: -5 to +60°C (23 to 140°F)

Operating humidity: 30 to 90 %RH (non-condensing)

Mounting: Surface or DIN rail

Weight: 400 g (Except clamp-on current sensor)

PERFORMANCE in percentage of span

Accuracy: ± 1.5 % (20 - 500 Hz)

Display accuracy: $\pm (1.5$ % of FS + 1 digit)

Simple loop test output setting accuracy: ± 0.5 %

Temp. coefficient: ± 0.015 %/°C (± 0.008 %/°F)

Response time: ≤ 0.5 sec. (0 - 90 %)

Ripple: 0.5 %p-p max.

Line voltage effect: ± 0.1 % over voltage range

Insulation resistance: ≥ 100 M Ω with 500 V DC

Dielectric strength: 2000 V AC @1 minute



幸託有限公司

XIN TOP CORPORATION

TEL : (02)2598-1199

FAX : (02)2596-2331

E-mail : info@xintop.com

Website : www.xintop.com

EXTERNAL VIEW

OPTION /E

OPTION /E2

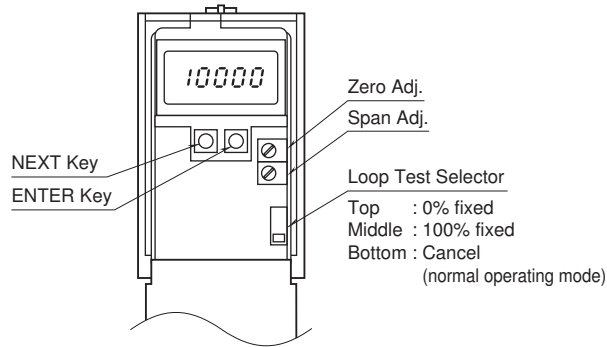
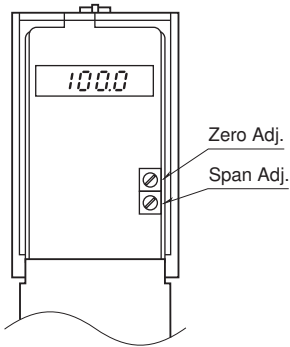

EXTERNAL DIMENSIONS & TERMINAL ASSIGNMENTS unit: mm (inch)

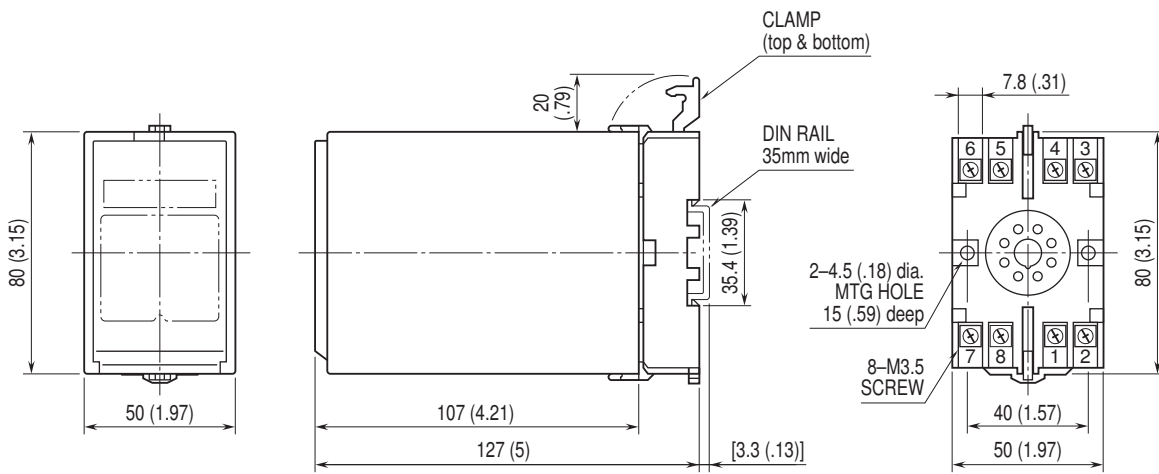

■ Sensor model No.: CLSA-08

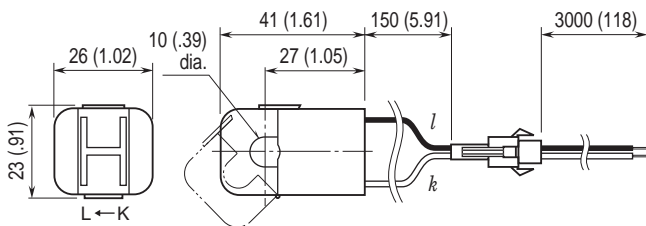

■ Sensor model No.: CLSA-30

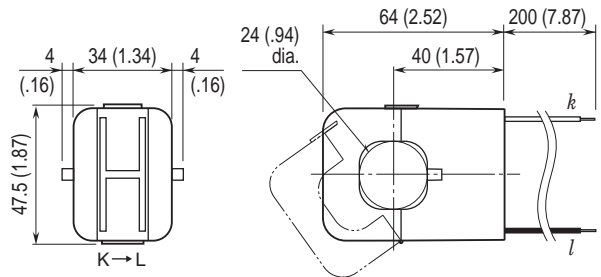

■ Sensor model No.: CLSA-12

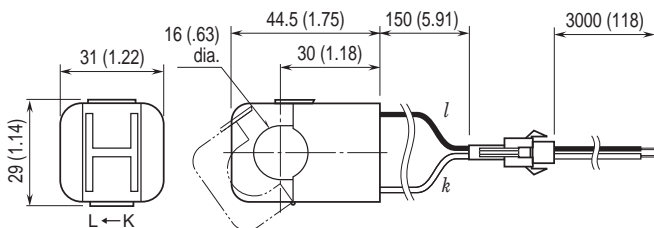

■ Sensor model No.: CLSA-50

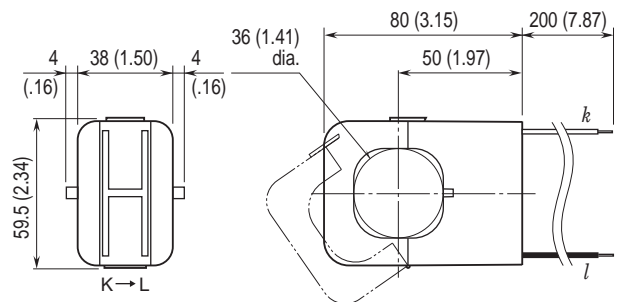

■ Sensor model No.: CLSB-05

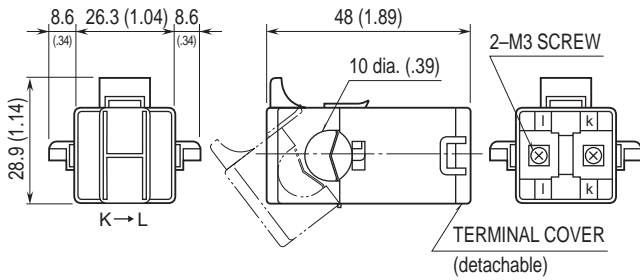

■ Sensor model No.: CLSB-10

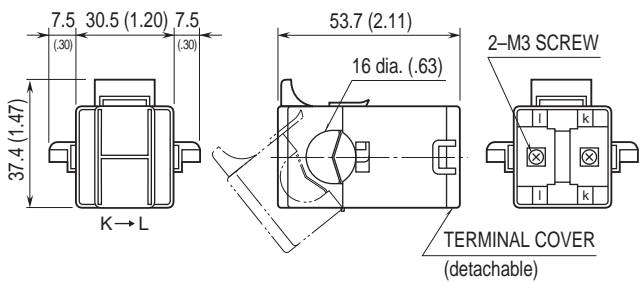

■ Sensor model No.: CLSB-20

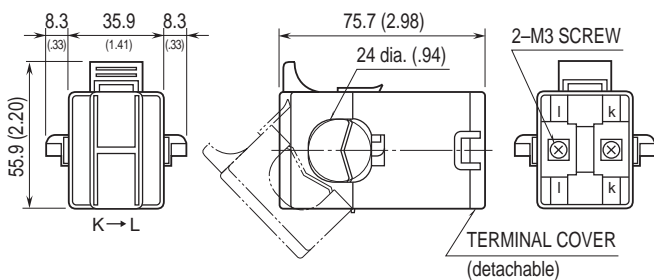

■ Sensor model No.: CLSB-40

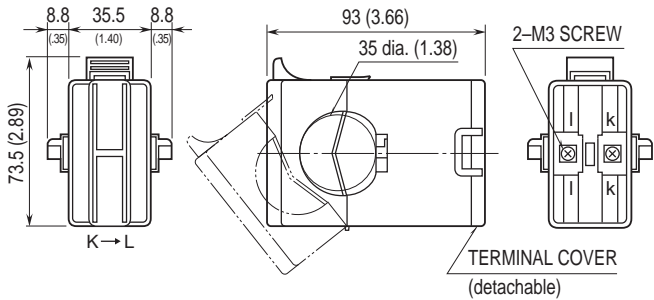

SCHEMATIC CIRCUITRY & CONNECTION DIAGRAM

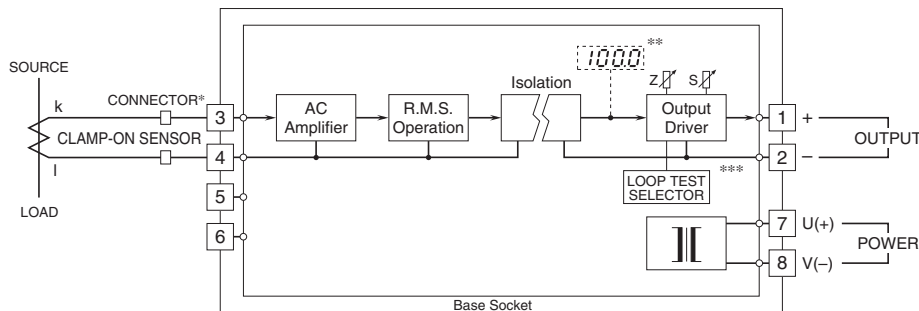

* Connector provided only for the CLSA-08 and CLSA-12.
 ** Option /E, E2
 *** Option /E2





Specifications are subject to change without notice.

