

Plug-in Signal Conditioners M-UNIT

CT TRANSMITTER

Functions & Features

- Converting an alternating current from a current transformer into a standard process signal
- Minimum ripple
- True RMS sensing
- CT Protector provided for open-circuit protection
- Isolation up to 2000 V AC
- LCD meter (engineering unit display selectable)
- Simple loop test output (0 % and 100 %)
- High-density mounting

Typical Applications

- Centralized monitoring and control of motors, pumps or heaters by DCS
- Monitoring power line and power supply current

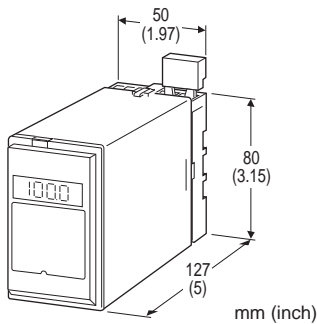

MODEL: CT-[1][2]-[3][4]

ORDERING INFORMATION

- Code number: CT-[1][2]-[3][4]
- Specify a code from below for each [1] through [4]. (e.g. CT-1A-B/E2/Q)
- Special output range (For codes Z & 0)
- Specify the specification for option code /Q (e.g. /C01/S01)

[1] INPUT

Current

- 1: 0 - 1 A AC
- 5: 0 - 5 A AC

[2] OUTPUT

Current

- A: 4 - 20 mA DC (Load resistance 750 Ω max.)
- B: 2 - 10 mA DC (Load resistance 1500 Ω max.)
- C: 1 - 5 mA DC (Load resistance 3000 Ω max.)

- D: 0 - 20 mA DC (Load resistance 750 Ω max.)
- E: 0 - 16 mA DC (Load resistance 900 Ω max.)
- F: 0 - 10 mA DC (Load resistance 1500 Ω max.)
- G: 0 - 1 mA DC (Load resistance 15 kΩ max.)
- Z: Specify current (See OUTPUT SPECIFICATIONS)

Voltage

- 1: 0 - 10 mV DC (Load resistance 10 kΩ min.)
- 2: 0 - 100 mV DC (Load resistance 100 kΩ min.)
- 3: 0 - 1 V DC (Load resistance 100 Ω min.)
- 4: 0 - 10 V DC (Load resistance 1000 Ω min.)
- 5: 0 - 5 V DC (Load resistance 500 Ω min.)
- 6: 1 - 5 V DC (Load resistance 500 Ω min.)
- 4W: -10 - +10 V DC (Load resistance 2000 Ω min.)
- 5W: -5 - +5 V DC (Load resistance 1000 Ω min.)
- 0: Specify voltage (See OUTPUT SPECIFICATIONS)

[3] POWER INPUT

AC Power

- B: 100 V AC
- C: 110 V AC
- D: 115 V AC
- F: 120 V AC
- G: 200 V AC
- H: 220 V AC
- J: 240 V AC

DC Power

- S: 12 V DC
- R: 24 V DC
- V: 48 V DC
- P: 110 V DC (Not selectable with Option /E2)

[4] OPTIONS (multiple selections)

Input Signal Indicator

- blank: Without
- /E: With (0.0 - 100.0 % display)
- /E2: With (in engineering unit with backlight and the simple loop test output)

Other Options

- blank: none
- /Q: Option other than the above (specify the specification)

SPECIFICATIONS OF OPTION: Q (multiple selections)

COATING (For the detail, refer to M-System's web site.)

- /C01: Silicone coating
- /C02: Polyurethane coating
- /C03: Rubber coating

TERMINAL SCREW MATERIAL

- /S01: Stainless steel



GENERAL SPECIFICATIONS

Construction: Plug-in
Connection: M3.5 screw terminals
Screw terminal: Chromated steel (standard) or stainless steel
Housing material: Flame-resistant resin (black)
Isolation: Input to output to power
Input waveform: Up to 15 % of 3rd harmonic content
Overrange output: 0 to 120 % at 1 - 5 V
Zero adjustment: -5 to +5 % (front)
Span adjustment: 95 to 105 % (front)
Display scaling: -10000 - +10000; ex-factory set to 0.00 - 100.00 (%)
Engineering unit: %, μ V, mV, V, mA, A, °C, °F, Ω , DEG K, mHz, Hz, kHz, VAC, AAC, mg, g, kg, t, rpm or rps selectable
Simple loop test output: 0 % and 100 % signal simulated by selecting the front switch positions.

INPUT SPECIFICATIONS

Frequency: 50 or 60 Hz
Input burden:
 \leq 0.1 VA (input 0 - 1 A)
 \leq 0.5 VA (input 0 - 5 A)
Overload capacity: 500 % of rating for 5 sec., 120 % continuous
Operational range: 0 - 120 % of rating

OUTPUT SPECIFICATIONS

■ **DC Current:** 0 - 20 mA DC
Minimum span: 1 mA
Offset: Max. 1.5 times span
Load resistance: Output drive 15 V max.
■ **DC Voltage:** -10 - +12 V DC
Minimum span: 5 mV
Offset: Max. 1.5 times span
Load resistance: Output drive 10 mA max.; 5 mA for negative voltage output; at \geq 0.5 V

INSTALLATION

Power input
• **AC:** Operational voltage range: rating \pm 10 %, 50/60 \pm 2 Hz, approx. 2 VA
(approx. 3 VA with Option /E2)
• **DC:** Operational voltage range: rating \pm 10 %, or 85 - 150 V for 110 V rating (ripple 10 % p-p max.) approx. 2 W (80 mA at 24 V; approx. 3 W with Option /E2)
Operating temperature: -5 to +60°C (23 to 140°F)
Operating humidity: 30 to 90 %RH (non-condensing)
Mounting: Surface or DIN rail
Weight: 350 g (0.77 lb)

PERFORMANCE in percentage of span

Accuracy: \pm 0.3 %
Display accuracy: \pm (0.3 % of FS + 1 digit)
Simple loop test output setting accuracy: \pm 0.5 %
Temp. coefficient: \pm 0.015 %/°C (\pm 0.008 %/°F)
Response time: \leq 0.5 sec. (0 - 90 %)
Ripple: 0.5 %p-p max.
Line voltage effect: \pm 0.1 % over voltage range
Insulation resistance: \geq 100 M Ω with 500 V DC
Dielectric strength: 2000 V AC @1 minute (input to output to power to ground)



EXTERNAL VIEW

OPTION /E

OPTION /E2

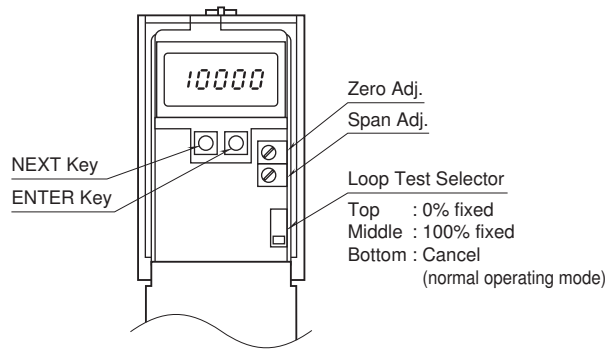
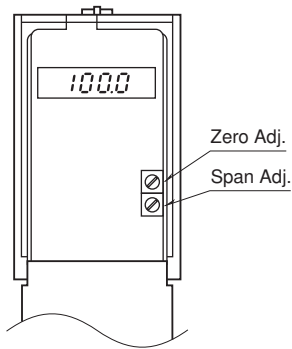

DIMENSIONS unit: mm (inch)

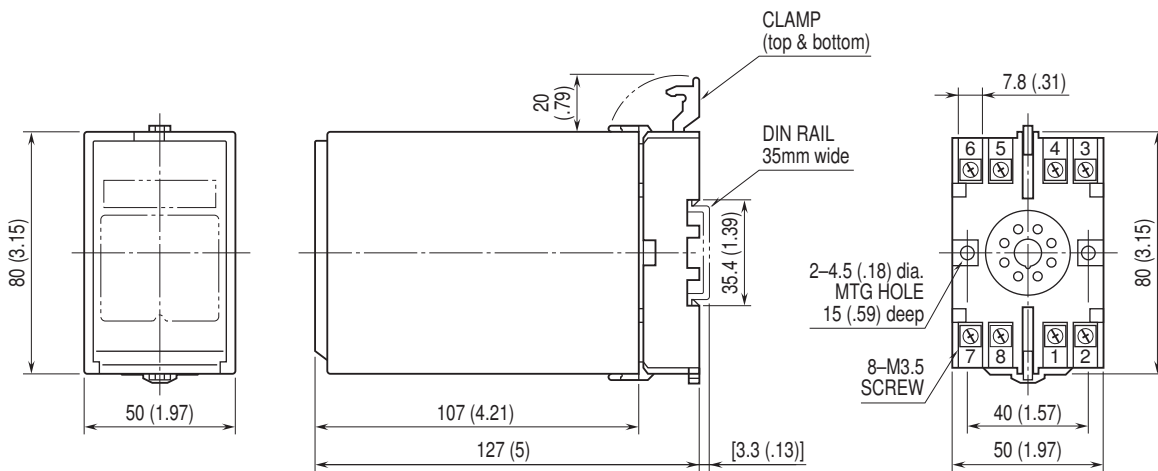

• When mounting, no extra space is needed between units.

TERMINAL ASSIGNMENTS unit: mm (inch)

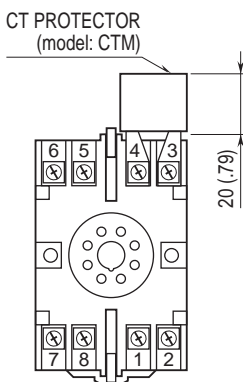

SCHEMATIC CIRCUITRY & CONNECTION DIAGRAM

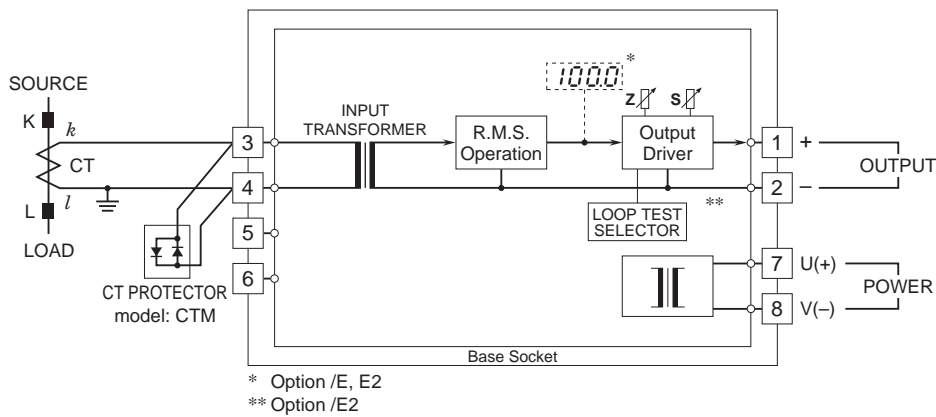

Specifications are subject to change without notice.

