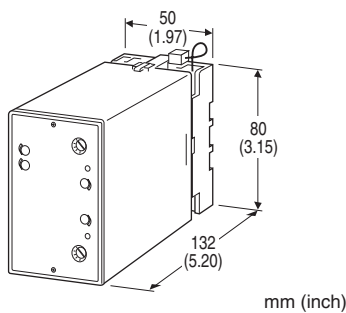

Limit Alarms (potentiometer adj.) A-UNIT**THERMOCOUPLE ALARM****Functions & Features**

- Providing SPDT relay outputs at preset input levels
- Direct input from a thermocouple
- Dual (Hi/Lo) trip
- Burnout protection
- High-accuracy cold junction compensation
- Energized or de-energized coil at a tripped condition selectable
- Hysteresis (deadband) adjustable
- Enclosed relays
- Relays can be powered 110 V DC
- High-density mounting

Typical Applications

- Annunciator
- Various alarm applications

**MODEL: ATC-[1]1[2][3]-[4][5]****ORDERING INFORMATION**

- Code number: ATC-[1]1[2][3]-[4][5]
Specify a code from below for each [1] through [5].
(e.g. ATC-2111-B/BL)
- Temperature range (e.g. 0 - 800°C)

[1] INPUT THERMOCOUPLE

- 1: (PR) (Usable Range 0 to 1760°C, 32 to 3200°F)
- 2: K (CA) (Usable range -270 to +1370°C, -454 to +2498°F)
- 3: E (CRC) (Usable range -270 to +1000°C, -454 to +1832°F)
- 4: J (IC) (Usable range -210 to +1200°C, -346 to +2192°F)
- 5: T (CC) (Usable range -270 to +400°C, -454 to +752°F)
- 6: B (RH) (Usable range 0 to 1820°C, 32 to 3308°F)
- 7: R (Usable range -50 to +1760°C, -58 to +3200°F)
- 8: S (Usable range -50 to +1760°C, -58 to +3200°F)
- N: N (Usable range -270 to +1300°C, -454 to +2372°F)
- 0: Specify

[2] SETPOINT 1 OUTPUT

- 1: Hi (coil energized at alarm)
- 2: Hi (coil de-energized at alarm)
- 3: Lo (coil energized at alarm)
- 4: Lo (coil de-energized at alarm)

[3] SETPOINT 2 OUTPUT

- 1: Hi (coil energized at alarm)
- 2: Hi (coil de-energized at alarm)
- 3: Lo (coil energized at alarm)
- 4: Lo (coil de-energized at alarm)

[4] POWER INPUT**AC Power**

- B: 100 V AC
- C: 110 V AC
- D: 115 V AC
- F: 120 V AC
- G: 200 V AC
- H: 220 V AC
- J: 240 V AC

DC Power

- S: 12 V DC
- R: 24 V DC
- V: 48 V DC
- P: 110 V DC

[5] OPTIONS**Burnout**

- blank: Upscale burnout
- /BL: Downscale burnout
- /BN: No burnout

GENERAL SPECIFICATIONS**Construction:** Plug-in**Connection:** M3.5 screw terminals**Housing material:** Flame-resistant resin (black)**Isolation:** Input to output 1 to output 2 to power**Zero adjustment:** -5 to +5 % (front)**Span adjustment:** 95 to 105 % (front)**Setpoint adjustments:** 270°-turn screwdriver adjustments (front); 0 - 100 % independently**Hysteresis (deadband) adjustments:** 1 - 100 % (front)**Linearization:** Not provided**Cold junction compensation:** CJC sensor attached to the input terminals**Front LEDs:** Lights turn on at a tripped condition; red for output 1, green for output 2**Power ON timer:** Relays de-energized for approx. 2 seconds after power is turned on.

INPUT SPECIFICATIONS

Minimum span: 3 mV
Offset: Max. 1.5 times span
Input resistance: 30 kΩ min.
Burnout sensing: 0.1 μA

Minimum span (in °C)
(PR): min. span 370°C
K (CA): min. span 75°C
E (CRC): min. span 50°C
J (IC): min. span 60°C
T (CC): min. span 75°C
B (RH): min. span 780°C
R: min. span 360°C
S: min. span 380°C
N: min. span 110°C

Minimum span (in °F)
(PR): min. span 670°F
K (CA): min. span 140°F
E (CRC): min. span 90°F
J (IC): min. span 110°F
T (CC): min. span 140°F
B (RH): min. span 1410°F
R: min. span 650°F
S: min. span 690°F
N: min. span 200°F

OUTPUT SPECIFICATIONS

■ **Relay Contact:** 100 V AC @ 1 A (cos φ = 1)
 120 V AC @ 1 A (cos φ = 1)
 240 V AC @ 0.5 A (cos φ = 1)
 30 V DC @ 1 A (resistive load)
Maximum switching voltage: 380 V AC or 125 V DC
Maximum switching power: 120 VA or 30 W
Minimum load: 5 V DC @ 10 mA
Mechanical life: 5 x 10⁷ cycles
 For maximum relay life with inductive loads, external protection is recommended.

Alarm Trip Operation Terminal No. in parentheses

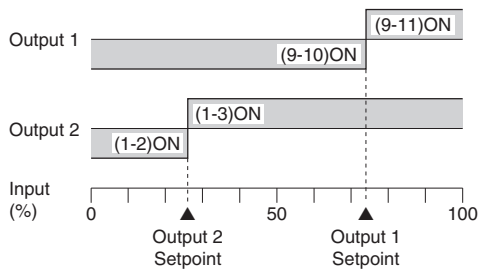

Trip Operation in Power Failure

- **Output Code: 1 & 4:** Terminals 1 – 2, 9 – 10 turn ON
- **Output Code: 2 & 3:** Terminals 1 – 3, 9 – 11 turn ON

INSTALLATION

Power input
 • **AC:** Operational voltage range: rating ±10 %, 50/60 ±2 Hz, approx. 2 VA
 • **DC:** Operational voltage range: rating ±10 %, or 85 – 150 V for 110 V rating (ripple 10 % p-p max.)
 Approx. 2 W (80 mA at 24 V)
Operating temperature: -5 to +60°C (23 to 140°F)
Operating humidity: 30 to 90 %RH (non-condensing)
Mounting: Surface or DIN rail
Weight: 450 g (0.99 lbs)

PERFORMANCE in percentage of span

Trip point repeatability: ±0.5 %
Cold junction compensation error
 (at 20°C ±10°C or 68°F ±18°F)
K, E, J, T & N: ±0.5°C or ±0.9°F
S, R & PR: ±1°C or ±1.8°F
Temp. coefficient: ±0.05 %/°C (±0.03 %/°F)
Response time: ≤ 0.5 sec. (0 – 100 % at 90 % setpoint)
Burnout response: ≤ 10 sec.
Line voltage effect: ±0.1 % over voltage range
Insulation resistance: ≥ 100 MΩ with 500 V DC
Dielectric strength: 2000 V AC @1 minute (input to output 1 to output 2 to power to ground)



EXTERNAL VIEW

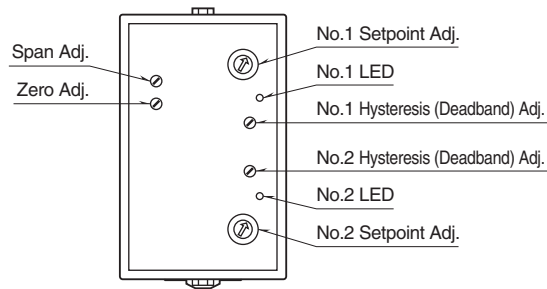

DIMENSIONS unit: mm (inch)

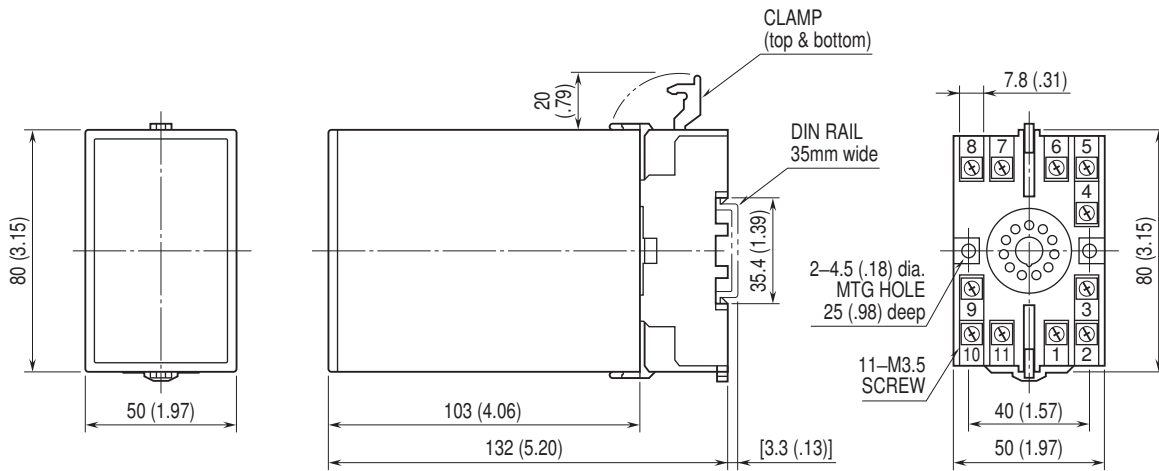

• When mounting, no extra space is needed between units.

TERMINAL ASSIGNMENTS unit: mm (inch)

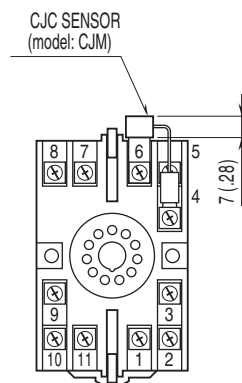

SCHEMATIC CIRCUITRY & CONNECTION DIAGRAM

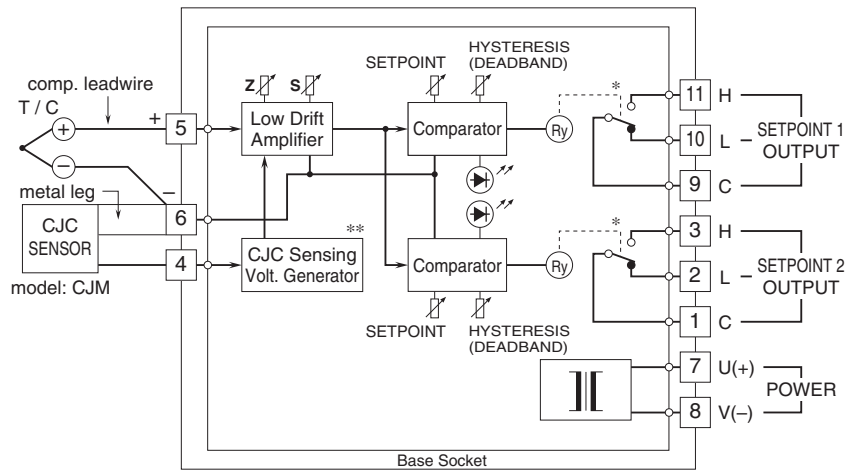

* Relay status for output codes "1" & "4", at power OFF.
 **Deleted with B thermocouple

Relay Protection

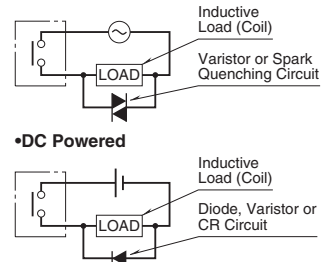

Specifications are subject to change without notice.