

Plug-in Signal Conditioners M-UNIT

DC ALARM

Functions & Features

- Providing relay contact closures at preset DC input levels
- Dual (Hi/Lo) trip
- Multi-turn screwdriver setpoint adjustments
- Monitor jacks provided for setpoint adjustments
- Enclosed relays
- Relays can be powered 110 V DC
- Isolation up to 2000 V AC
- High-density mounting

Typical Applications

- Annunciator
- Various alarm applications

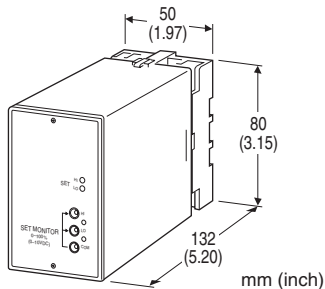

MODEL: ASW-[1]-[2][3]

ORDERING INFORMATION

- Code number: ASW-[1]-[2][3]
- Specify a code from below for each [1] through [3].
(e.g. ASW-6-H/Q)
- Special input range (For codes Z & 0)
- Specify the specification for option code /Q
(e.g. /C01/S01)

[1] INPUT

Current

- A: 4 - 20 mA DC (Input resistance 250 Ω)
- A1: 4 - 20 mA DC (Input resistance 50 Ω)
- B: 2 - 10 mA DC (Input resistance 500 Ω)
- C: 1 - 5 mA DC (Input resistance 1000 Ω)
- D: 0 - 20 mA DC (Input resistance 50 Ω)
- E: 0 - 16 mA DC (Input resistance 62.5 Ω)
- F: 0 - 10 mA DC (Input resistance 100 Ω)
- G: 0 - 1 mA DC (Input resistance 1000 Ω)
- H: 10 - 50 mA DC (Input resistance 100 Ω)
- J: 0 - 10 μA DC (Input resistance 1000 Ω)
- K: 0 - 100 μA DC (Input resistance 1000 Ω)
- GW: -1 - +1 mA DC (Input resistance 1000 Ω)

FW: -10 - +10 mA DC (Input resistance 100 Ω)

Z: Specify current (See INPUT SPECIFICATIONS)

Voltage

- 1: 0 - 10 mV DC (Input resistance 10 kΩ min.)
- 15: 0 - 50 mV DC (Input resistance 10 kΩ min.)
- 16: 0 - 60 mV DC (Input resistance 10 kΩ min.)
- 2: 0 - 100 mV DC (Input resistance 100 kΩ min.)
- 3: 0 - 1 V DC (Input resistance 1 MΩ min.)
- 4: 0 - 10 V DC (Input resistance 1 MΩ min.)
- 5: 0 - 5 V DC (Input resistance 1 MΩ min.)
- 6: 1 - 5 V DC (Input resistance 1 MΩ min.)
- 4W: -10 - +10 V DC (Input resistance 1 MΩ min.)
- 5W: -5 - +5 V DC (Input resistance 1 MΩ min.)
- 0: Specify voltage (See INPUT SPECIFICATIONS)

OUTPUT

Relay; SPDT or transfer contact

[2] POWER INPUT

AC Power

- B: 100 V AC
- C: 110 V AC
- D: 115 V AC
- F: 120 V AC
- G: 200 V AC
- H: 220 V AC
- J: 240 V AC

DC Power

- S: 12 V DC
- R: 24 V DC
- V: 48 V DC
- P: 110 V DC

[3] OPTIONS

/Q: With options (specify the specification)

SPECIFICATIONS OF OPTION: Q (multiple selections)

COATING (For the detail, refer to M-System's web site.)

- /C01: Silicone coating
- /C02: Polyurethane coating
- /C03: Rubber coating

TERMINAL SCREW MATERIAL

- /S01: Stainless steel

GENERAL SPECIFICATIONS

Construction: Plug-in

Connection: M3.5 screw terminals

Screw terminal: Chromated steel (standard) or stainless steel

Housing material: Flame-resistant resin (black)



Isolation: Input to output to power
Setpoint adjustments: Multi-turn screwdriver adjustments (front); 0 - 100% independently
Monitor jacks: Output 0 - 10 V for 0 - 100 % setpoints
Hysteresis (deadband): 0.5 - 1.0 %
Front LEDs: Red lights turn on when the coils are energized.
Power ON timer: Relays de-energized for approx. 2 seconds after power is turned on.

for 110 V rating (ripple 10 % p-p max.)
 Approx. 2 W (80 mA at 24 V)
Operating temperature: -5 to +60°C (23 to 140°F)
Operating humidity: 30 to 90 %RH (non-condensing)
Mounting: Surface or DIN rail
Weight: 400 g (0.88 lbs)

PERFORMANCE in percentage of span

Setpoint monitor accuracy: ± 0.5 %
Temp. coefficient: ±0.015 %/°C (±0.008 %/°F)
Response time: ≤ 0.5 sec. (0 - 100 % at 90 % setpoint)
Line voltage effect: ±0.1 % over voltage range
Insulation resistance: ≥ 100 MΩ with 500 V DC
Dielectric strength: 2000 V AC @1 minute (input to output to power to ground)

INPUT SPECIFICATIONS

■ **DC Current:**
 Shunt resistor attached to the input terminals (0.5 W)
 Specify input resistance value for code Z.
 ■ **DC Voltage:** -300 - +300 V DC
Minimum span: 10 mV
Offset: Max. 1.5 times span
Input resistance
 Span 10 - 100 mV : ≥ 10 kΩ
 Span 0.1 - 1 V : ≥ 100 kΩ
 Span ≥ 1 V : ≥ 1 MΩ

OUTPUT SPECIFICATIONS

■ **Relay Contact:** 100 V AC @1 A (cos φ = 1)
 120 V AC @1 A (cos φ = 1)
 240 V AC @0.5 A (cos φ = 1)
 30 V DC @1 A (resistive load)
Maximum switching voltage: 380 V AC or 125 V DC
Maximum switching power: 120 VA or 30 W
Minimum load: 5 V DC @10 mA
Mechanical life: 5 × 10⁷ cycles
 For maximum relay life with inductive loads, external protection is recommended.

Alarm Trip Operation Terminal No. in parentheses

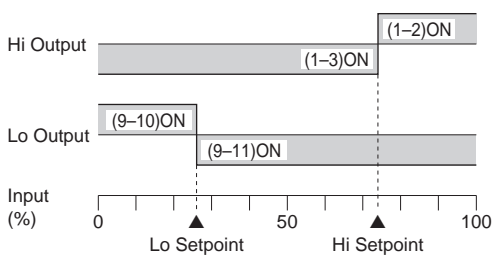

Trip Operation in Power Failure
 : Terminals 1 - 3, 9 - 11 turn ON.

INSTALLATION

Power input
 • **AC:** Operational voltage range: rating ±10 %, 50/60 ±2 Hz, approx. 2 VA
 • **DC:** Operational voltage range: rating ±10 %, or 85 - 150 V



幸託有限公司
 XIN TOP CORPORATION

TEL : (02)2598-1199
 FAX : (02)2596-2331

E-mail : info@xintop.com
 Website : www.xintop.com

EXTERNAL VIEW

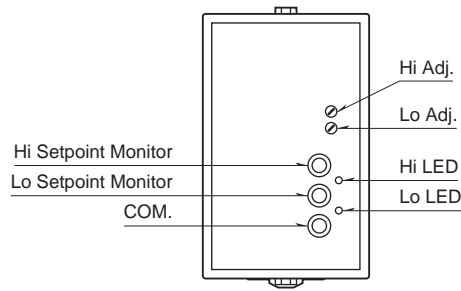

DIMENSIONS unit: mm (inch)

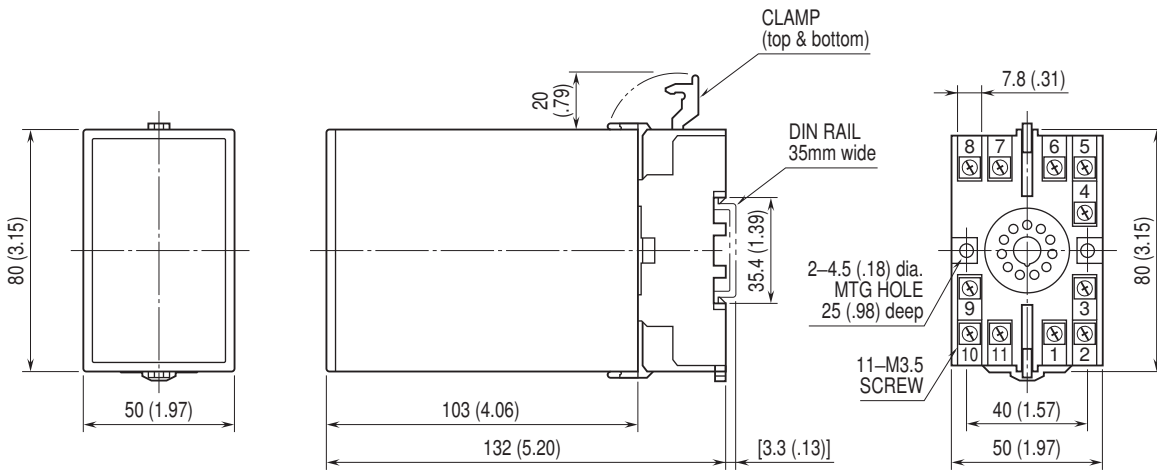

• When mounting, no extra space is needed between units.

TERMINAL ASSIGNMENTS unit: mm (inch)

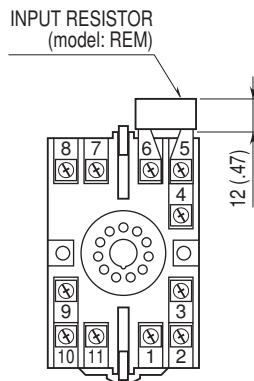

Input shunt resistor attached for current input.

SCHEMATIC CIRCUITRY & CONNECTION DIAGRAM

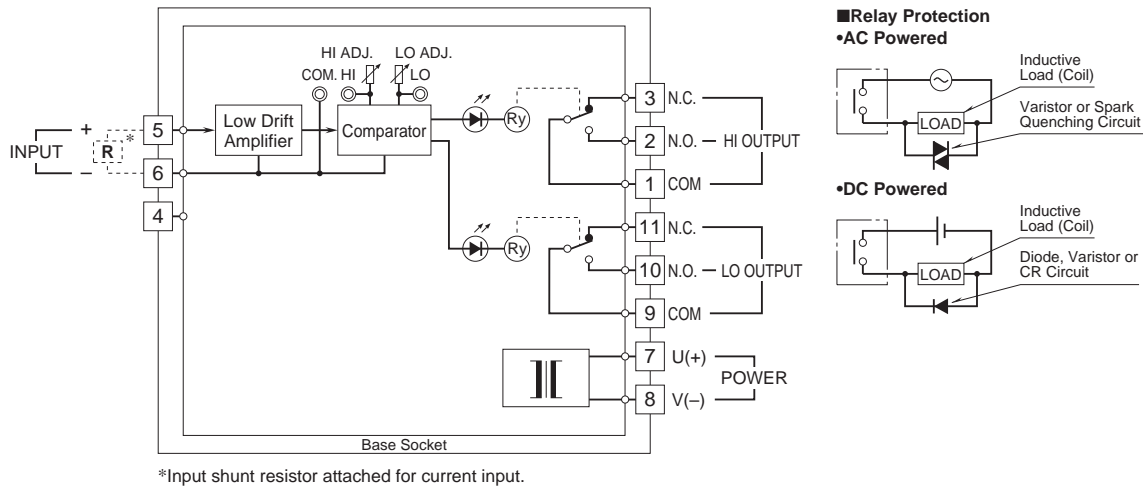

Specifications are subject to change without notice.

