

## Plug-in Signal Conditioners M-UNIT

### RTD ALARM

(dual or quad alarm trip; field-configurable)

#### Functions & Features

- Provides relay outputs at preset temperature levels
- Quad or dual trip
- Setting and display in engineering unit values
- Setpoint adjustments with the front keypad
- Software lock
- Adjustable hysteresis (deadband)
- On-delay timer
- Hi/Lo trip and energized/de-energized coil independently selectable for each setpoint
- Enclosed relays
- Relays can be powered by 200 V AC and 100 V DC
- High-density mounting on DIN rail

#### Typical Applications

- Annunciator
- Various alarm applications

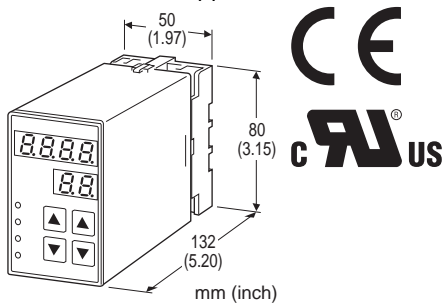

### MODEL: AS4R-[1]-[2][3]

#### ORDERING INFORMATION

- Code number: AS4R-[1]-[2][3]
- Specify a code from below for each [1] through [3]. (e.g. AS4R-2-R/Q)
- Specify the specification for option code /Q (e.g. /C01/S01/SET)

#### [1] OUTPUT

- 2: 4 points; N.O. or make contact
- 3: 4 points; N.C. or break contact
- 5: 2 points; SPDT or transfer contact

#### [2] POWER INPUT

##### AC Power

**M2:** 100 - 240 V AC (Operational voltage range 85 - 264 V, 47 - 66 Hz)  
(90 - 264 V for UL)

##### DC Power

**R:** 24 V DC  
(Operational voltage range 24 V  $\pm$ 10 %, ripple 10 %p-p max.)  
**P:** 110 V DC  
(Operational voltage range 85 - 150 V, ripple 10 %p-p max.)  
(110 V  $\pm$ 10 % for UL)

### [3] OPTIONS (multiple selections)

#### Standards & Approvals

**blank:** CE marking  
**/UL:** UL approval, CE marking

#### Temperature Range

**blank:** -5 to +55°C  
**/T:** Wide operating temperature range -25 to +55°C  
(Option /T is Not selectable with UL approval.)

**blank:** none

**/Q:** With options (specify the specification)  
(UL not available)

#### SPECIFICATIONS OF OPTION: Q (multiple selections)

##### COATING (For the detail, refer to M-System's web site.)

**/C01:** Silicone coating  
**/C02:** Polyurethane coating  
**/C03:** Rubber coating

##### TERMINAL SCREW MATERIAL

**/S01:** Stainless steel

##### EX-FACTORY SETTING

**/SET:** Preset according to the Ordering Information Sheet  
(No. ESU-1606)

#### GENERAL SPECIFICATIONS

**Construction:** Plug-in

**Connection:** M3.5 screw terminals

**Screw terminal:** Chromated steel (standard) or stainless steel

**Housing material:** Flame-resistant resin (black)

**Isolation:** Input to output to power

**Burnout:** Upscale standard; downscale optional by programming

**Sampling cycle:** 100 msec.

**User-configurable items:** Front keypad

- Alarm setpoint
- Power ON-delay time
- Alarm ON-delay time
- Moving average
- Hi/Lo trip operation
- Coil at alarm
- Hysteresis (deadband)
- Temperature limit
- Temperature unit
- RTD type



• Others

(Refer to the instruction manual)

■ DISPLAY

LED: 8 mm (.31") 7 segment, red

Number of display digits: 4 digits for DATA display;

2 digits for ITEM display

PV indication: Temperature in engineering unit

Overrange indication: LEDs blinking

Power saving mode: Displays turn off if the keys are untouched for a preset time period

LEDs: Red lights turn on when coils are energized.

(L1 and L2 for 2-point alarm. L1, L2, L3 and L4 for 4-point alarm.)

## INPUT SPECIFICATIONS

Maximum leadwire resistance: 200 Ω per wire (3-wire)

Sensing current: ≤ 1.0 mA

Default setting: Pt 100 (JIS '97, IEC) -100 - +500°C

Temperature range

RTD	USABLE RANGE	
	°C	°F
JPt 100 (JIS '89)	-235 to +560	-391 to +1040
Pt 100 (JIS '89)	-240 to +900	-400 to +1652
Pt 100 (JIS '97, IEC)	-240 to +900	-400 to +1652
Pt 50Ω (JIS '81)	-235 to +700	-391 to +1292
Ni 508.4Ω	-100 to +330	-148 to +572
Pt 1000	-240 to +900	-400 to +1652
Ni 100	-100 to +250	-148 to +482
Cu 10 @ 25 °C	-210 to +310	-346 to +590

## OUTPUT SPECIFICATIONS

■ Quad Alarm

Relay rating:

120 V AC @ 1 A (cos φ = 1)

240 V AC @ 0.5 A (cos φ = 1)

30 V DC @ 1 A (resistive load)

Maximum switching voltage: 380 V AC or 125 V DC

Maximum switching power: 120 VA or 30 W

Minimum load: 5 V DC @ 10 mA

Mechanical life: 5 × 10<sup>7</sup> cycles

• Dual Alarm

Relay rating:

120 V AC @ 5 A (cos φ = 1)

240 V AC @ 2.5 A (cos φ = 1)

30 V DC @ 5 A (resistive load)

Maximum switching voltage: 380 V AC or 125 V DC

Maximum switching power: 600 VA or 150 W

Minimum load: 5 V DC @ 10 mA

Mechanical life: 5 × 10<sup>7</sup> cycles

### Alarm Trip Operation

Terminal No. in parentheses

Example with quad N.O. contacts (LL, L, H, HH)

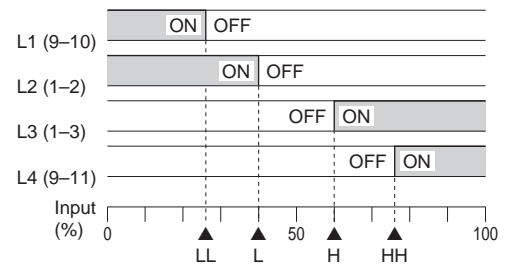

### Trip Operation in Power Failure

- Output code 2: All relays turn off.
- Output code 3: All relays turn on.
- Output code 5: Terminals 1 - 3, 9 - 11 turn on.

## INSTALLATION

### Power Consumption

•AC: Approx. 6 VA

•DC: Approx. 3.5 W

Operating humidity: 30 to 90 %RH (non-condensing)

Mounting: Surface or DIN rail

Weight: 500 g (1.1 lbs)

## PERFORMANCE in percentage of FS input

### Setpoint accuracy (trip point accuracy):

±(0.1% of FS + 1 digit)

±(0.2% of FS + 1 digit) for Cu 10

Display accuracy: ±(0.1 % of FS + 1 digit)

Temp. coefficient: ±0.015 %/°C (±0.008 %/°F)

Response time: ≤ 1.5 sec. (0 - 100 % at 90 % setpoint)

Burnout response: ≤ 5 sec.

Line voltage effect: ±0.1 % over voltage range

Insulation resistance: ≥ 100 MΩ with 500 V DC

Dielectric strength: 2000 V AC @1 minute (input to output to power to ground)

## STANDARDS & APPROVALS

### CE conformity:

EMC Directive (2004/108/EC)

EMI EN 61000-6-4: 2007

EMS EN 61000-6-2: 2005

Low Voltage Directive (2006/95/EC)

EN 61010-1: 2001

Measurement Category II (output)

Installation Category II (power)

Pollution Degree 2

Input to output to power - Basic insulation (300 V)

### Approval:

UL/C-UL general safety requirements

(UL 3111-1:1994, CAN/CSA-C22.2 No.1010-1:1992)



幸託有限公司  
XIN TOP CORPORATION

TEL : (02)2598-1199

FAX : (02)2596-2331

E-mail : info@xintop.com

Website : www.xintop.com

## EXTERNAL VIEW

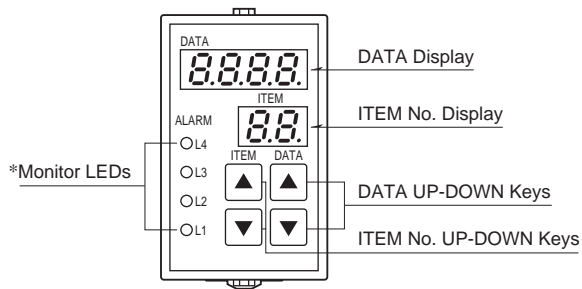

\*L3 or L4 does not turn on for dual output type.

Refer to the instruction manual for detailed procedures.

## DIMENSIONS unit: mm (inch)

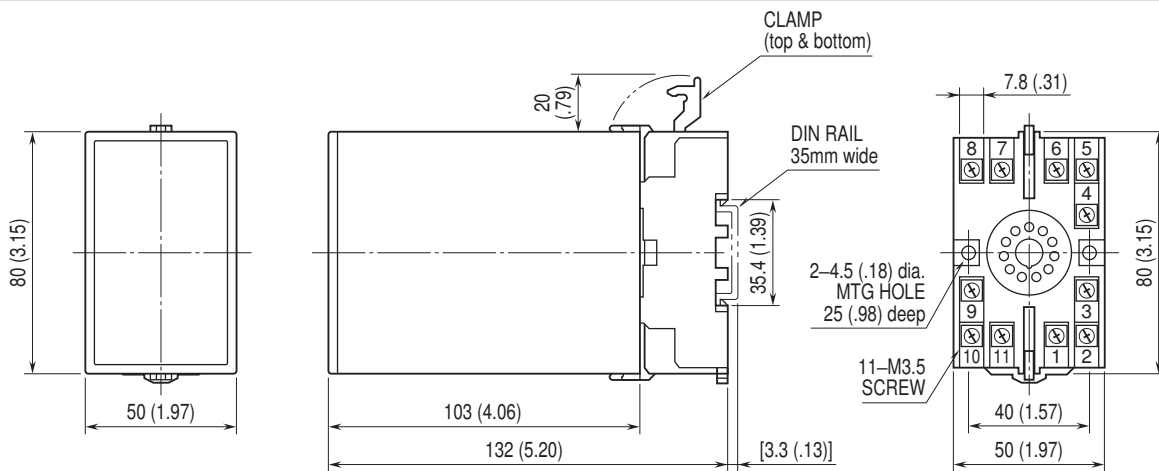

• When mounting, no extra space is needed between units.



## SCHEMATIC CIRCUITRY & CONNECTION DIAGRAM

### ■ OUTPUT SUFFIX CODE: 2

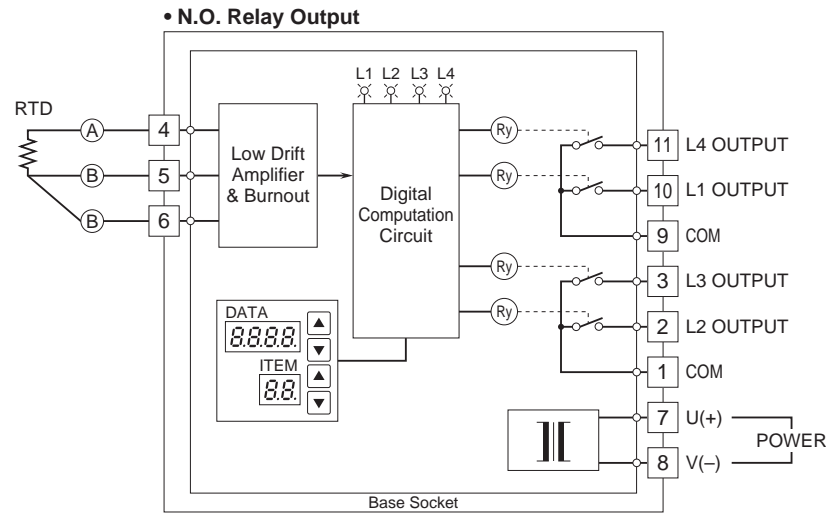

### ■ OUTPUT SUFFIX CODE: 3

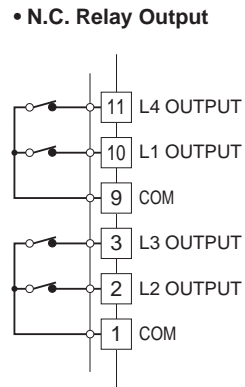

### ■ OUTPUT SUFFIX CODE: 5

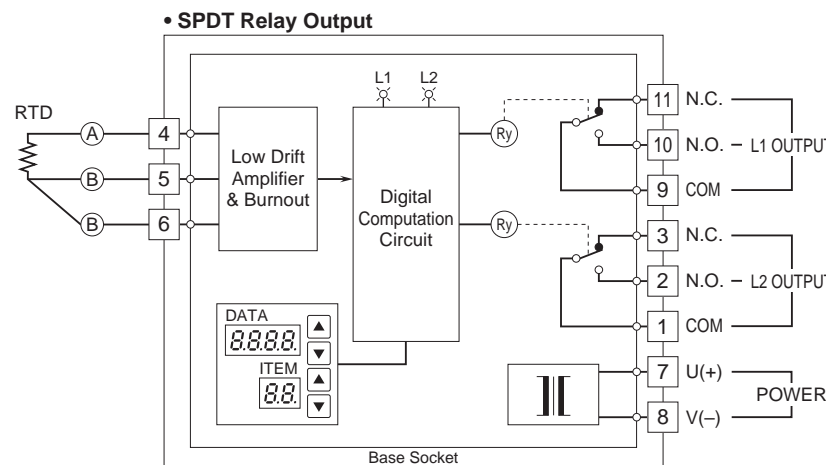

### ■ Relay Protection

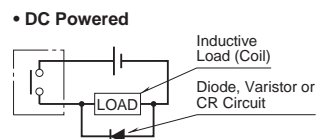
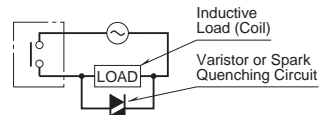

Specifications are subject to change without notice.