

Limit Alarms (rotary switch adj.) AL-UNIT

DC ALARM

Functions & Features

- Providing SPDT relay outputs at preset DC input levels
- Dual (Hi/Lo) trip
- Energized or de-energized coil at a tripped condition selectable
- Rotary switch setpoint adjustments
- Enclosed relays
- Relays can be powered 110 V DC
- Isolation up to 2000 V AC
- High-density mounting

Typical Applications

- Annunciator
- Various alarm applications

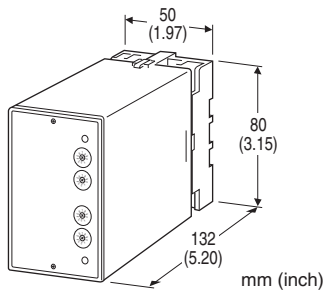

MODEL: ALV-[1][2][3]-[4]

ORDERING INFORMATION

- Code number: ALV-[1][2][3]-[4]
- Specify a code from below for each [1] through [4]. (e.g. ALV-A13-B)
- Special input range (For codes Z & 0)

[1] INPUT

Current

- A: 4 - 20 mA DC (Input resistance 250 Ω)
- A1: 4 - 20 mA DC (Input resistance 50 Ω)
- B: 2 - 10 mA DC (Input resistance 500 Ω)
- C: 1 - 5 mA DC (Input resistance 1000 Ω)
- D: 0 - 20 mA DC (Input resistance 50 Ω)
- E: 0 - 16 mA DC (Input resistance 62.5 Ω)
- F: 0 - 10 mA DC (Input resistance 100 Ω)
- G: 0 - 1 mA DC (Input resistance 1000 Ω)
- H: 10 - 50 mA DC (Input resistance 100 Ω)
- J: 0 - 10 μ A DC (Input resistance 1000 Ω)
- K: 0 - 100 μ A DC (Input resistance 1000 Ω)
- GW: -1 - +1 mA DC (Input resistance 1000 Ω)

FW: -10 - +10 mA DC (Input resistance 100 Ω)

Z: Specify current (See INPUT SPECIFICATIONS)

Voltage

- 1: 0 - 10 mV DC (Input resistance 10 k Ω min.)
- 15: 0 - 50 mV DC (Input resistance 10 k Ω min.)
- 16: 0 - 60 mV DC (Input resistance 10 k Ω min.)
- 2: 0 - 100 mV DC (Input resistance 100 k Ω min.)
- 3: 0 - 1 V DC (Input resistance 1 M Ω min.)
- 4: 0 - 10 V DC (Input resistance 1 M Ω min.)
- 5: 0 - 5 V DC (Input resistance 1 M Ω min.)
- 6: 1 - 5 V DC (Input resistance 1 M Ω min.)
- 4W: -10 - +10 V DC (Input resistance 1 M Ω min.)
- 5W: -5 - +5 V DC (Input resistance 1 M Ω min.)
- 0: Specify voltage (See INPUT SPECIFICATIONS)

[2] SETPOINT 1 OUTPUT

- 1: Hi (coil energized at alarm)
- 2: Hi (coil de-energized at alarm)
- 3: Lo (coil energized at alarm)
- 4: Lo (coil de-energized at alarm)

[3] SETPOINT 2 OUTPUT

- 1: Hi (coil energized at alarm)
- 2: Hi (coil de-energized at alarm)
- 3: Lo (coil energized at alarm)
- 4: Lo (coil de-energized at alarm)

[4] POWER INPUT

AC Power

- B: 100 V AC
- C: 110 V AC
- D: 115 V AC
- F: 120 V AC
- G: 200 V AC
- H: 220 V AC
- J: 240 V AC

DC Power

- S: 12 V DC
- R: 24 V DC
- V: 48 V DC
- P: 110 V DC



GENERAL SPECIFICATIONS

Construction: Plug-in
Connection: M3.5 screw terminals
Housing material: Flame-resistant resin (black)
Isolation: Input to output 1 to output 2 to power
Setpoint adjustments: 10-position rotary switches (front); 0 - 99 % independently; 1 % increments
Hysteresis (deadband): 0.7 - 2.5 %
Front LEDs: Red lights turn on when the coils are energized.
Power ON timer: Relays de-energized for approx. 2 seconds after power is turned on.

INPUT SPECIFICATIONS

■ **DC Current:**
 Shunt resistor attached to the input terminals (0.5 W)
 Specify input resistance value for code Z.
 ■ **DC Voltage:** -300 - +300 V DC
Minimum span: 10 mV
Offset: Max. 1.5 times span
Input resistance
 Span 10 - 100 mV : $\geq 10 \text{ k}\Omega$
 Span 0.1 - 1 V : $\geq 100 \text{ k}\Omega$
 Span $\geq 1 \text{ V}$: $\geq 1 \text{ M}\Omega$

OUTPUT SPECIFICATIONS

■ **Relay Contact:** 100 V AC @ 1 A ($\cos \phi = 1$)
 120 V AC @ 1 A ($\cos \phi = 1$)
 240 V AC @ 0.5 A ($\cos \phi = 1$)
 30 V DC @ 1 A (resistive load)
Maximum switching voltage: 380 V AC or 125 V DC
Maximum switching power: 120 VA or 30 W
Minimum load: 5 V DC @ 10 mA
Mechanical life: 5×10^7 cycles
 For maximum relay life with inductive loads, external protection is recommended.

Alarm Trip Operation Terminal No. in parentheses

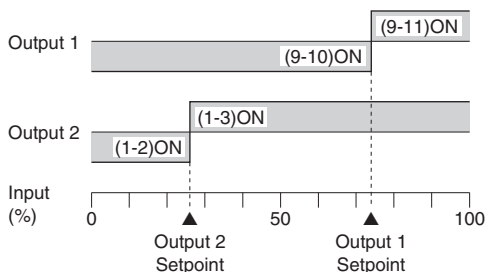

Trip Operation in Power Failure

- **Output Code: 1 & 4:** Terminals 1 - 2, 9 - 10 turn ON
- **Output Code: 2 & 3:** Terminals 1 - 3, 9 - 11 turn ON

INSTALLATION

Power input
 • **AC:** Operational voltage range: rating ± 10 %, 50/60 ± 2 Hz, approx. 2 VA
 • **DC:** Operational voltage range: rating ± 10 %, or 85 - 150 V for 110 V rating (ripple 10 % p-p max.)
 Approx. 2 W (80 mA at 24 V)
Operating temperature: -5 to +60°C (23 to 140°F)
Operating humidity: 30 to 90 %RH (non-condensing)
Mounting: Surface or DIN rail
Weight: 370 g (0.82 lbs)

PERFORMANCE in percentage of span

Setpoint accuracy: ± 0.5 %
Trip point repeatability: ± 0.05 %
Temp. coefficient: ± 0.015 %/°C (± 0.008 %/°F)
Response time: Approx. 0.5 sec. (0 - 100 % at 90 % setpoint)
Line voltage effect: ± 0.1 % over voltage range
Insulation resistance: $\geq 100 \text{ M}\Omega$ with 500 V DC
Dielectric strength: 2000 V AC @1 minute (input to output 1 to output 2 to power to ground)



EXTERNAL VIEW

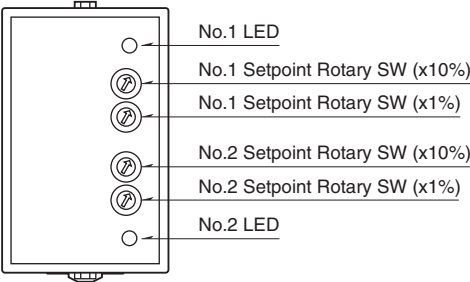

DIMENSIONS unit: mm (inch)

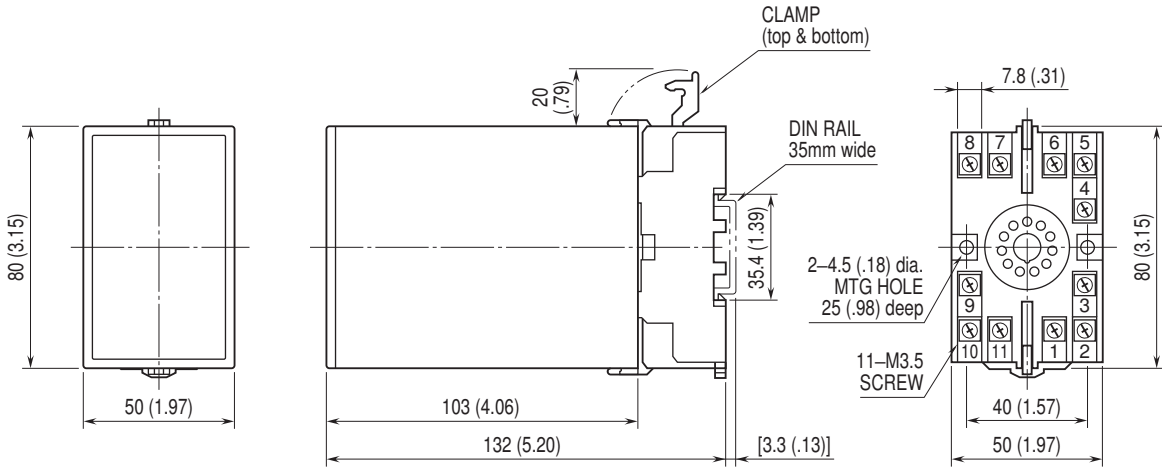

• When mounting, no extra space is needed between units.

TERMINAL ASSIGNMENTS unit: mm (inch)

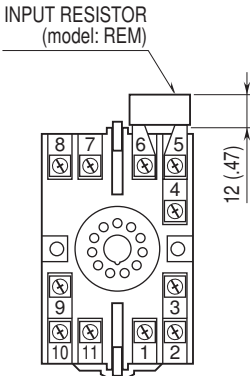

Input shunt resistor attached for current input.



SCHEMATIC CIRCUITRY & CONNECTION DIAGRAM

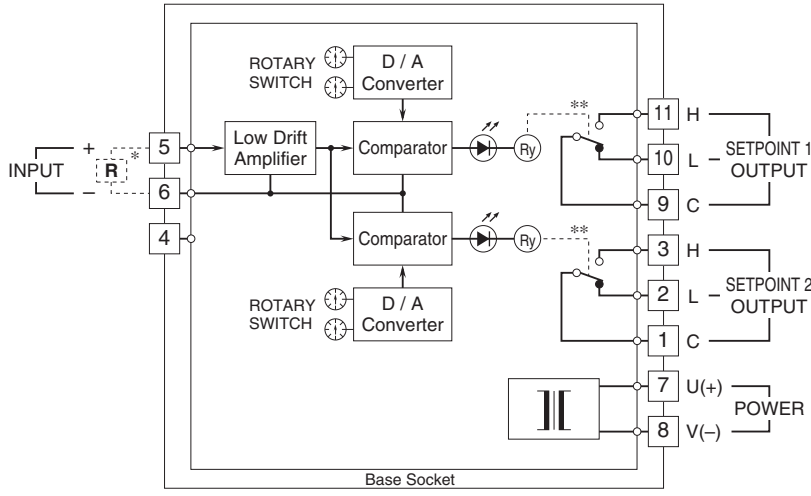

* Input shunt resistor attached for current input.
 **Relay status for output codes "1" & "4", at power OFF.

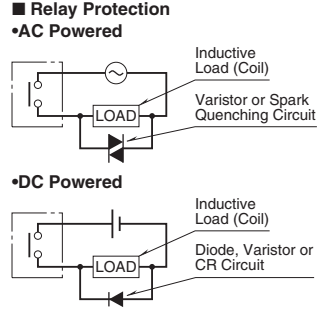

Specifications are subject to change without notice.

