

**Limit Alarms (rotary switch adj.) AL-UNIT**

**THERMOCOUPLE ALARM**

**Functions & Features**

- Providing SPDT relay outputs at preset input levels
- Direct input from a thermocouple
- Dual (Hi/Lo) trip
- 7-segment linearization
- Burnout protection
- High-accuracy cold junction compensation
- Energized or de-energized coil at a tripped condition selectable
- Rotary switch setpoint adjustments
- Enclosed relays
- Relays can be powered 110 V DC
- High-density mounting

**Typical Applications**

- Annunciator
- Various alarm applications

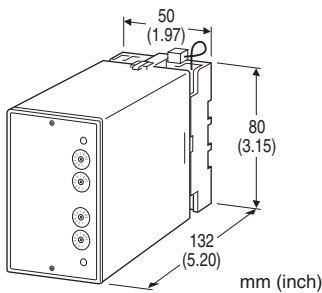

**MODEL: ALT-[1][2][3]-[4][5]**

**ORDERING INFORMATION**

- Code number: ALT-[1][2][3]-[4][5]
- Specify a code from below for each [1] through [5]. (e.g. ALT-221-B/BN)
- Temperature range (e.g. 0 – 800°C)

**[1] INPUT THERMOCOUPLE**

- 1: (PR) (Usable Range 0 to 1760°C, 32 to 3200°F)
- 2: K (CA) (Usable range -270 to +1370°C, -454 to +2498°F)
- 3: E (CRC) (Usable range -270 to +1000°C, -454 to +1832°F)
- 4: J (IC) (Usable range -210 to +1200°C, -346 to +2192°F)
- 5: T (CC) (Usable range -270 to +400°C, -454 to +752°F)
- 6: B (RH) (Usable range 0 to 1820°C, 32 to 3308°F)
- 7: R (Usable range -50 to +1760°C, -58 to +3200°F)
- 8: S (Usable range -50 to +1760°C, -58 to +3200°F)
- N: N (Usable range -270 to +1300°C, -454 to +2372°F)
- 0: Specify

**[2] SETPOINT 1 OUTPUT**

- 1: Hi (coil energized at alarm)
- 2: Hi (coil de-energized at alarm)
- 3: Lo (coil energized at alarm)
- 4: Lo (coil de-energized at alarm)

**[3] SETPOINT 2 OUTPUT**

- 1: Hi (coil energized at alarm)
- 2: Hi (coil de-energized at alarm)
- 3: Lo (coil energized at alarm)
- 4: Lo (coil de-energized at alarm)

**[4] POWER INPUT**

- AC Power**
- B: 100 V AC
- C: 110 V AC
- D: 115 V AC
- F: 120 V AC
- G: 200 V AC
- H: 220 V AC
- J: 240 V AC
- DC Power**
- S: 12 V DC
- R: 24 V DC
- V: 48 V DC
- P: 110 V DC

**[5] OPTIONS**

- Burnout**
- blank: Upscale burnout
- /BL: Downscale burnout
- /BN: No burnout

**GENERAL SPECIFICATIONS**

- Construction:** Plug-in
- Connection:** M3.5 screw terminals
- Housing material:** Flame-resistant resin (black)
- Isolation:** Input to output 1 to output 2 to power
- Setpoint adjustments:** 10-position rotary switches (front); 0 – 99 % independently; 1 % increments
- Linearization:** Standard
- Cold junction compensation:** CJC sensor attached to the input terminals
- Hysteresis (deadband):** 0.7 – 2.5 %
- Front LEDs:** Red lights turn on when the coils are energized.
- Power ON timer:** Relays de-energized for approx. 2 seconds after power is turned on.



## INPUT SPECIFICATIONS

**Minimum span:** 3 mV  
**Offset:** Max. 1.5 times span  
**Input resistance:** 30 kΩ min.  
**Burnout sensing:** 0.1 μA

**Minimum span (in °C)**  
**(PR):** min. span 370°C  
**K (CA):** min. span 75°C  
**E (CRC):** min. span 50°C  
**J (IC):** min. span 60°C  
**T (CC):** min. span 75°C  
**B (RH):** min. span 780°C  
**R:** min. span 360°C  
**S:** min. span 380°C  
**N:** min. span 110°C

**Minimum span (in °F)**  
**(PR):** min. span 670°F  
**K (CA):** min. span 140°F  
**E (CRC):** min. span 90°F  
**J (IC):** min. span 110°F  
**T (CC):** min. span 140°F  
**B (RH):** min. span 1410°F  
**R:** min. span 650°F  
**S:** min. span 690°F  
**N:** min. span 200°F

**Remark:** The described accuracy may be partially not satisfied when the temperature ranges below 0°C. Consult factory.

## OUTPUT SPECIFICATIONS

■ **Relay Contact:** 100 V AC @ 1 A (cos φ = 1)  
 120 V AC @ 1 A (cos φ = 1)  
 240 V AC @ 0.5 A (cos φ = 1)  
 30 V DC @ 1 A (resistive load)  
**Maximum switching voltage:** 380 V AC or 125 V DC  
**Maximum switching power:** 120 VA or 30 W  
**Minimum load:** 5 V DC @ 10 mA  
**Mechanical life:** 5 x 10<sup>7</sup> cycles  
 For maximum relay life with inductive loads, external protection is recommended.

## Alarm Trip Operation Terminal No. in parentheses

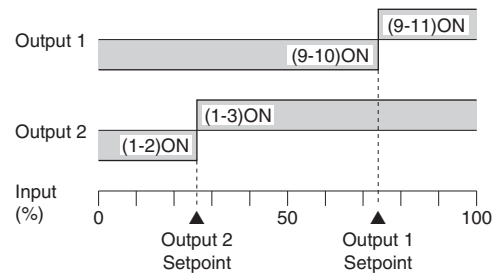

## Trip Operation in Power Failure

- **Output Code: 1 & 4:** Terminals 1 – 2, 9 – 10 turn ON
- **Output Code: 2 & 3:** Terminals 1 – 3, 9 – 11 turn ON

## INSTALLATION

### Power input

- **AC:** Operational voltage range: rating ±10 %, 50/60 ±2 Hz, approx. 2 VA
- **DC:** Operational voltage range: rating ±10 %, or 85 – 150 V for 110 V rating (ripple 10 % p-p max.)  
 Approx. 2 W (80 mA at 24 V)

**Operating temperature:** -5 to +60°C (23 to 140°F)

**Operating humidity:** 30 to 90 %RH (non-condensing)

**Mounting:** Surface or DIN rail

**Weight:** 370 g (0.82 lbs)

## PERFORMANCE in percentage of span

**Setpoint accuracy:** ±0.8 % (at over 400°C or 750°F for R, S and PR; over 770°C or 1420°F for B)

**Trip point repeatability:** ±0.05 %

(at over 400°C or 750°F for R, S and PR; over 770°C or 1420°F for B)

**Cold junction compensation error**

(at 20°C ±10°C or 68°F ±18°F)

**K, E, J, T & N:** ±0.5°C or ±0.9°F

**S, R & PR:** ±1°C or ±1.8°F

**Temp. coefficient:** ±0.015 %/°C (±0.008 %/°F)

(at over 400°C or 750°F for R, S and PR; over 770°C or 1420°F for B)

**Response time:** Approx. 0.5 sec. (0 – 100 % at 90 % setpoint)

**Burnout response:** ≤ 10 sec.

**Line voltage effect:** ±0.1 % over voltage range

**Insulation resistance:** ≥ 100 MΩ with 500 V DC

**Dielectric strength:** 2000 V AC @1 minute (input to output 1 to output 2 to power to ground)



## EXTERNAL VIEW

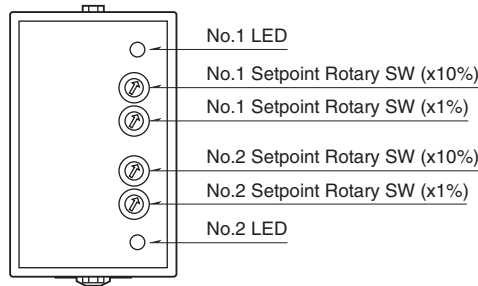

## DIMENSIONS unit: mm (inch)

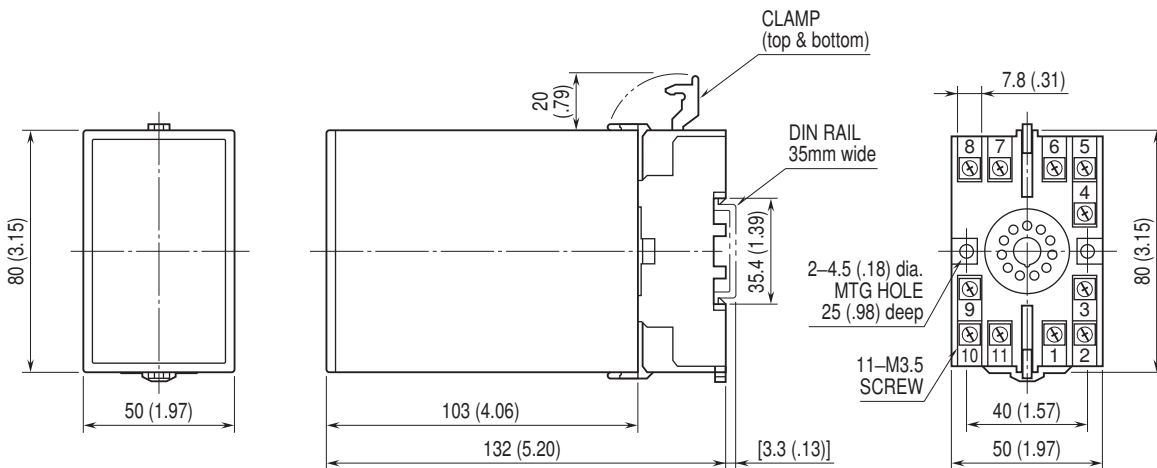

• When mounting, no extra space is needed between units.

## TERMINAL ASSIGNMENTS unit: mm (inch)

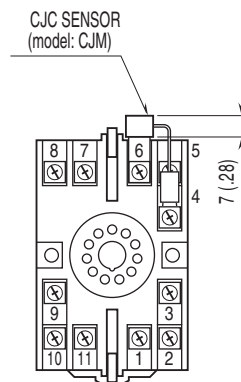

## SCHEMATIC CIRCUITRY & CONNECTION DIAGRAM

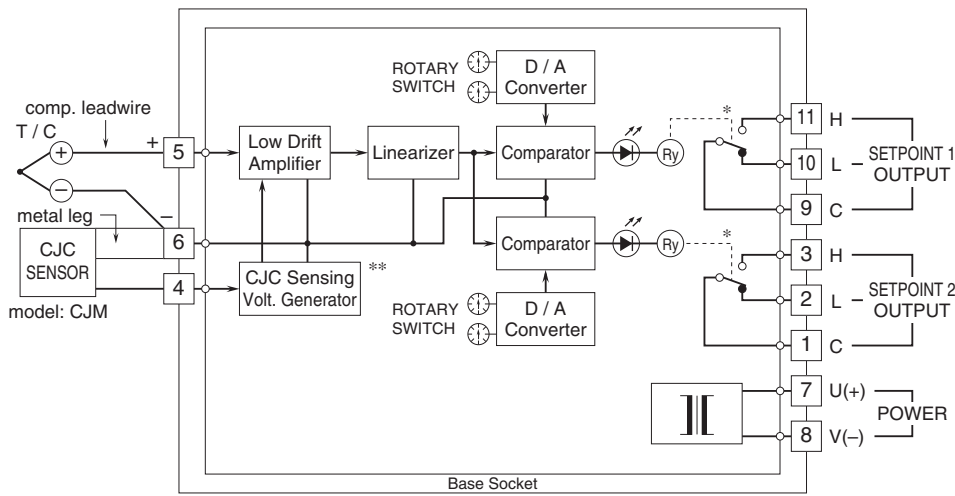

\* Relay status for output codes "1" & "4", at power OFF.  
 \*\*Deleted with B thermocouple

### ■ Relay Protection

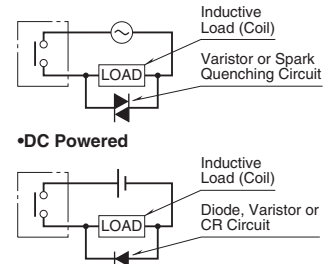

Specifications are subject to change without notice.