

Limit Alarms (with DC output) AE-UNIT

CT ALARM

Functions & Features

- Providing SPDT relay outputs at preset AC current levels from a CT
- True RMS sensing
- Dual (Hi/Lo) trip
- Additional isolated DC output proportional to the input
- CT Protector provided for open-circuit protection
- Energized or de-energized coil at a tripped condition selectable
- Thumbwheel switch adjustments
- Relays can be powered 110 V DC

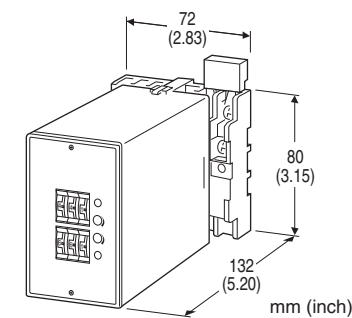

MODEL: AECT-[1][2][3][4][5][6]-[7]

ORDERING INFORMATION

- Code number: AECT-[1][2][3][4][5][6]-[7]
- Specify a code from below for each [1] through [7]. (e.g. AECT-1A1111-D)
- Special DC output range (For codes Z & 0)

[1] INPUT

Current

- 1: 0 - 1 A AC
- 5: 0 - 5 A AC

[2] DC OUTPUT

N: None

Current

- A: 4 - 20 mA DC (Load resistance 350 Ω max.)
- B: 2 - 10 mA DC (Load resistance 700 Ω max.)
- C: 1 - 5 mA DC (Load resistance 1400 Ω max.)
- D: 0 - 20 mA DC (Load resistance 350 Ω max.)
- E: 0 - 16 mA DC (Load resistance 430 Ω max.)
- F: 0 - 10 mA DC (Load resistance 700 Ω max.)
- G: 0 - 1 mA DC (Load resistance 7000 Ω max.)
- Z: Specify current (See OUTPUT SPECIFICATIONS)

Voltage

- 1: 0 - 10 mV DC (Load resistance 10 kΩ min.)
- 2: 0 - 100 mV DC (Load resistance 100 kΩ min.)
- 3: 0 - 1 V DC (Load resistance 1000 Ω min.)
- 4: 0 - 10 V DC (Load resistance 10 kΩ min.)
- 5: 0 - 5 V DC (Load resistance 5000 Ω min.)
- 6: 1 - 5 V DC (Load resistance 5000 Ω min.)
- 4W: -10 - +10 V DC (Load resistance 10 kΩ min.)
- 5W: -5 - +5 V DC (Load resistance 5000 Ω min.)
- 0: Specify voltage (See OUTPUT SPECIFICATIONS)

[3] SETPOINT 1 OUTPUT

- 1: Hi (coil energized at alarm)
- 2: Hi (coil de-energized at alarm)
- 3: Lo (coil energized at alarm)
- 4: Lo (coil de-energized at alarm)

[4] SETPOINT 2 OUTPUT

- 1: Hi (coil energized at alarm)
- 2: Hi (coil de-energized at alarm)
- 3: Lo (coil energized at alarm)
- 4: Lo (coil de-energized at alarm)

[5] ON DELAY TIME

- 0: 0.5 seconds
- 1: 1 second
- 2: 2 seconds
- 3: 3 seconds
- 4: 4 seconds

[6] POWER ON DELAY TIME

- 1: 1 second
- 2: 2 seconds
- 3: 3 seconds
- 4: 4 seconds
- 5: 5 seconds

[7] POWER INPUT

AC Power

- B: 100 V AC
- C: 110 V AC
- D: 115 V AC
- F: 120 V AC
- G: 200 V AC
- H: 220 V AC
- J: 240 V AC

DC Power

- S: 12 V DC
- R: 24 V DC
- V: 48 V DC
- P: 110 V DC



GENERAL SPECIFICATIONS

Construction: Plug-in
Connection: M3.5 screw terminals
Housing material: Flame-resistant resin (black)
Isolation: Input to DC output to alarm output 1 to alarm output 2 to power
Input waveform: Up to 15 % of 3rd harmonic content
Zero adjustment: -5 to +5 % (front)
Span adjustment: 95 to 105 % (front)
Setpoint adjustments: Thumbwheel switches (front); 0 - 99 % independently; 1 % increments
Hysteresis (deadband) adjustments: Thumbwheel switches (front); 0.5, 1 - 9 % independently; 1 % increments (SW position 0 = 0.5); [Lo SP + Hysteresis] ≤ 102
Front LEDs: Red lights turn on when the coils are energized.

INPUT SPECIFICATIONS

Frequency: 50 or 60 Hz
Input burden: 0.5 VA maximum
Overload capacity: 500 % of rating for 5 sec., 120 % continuous
Operational range: 0 - 100 % of rating

OUTPUT SPECIFICATIONS

■ **DC Output**
 • **DC Current:** 0 - 20 mA DC
Minimum span: 1 mA
Offset: Max. 1.5 times span
Load resistance: Output drive 7 V maximum
 • **DC Voltage:** -10 - +12 V DC
Minimum span: 5 mV
Offset: Max. 1.5 times span
Load resistance: Output drive 1 mA maximum; at ≥ 0.5 V
 ■ **Alarm Output:** Relay contact
 100 V AC @ 1 A (cos ϕ = 1)
 120 V AC @ 1 A (cos ϕ = 1)
 240 V AC @ 0.5 A (cos ϕ = 1)
 30 V DC @ 1 A (resistive load)
Maximum switching voltage: 380 V AC or 125 V DC
Maximum switching power: 120 VA or 30 W
Minimum load: 5 V DC @ 10 mA
Mechanical life: 5 x 10⁷ cycles
 For maximum relay life with inductive loads, external protection is recommended.

Alarm Trip Operation Terminal No. in parentheses

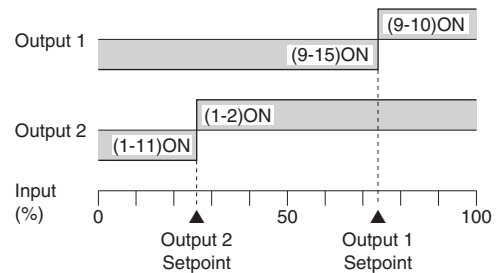

Trip Operation in Power Failure

- **Output Code: 1 & 4:** Terminals 1 - 11, 9 - 15 turn ON
- **Output Code: 2 & 3:** Terminals 1 - 2, 9 - 10 turn ON

INSTALLATION

Power input

- **AC:** Operational voltage range: rating ± 10 %, 50/60 ± 2 Hz, approx. 3 VA
- **DC:** Operational voltage range: rating ± 10 %, or 85 - 150 V for 110 V rating (ripple 10 % p-p max.). Approx. 2 W (80 mA at 24 V)
- Operating temperature:** -5 to +55°C (23 to 131°F)
- Operating humidity:** 30 to 90 %RH (non-condensing)
- Mounting:** Surface or DIN rail
- Weight:** 450 g (0.99 lbs)

PERFORMANCE in percentage of span

- **DC output**
Accuracy: ± 0.3 %
Response time: ≤ 0.7 secs. (0 - 90 %)
- **Alarm output**
Setpoint accuracy: ± 0.8 %
Hysteresis (Deadband) setpoint accuracy: ± 0.3 %
ON delay time accuracy: Rating ± 20 % or 0.7 sec., whichever is greater.
Power ON delay time accuracy: Rating ± 30 %
Trip point repeatability: ± 0.05 %
Temp. coefficient: ± 0.015 %/°C (± 0.008 %/°F)
Line voltage effect: ± 0.1 % over voltage range
Insulation resistance: ≥ 100 M Ω with 500 V DC
Dielectric strength: 2000 V AC @ 1 minute
 (input to DC output to alarm output 1 to alarm output 2 to power to ground)



EXTERNAL VIEW

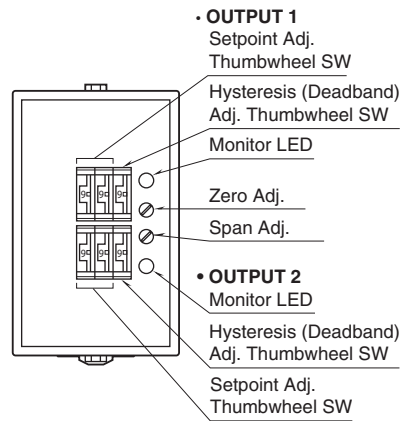

DIMENSIONS unit: mm (inch)

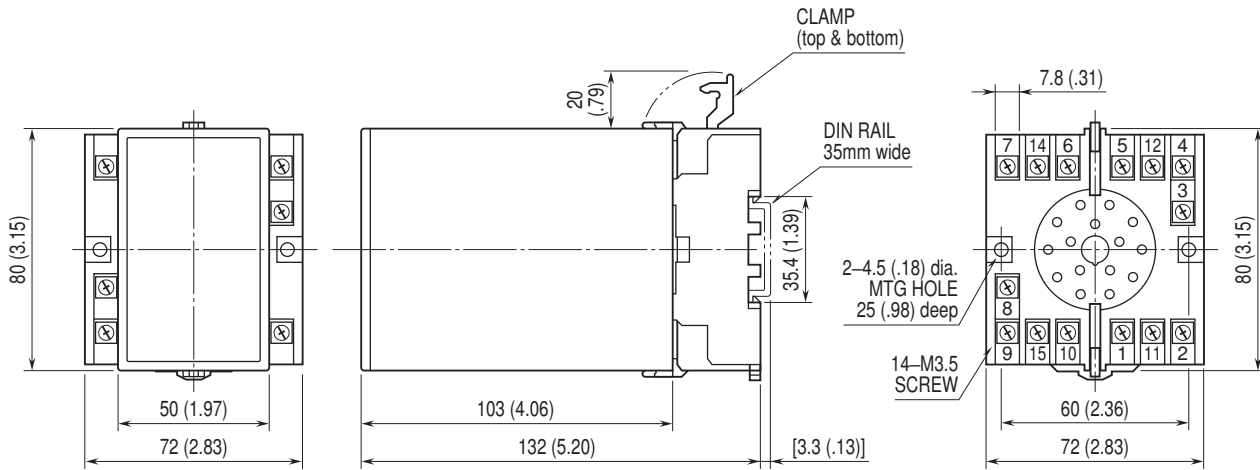

• When mounting, no extra space is needed between units.

TERMINAL ASSIGNMENTS unit: mm (inch)

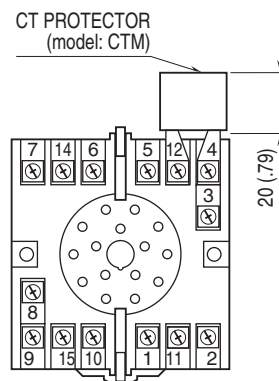

SCHEMATIC CIRCUITRY & CONNECTION DIAGRAM

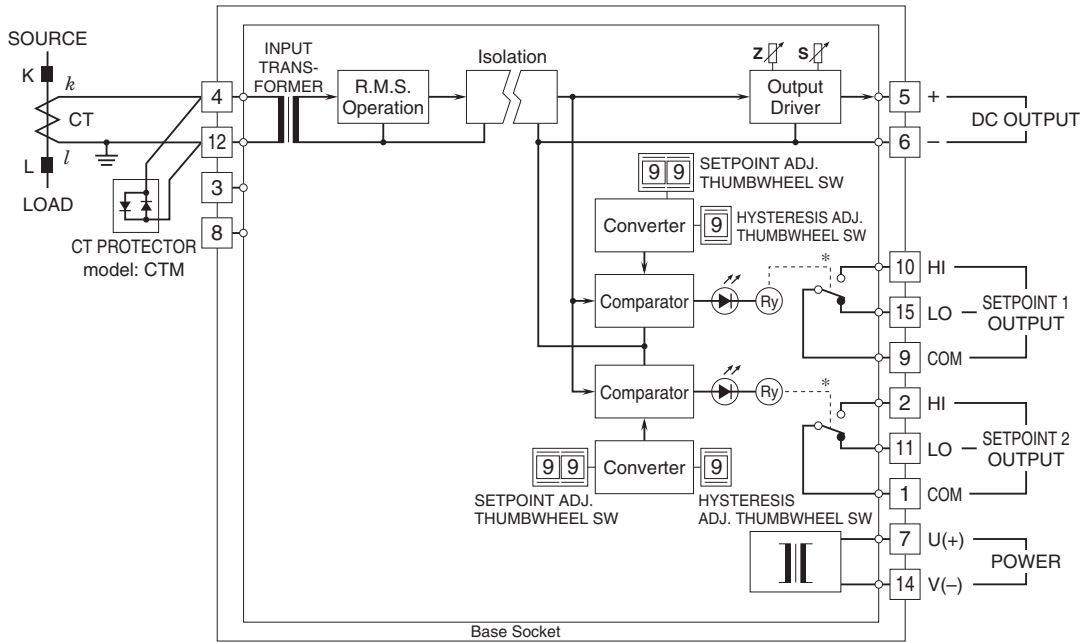

*Relay status for output codes "1" & "4", at power OFF.

■ Relay Protection

•AC Powered

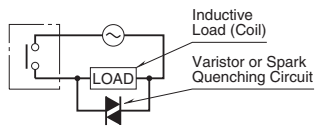

•DC Powered

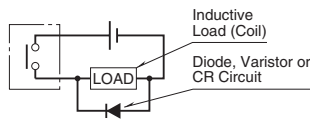

Specifications are subject to change without notice.