

## Final Control Elements

### ANALOG BACKUP STATION

(with bargraph/digital indicator)

#### Functions & Features

- Holds and manipulates control signals in case of computer or DCS failure
- Bargraph indicator
- Digital display indicating PV/CAS/MV selectable
- External contact closure to switch operation modes
- MV outputs CAS input signal at power down (for /T option)

#### Typical Applications

- Computer and DCS backup applications
- Used as manual-auto controller

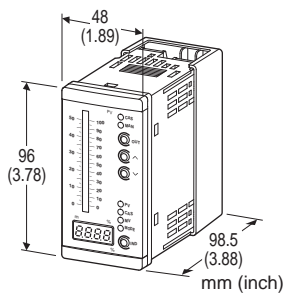

### MODEL: ABF3-[1][2][3]-[4][5]

#### ORDERING INFORMATION

- Code number: ABF3-[1][2][3]-[4][5]  
Specify a code from below for each [1] through [5].  
(e.g. ABF3-AAA-M2/C)
- Scale (Refer to 'SCALE PLATE' section for details on the scale.)

#### [1] PV INPUT

##### Current

- A: 4 - 20 mA DC (Input resistance 25  $\Omega$ )
- D: 0 - 20 mA DC (Input resistance 25  $\Omega$ )

##### Voltage

- 4: 0 - 10 V DC (Input resistance 1 M $\Omega$  min.)
- 5: 0 - 5 V DC (Input resistance 1 M $\Omega$  min.)
- 6: 1 - 5 V DC (Input resistance 1 M $\Omega$  min.)
- 4W: -10 - +10 V DC (Input resistance 1 M $\Omega$  min.)
- 5W: -5 - +5 V DC (Input resistance 1 M $\Omega$  min.)

#### [2] CAS INPUT

##### Current

- A: 4 - 20 mA DC (Input resistance 25  $\Omega$ )
- For /T option, maximum input resistance 80  $\Omega$

- D: 0 - 20 mA DC (Input resistance 25  $\Omega$ )

##### Voltage

- 4: 0 - 10 V DC (Input resistance 1 M $\Omega$  min.)
- 5: 0 - 5 V DC (Input resistance 1 M $\Omega$  min.)
- 6: 1 - 5 V DC (Input resistance 1 M $\Omega$  min.)
- 4W: -10 - +10 V DC (Input resistance 1 M $\Omega$  min.)
- 5W: -5 - +5 V DC (Input resistance 1 M $\Omega$  min.)

#### [3] MV OUTPUT

##### Current

- A: 4 - 20 mA DC (Load resistance 750  $\Omega$  max.)  
(For /T option, the load resistance is 25  $\Omega$  less than the CAS input equipment's load resistance.)
- D: 0 - 20 mA DC (Load resistance 750  $\Omega$  max.)

##### Voltage

- 4: 0 - 10 V DC (Load resistance 10 k $\Omega$  min.)
- 5: 0 - 5 V DC (Load resistance 5000  $\Omega$  min.)
- 6: 1 - 5 V DC (Load resistance 5000  $\Omega$  min.)
- 5W: -5 - +5 V DC (Load resistance 5000  $\Omega$  min.)

#### [4] POWER INPUT

##### AC Power

- M2: 100 - 240 V AC (Operational voltage range 85 - 264 V, 50/60 Hz)

##### DC Power

- R: 24 V DC  
(Operational voltage range 24 V  $\pm$ 10 %, ripple 10 %p-p max.)

#### [5] OPTIONS (multiple selections)

##### Bargraph Indicator

- blank: PV input
- /C: CAS input
- /M: MV output

##### MV Output at Power Down

- blank: Output off
- /T: CAS input  
(Applicable CAS input and MV output: 4 - 20 mA DC)

#### SPARE PARTS

- Scale plate

#### GENERAL SPECIFICATIONS

- Construction:** Panel flush mounting
- Degree of protection:** IP65; applicable to the front panel for single unit mounted according to the specified panel cutout
- Connection:** M3 screw terminals (torque 0.6 N·m)
- Screw terminal:** Nickel-plated steel
- Housing material:** Flame-resistant resin (gray)
- **BUTTONS**
- Digital display selector (IND):** Switches between PV input, CAS input, MV output; Manual operation ramp rate,



Retroactive time period, or Transition amp rate

**Manual output switching:** CAS (cascade) - MAN (manual) selector ('OUT'); the mode selected before power OFF is recovered when the power is turned on.

**Remote output switching:** External contact closure switches the ABF3 to MAN mode when the CAS-MAN selector is at CAS position; Not switched with MAN position.

## FUNCTIONS

**Manual status contact:** Turns on when manual operation is available

**Manual operation ramp rate:** 15 sec./100 %. (Add 0.3 sec. for the total time required to go from 0 % to 100 %.)

Adjustable up to 30 sec. in 1 sec. increments with front control buttons

**Retroactive time period at switching CAS to MAN:** 0 sec. plus response time. Adjustable up to 30 sec. in 1 sec. increments with front control buttons

When the loop has been turned to MAN control, the MV output goes back by the preset time period and holds the output.

**Ramp rate at switching MAN to CAS:** 1 sec./100 %.

Adjustable up to 30 sec. in 1 sec. increments with front control buttons

If the CAS control value at the moment of switching from MAN to CAS mode is deviated from the MV output value in MAN control, the ABF3 adjusts the difference gradually in the preset ramp rate.

Receiving MAN command during transition ramp period, the ABF3 turns to MAN mode after transition ramp function is completed.

**Isolation:** PV input to CAS input to MV output to MAN status contact to remote output switching command to power (For /T option, non-isolated between CAS input and MV output)

**SCALE PLATE:** Flame resistant resin (replaceable at the front; white scale & characters on black base)

**Scale:** Max. 4 characters including decimal point and negative sign

- **Divisions:** Min. 21, max. 43.9
- **Engineering unit:** Max. 4 characters (Unit other than % also can be specified)

**BARGRAPH:** PV input, CAS input or MV output  
**LED:** 55 segments, red, 55.5 mm (2.19") long, 3.0 mm (.12") wide

**DIGITAL INDICATOR:** PV input, CAS input, MV output; setting values for Manual operation ramp rate, Retroactive time period, or Transition ramp rate

**LED:** 4 digits, red, 10 mm (.39") high, 24 mm (.94") wide

**Scaling:** -15.0 to +115.0 % fixed

## LEDs

**CAS output LED:** Red light turns on in CAS mode.

**MAN output LED:** Red light turns on in MAN mode.

**PV LED:** Red light turns on with PV indication.

Green light turns on while setting the manual operation ramp rate.

**CAS LED:** Red light turns on with CAS indication.

Green light turns on while setting the retroactive time period.

**MV LED:** Red light turns on with MV indication.

Green light turns on while setting the transition ramp rate.

**MODE LED:** Red light turns on with the version indication.

Green light turns on but Not Used.

EXTERNAL CONTACT	FRONT CAS-MAN SELECTOR	
	CAS	MAN
ON	MAN	MAN
OFF	CAS	MAN

## INPUT SPECIFICATIONS

**PV input, CAS input:** -15.0 to +115.0 %

**Remote Output Switching Command Sensing:** 5 V DC @ 5 mA

**ON/OFF level:**  $\geq 1 \text{ k}\Omega$  for OFF;  $\leq 100 \Omega$  for ON

## OUTPUT SPECIFICATIONS

**MV output:** -15.0 to +115.0 %, 0.1 % increments

**MV Conformance range:** 0 - 100 %

**Manual Status Contact Output**

**Rated load:** 120 V AC @ 1 A ( $\cos \phi = 1$ )

240 V AC @ 0.5 A ( $\cos \phi = 1$ )

30 V DC @ 1 A (resistive load)

Electrical life  $\geq 10^5$  cycles (rate 6 cycles/min.)

**Minimum load:** 5 V DC @ 24 mA (Approx. 120 mW)

**Mechanical life:**  $\geq 5 \times 10^6$  cycles (rate 180 cycles/min.)

## INSTALLATION

**Power consumption**

• **AC:**

Approx. 4 VA at 100 V (For /T option, approx. 5 VA)

Approx. 6 VA at 264 V (For /T option, approx. 7 VA)

• **DC:** Approx. 3.5 W

**Operating temperature:** -5 to +55°C (23 to 131°F)

**Operating humidity:** 30 to 90 %RH (non-condensing)

**Mounting:** Panel flush mounting

**Weight:** 300 g (0.66 lbs)

## PERFORMANCE in percentage of span

**Accuracy:** Input + output conversion accuracy

• **Input:**  $\pm 0.2$  % of input range

• **Output:**  $\pm 0.1$  % of output range

**Display accuracy:**

• **Bargraph:**  $\pm 2$  %



- **Digital indicator:**  $\pm 0.3\%$  (including  $\pm 1$  digit)
- Temp. coefficient:**  $\pm 0.02\% / ^\circ\text{C}$  ( $\pm 0.01\% / ^\circ\text{F}$ )
- Manual output resolution:**  $0.1\%$
- Response time:**  $\leq 0.5$  sec. (0 - 90 %) with CAS input
- Output memory at power OFF:** E<sup>2</sup>PROM (non-volatile memory)
- Line voltage effect:**  $\pm 0.1\%$  over voltage range
- Insulation resistance:**  $\geq 100\text{ M}\Omega$  with 500 V DC
- Dielectric strength:** 1500 V AC @ 1 minute (PV input to CAS input to MV output to MAN status contact to remote output switching command input to power to ground)  
(For /T option, non-isolated between CAS input and MV output)

## SCALE PLATE

### ■ WHAT MUST BE SPECIFIED WHEN ORDERING

Please specify the bargraph scale range and engineering unit. Number of divisions, division line length, character font are determined by M-System.

### ■ TYPES OF DIVISIONS

Five (5) types of divisions are used depending upon the scale span, which determined by the following equation:

$$\text{Scale Span} = (\text{Max. range value} - \text{Min. range value}) \cdot 10^n$$

where n = integer (used to limit the calculated scale span to the minimum of 1.1, below 11.0.)

#### • Type 1: 1.1 Scale Span < 1.3

**Number of divisions:** 22 to 25.9

**Scale:** Starts at 0, increments in 0.02 / 0.2 / 2 / 20 / 200.

Min. and max. values are indicated.

4 digits including negative sign and decimal point.

**Division lines:** Long, Short, Medium, Short, Long  
(4 division lines repeating)

#### • Type 2: 1.3 Scale Span < 2.0

**Number of divisions:** 26 to 39.9

**Scale:** Starts at 0, increments in 0.03 / 0.3 / 3 / 30 / 300.

Min. and max. values are indicated.

4 digits including negative sign and decimal point.

**Division lines:** Long, Short, Medium, Short, Medium, Short, Long  
(6 divisions repeating)

Minimum Divisions	Maximum Divisions	Bipolar Scale
11 —	1.29 —	600 —
10 —	1.2 —	400 —
8 —	1.0 —	200 —
6 —	0.8 —	0 —
4 —	0.6 —	-200 —
2 —	0.4 —	-400 —
0 —	0 —	-600 —

Minimum Divisions	Maximum Divisions	Bipolar Scale
130 —	1.99 —	0.8 —
120 —	1.8 —	0.6 —
90 —	1.5 —	0.3 —
60 —	1.2 —	0.0 —
30 —	0.9 —	-0.3 —
0 —	0.6 —	-0.6 —
	0.3 —	-0.8 —
	0.0 —	



• **Type 3:  $2.0 \leq \text{Scale Span} < 2.6$**

**Number of divisions:** 32 to 41.9

**Scale:** Starts at 0, increments in 0.05 / 0.5 / 5 / 50 / 500.

Min. and max. values are indicated.

4 digits including negative sign and decimal point.

**Division lines:** Long, Short, Medium, Short, Medium, Short, Medium, Short, Long (8 divisions repeating)

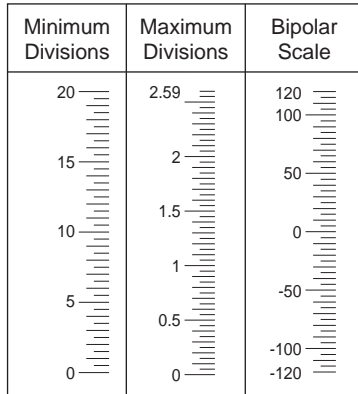

• **Type 5:  $5.5 \leq \text{Scale Span} < 11.0$**

**Number of divisions:** 22 to 43.9

**Scale:** Starts at 0, increments in 0.01 / 0.1 / 1 / 10 / 100 / 1000.

Min. and max. values are indicated.

4 digits including negative sign and decimal point.

**Division lines:** Long, Medium, Medium, Medium, Long (5 divisions repeating)

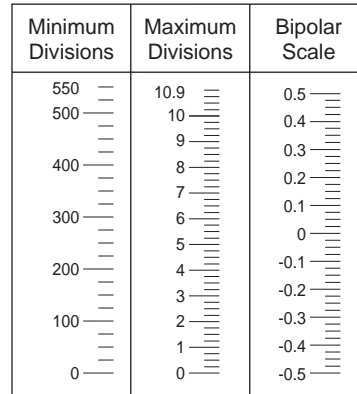

• **Type 4:  $2.6 \leq \text{Scale Span} < 5.5$**

**Number of divisions:** 26 to 43.9

**Scale:** Starts at 0, increments in 0.05 / 0.5 / 5 / 50 / 500.

Min. and max. values are indicated.

4 digits including negative sign and decimal point.

**Division lines:** Long, Medium, Medium, Medium, Long (4 divisions repeating)

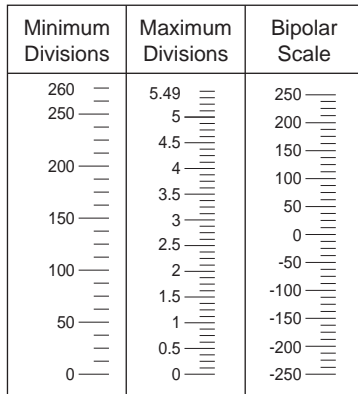

## EXTERNAL VIEW

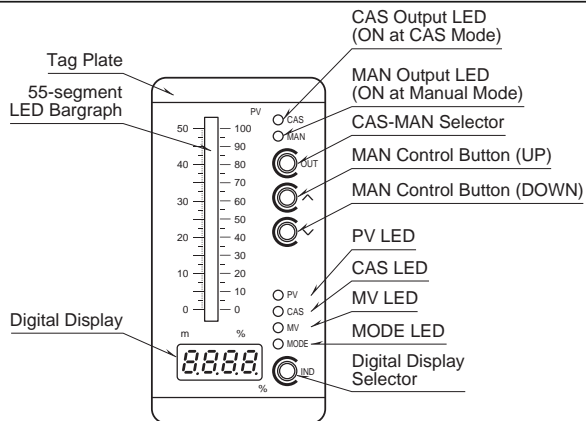

## EXTERNAL DIMENSIONS & TERMINAL ASSIGNMENTS unit: mm (inch)

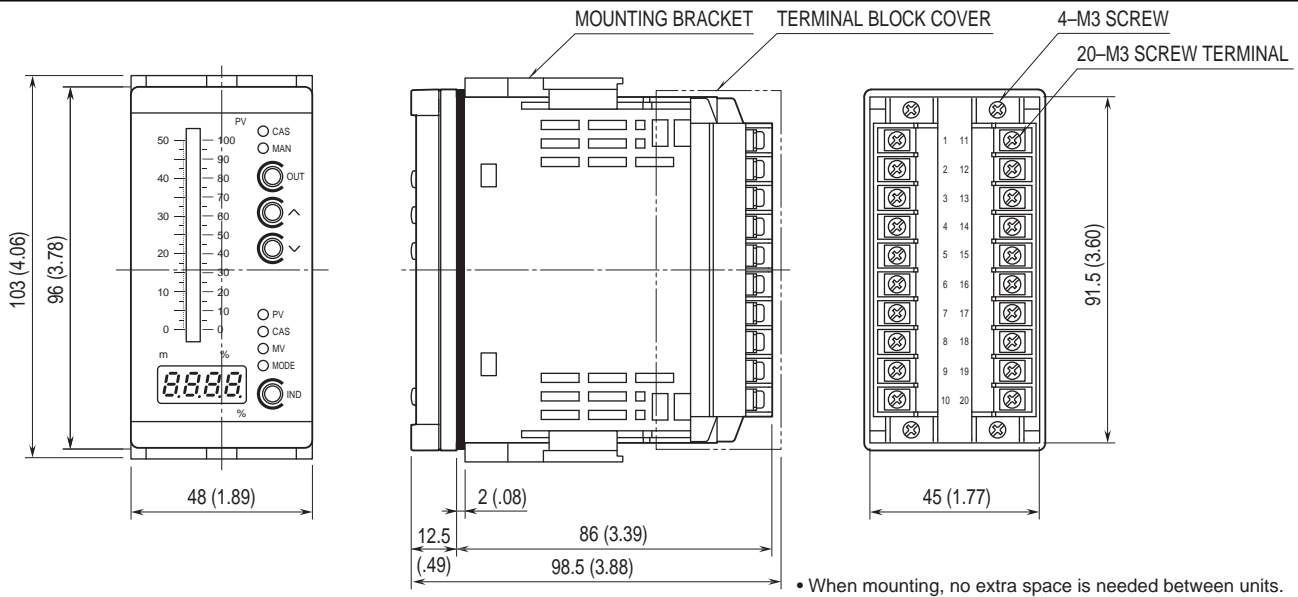

## PANEL CUTOUT unit: mm (inch)

• Single Mounting (ingress protection)

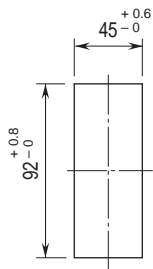

Panel thickness: 1.6 – 8.0 mm

• Clustered Mounting (no ingress protection)

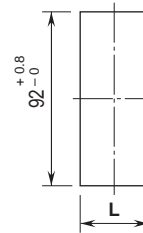

Panel thickness: 1.6 – 8.0 mm

$$L = (45.5 + 48 \times (N - 1))_{\pm 0.1}$$

(N : number of units)

Observe at the minimum of 3 cm above and below the units for heat dissipation.

**SCHEMATIC CIRCUITRY & CONNECTION DIAGRAM**

• 'MV output at power down' option with 'output off'

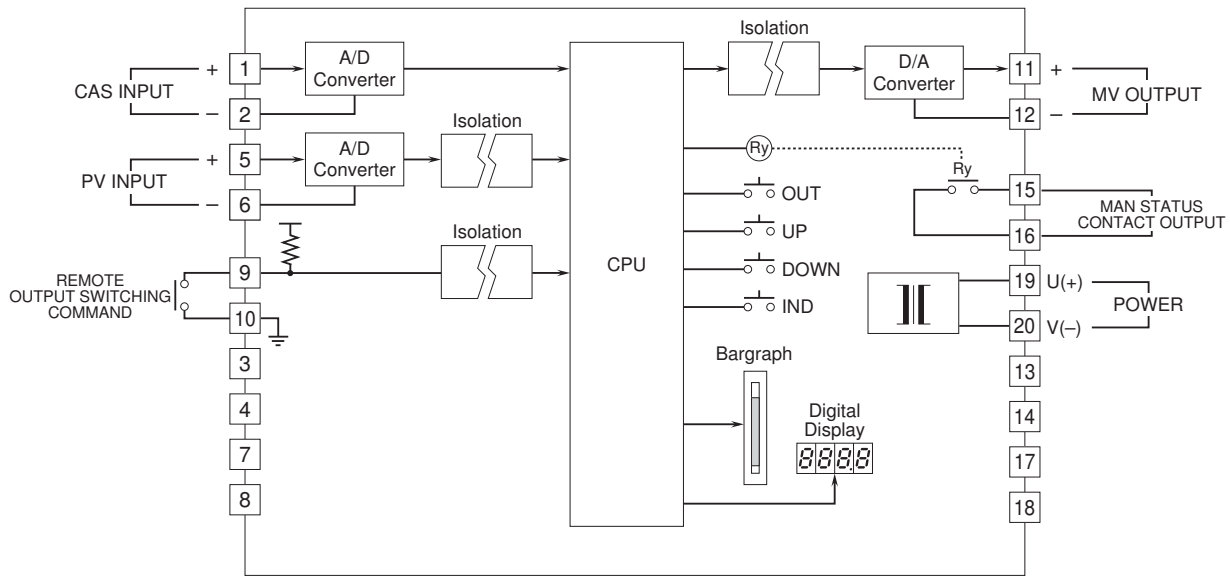

• 'MV output at power down' option with 'CAS input'

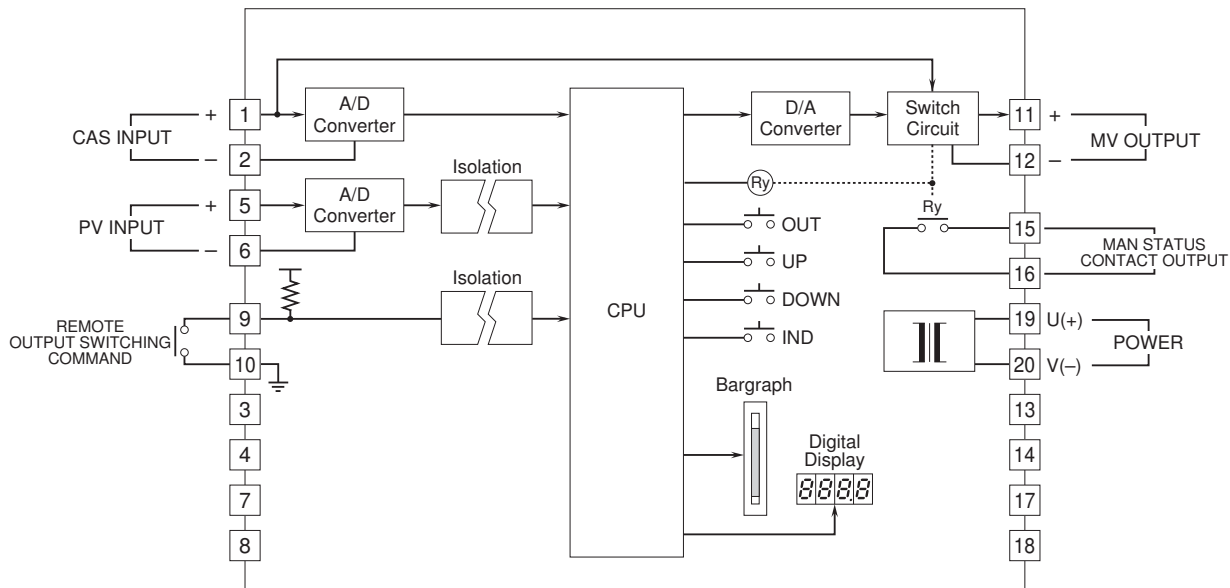

Specifications are subject to change without notice.

