

Plug-in Signal Conditioners M-UNIT

ANALOG BACKUP STATION

Functions & Features

- Holding and manipulating control signals in case of computer or DCS failure
- Ramp rate adjustable
- High-density mounting

Typical Applications

- Computer and DCS backup applications
- Used as manual-auto controller

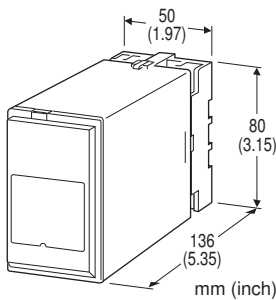

MODEL: AB2-[1][2]-[3][4]

ORDERING INFORMATION

- Code number: AB2-[1][2]-[3][4]

Specify a code from below for each [1] through [4].
(e.g. AB2-1A-B/Q)

- Special input and output ranges (For codes Z & 0)
- Specify the specification for option code /Q
(e.g. /C01/S01)

Use Ordering Information Sheet (NO. ESU-2635) when presetting of the upper/lower output limit or the ramp rate range for MAN mode is necessary.

Factory standard setting will be used if not otherwise specified.

Factory standard settings are as follows.

Lower output limit: -15.0%

Upper output limit: 115.0%

Minimum response time* (MAN mode): 5s

Maximum response time* (MAN mode): 30s

* Minimum response time < Maximum response time

[1] INPUT

Current

- A: 4 - 20 mA DC (Input resistance 250 Ω)
- A1: 4 - 20 mA DC (Input resistance 50 Ω)
- B: 2 - 10 mA DC (Input resistance 500 Ω)
- C: 1 - 5 mA DC (Input resistance 1000 Ω)

- D: 0 - 20 mA DC (Input resistance 50 Ω)
- E: 0 - 16 mA DC (Input resistance 62.5 Ω)
- F: 0 - 10 mA DC (Input resistance 100 Ω)
- G: 0 - 1 mA DC (Input resistance 1000 Ω)
- H: 10 - 50 mA DC (Input resistance 100 Ω)
- Z: Specify current (See INPUT SPECIFICATIONS)

Voltage

- 1: 0 - 10 mV DC (Input resistance 10 kΩ min.)
- 2: 0 - 100 mV DC (Input resistance 100 kΩ min.)
- 3: 0 - 1 V DC (Input resistance 1 MΩ min.)
- 4: 0 - 10 V DC (Input resistance 1 MΩ min.)
- 5: 0 - 5 V DC (Input resistance 1 MΩ min.)
- 6: 1 - 5 V DC (Input resistance 1 MΩ min.)
- 4W: -10 - +10 V DC (Input resistance 1 MΩ min.)
- 0: Specify voltage (See INPUT SPECIFICATIONS)

[2] OUTPUT

Current

- A: 4 - 20 mA DC (Load resistance 750 Ω max.)
- B: 2 - 10 mA DC (Load resistance 1500 Ω max.)
- C: 1 - 5 mA DC (Load resistance 3000 Ω max.)
- D: 0 - 20 mA DC (Load resistance 750 Ω max.)
- E: 0 - 16 mA DC (Load resistance 900 Ω max.)
- F: 0 - 10 mA DC (Load resistance 1500 Ω max.)
- G: 0 - 1 mA DC (Load resistance 15 kΩ max.)
- Z: Specify current (See OUTPUT SPECIFICATIONS)

Voltage

- 1: 0 - 10 mV DC (Load resistance 10 kΩ min.)
- 2: 0 - 100 mV DC (Load resistance 100 kΩ min.)
- 3: 0 - 1 V DC (Load resistance 100 Ω min.)
- 4: 0 - 10 V DC (Load resistance 1000 Ω min.)
- 5: 0 - 5 V DC (Load resistance 500 Ω min.)
- 6: 1 - 5 V DC (Load resistance 500 Ω min.)
- 4W: -10 - +10 V DC (Load resistance 2000 Ω min.)
- 0: Specify voltage (See OUTPUT SPECIFICATIONS)

[3] POWER INPUT

AC Power

- B: 100 V AC
- C: 110 V AC
- D: 115 V AC
- F: 120 V AC
- G: 200 V AC
- H: 220 V AC
- J: 240 V AC

DC Power

- S: 12 V DC
- R: 24 V DC



[4] OPTIONS

blank: none

/Q: With options (specify the specification)

SPECIFICATIONS OF OPTION: Q**COATING (For the detail, refer to M-System's web site.)**

/C01: Silicone coating

/C02: Polyurethane coating

/C03: Rubber coating

TERMINAL SCREW MATERIAL

/S01: Stainless steel

RELATED PRODUCTS

• Soft-Terminal (model: ST/STL)

GENERAL SPECIFICATIONS**Construction:** Plug-in**Connection:** M3.5 screw terminals**Screw terminal:** Chromated steel (standard) or stainless steel**Housing material:** Flame-resistant resin (black)**Isolation:** Input to output to power**Overrange output:** Approx. -15 to +115 % (Factory default)**Lower output limit available range:** -15.0 to 0.0 %**Upper output limit available range:** 100.0 to 115.0 %**Ramp rate adjustment (MAN mode only):** Approx. 1 - 999 sec. (front)

(Factory default: Approx. 5 - 30s)

Minimum response time* available range (MAN mode):

3 - 990s

Maximum response time* available range (MAN mode):

3 - 990s

* Minimum response time < Maximum response time

Zero adjustment: -5 to +5 % (front)**Span adjustment:** 95 to 105 % (front)**INPUT SPECIFICATIONS**■ **DC Current (from the computer):** Shunt resistor attached to input terminals (0.5 W)■ **DC Voltage (from the computer):** -300 - +300 V DC**Input resistance**Span 10 - 100 mV: Input resistance \geq 10 k Ω Span 0.1 - 1 V: Input resistance \geq 100 k Ω Span \geq 1 V: Input resistance \geq 1 M Ω **Minimum span:** 10 mV**Offset:** Max. 1.5 times span■ **Contact Input:** TTL level (5V-CMOS level) or open collector/dry contact (saturation voltage \leq 1 V, sink current 0.5 mA)

• Stop signal from the computer

ON: The AB2 tracks the computer input.**OFF:** The AB2 holds the value just before the OFF signal.• **Soft-terminal input in manual mode****UP:** The output increases with UP signal ON.**DOWN:** The output decreases with DOWN signal ON.**OUTPUT SPECIFICATIONS**■ **DC Current:** 0 - 20 mA DC**Minimum span:** 1 mA**Offset:** Max. 1.5 times span**Load resistance:** Output drive 15 V max.■ **DC Voltage:** -10 - +12 V DC**Minimum span:** 5 mV**Offset:** Max. 1.5 times span**Load resistance:** Output drive 10 mA max.; 5 mA for negative voltage output; at \geq 0.5 V**INSTALLATION****Power input**• **AC:** Rating \pm 10 %, 50/60 \pm 2 Hz,

approx. 5 VA at 100 V

approx. 7 VA at 200 V

approx. 10 VA at 240 V

• **DC:** Rating \pm 10 % (ripple 10 %p-p max.) approx. 3.5 W (150 mA at 24 V)**Operating temperature:** -5 to +55°C (23 to 131°F)**Operating humidity:** 30 to 90 %RH (non-condensing)**Mounting:** Surface or DIN rail**Weight:** 450 g (0.99 lb)**PERFORMANCE in percentage of span****Accuracy:** \pm 0.15 %**AUTO to MAN switching accuracy:** \pm 0.5 %**Temp. coefficient:** \pm 0.02 %/°C (\pm 0.01 %/°F)**Response time:** \leq 0.8 sec. in AUTO (0 - 90 %)

Approx. 3 - 990 sec. variable in MAN (0 - 100 %)

(default setting: Approx. 5 - 30 sec.)

The output tracks the computer input in AUTO response time during the transition from MAN to AUTO.

Output memory at power failure: The output value is stored in memory.**Line voltage effect:** \pm 0.1 % over voltage range**Insulation resistance:** \geq 100 M Ω with 500 V DC**Dielectric strength:** 1000 V AC @1 minute

(input to output to power)

2000 V AC @1 minute

(input or output or power to ground)



DIMENSIONS unit: mm (inch)

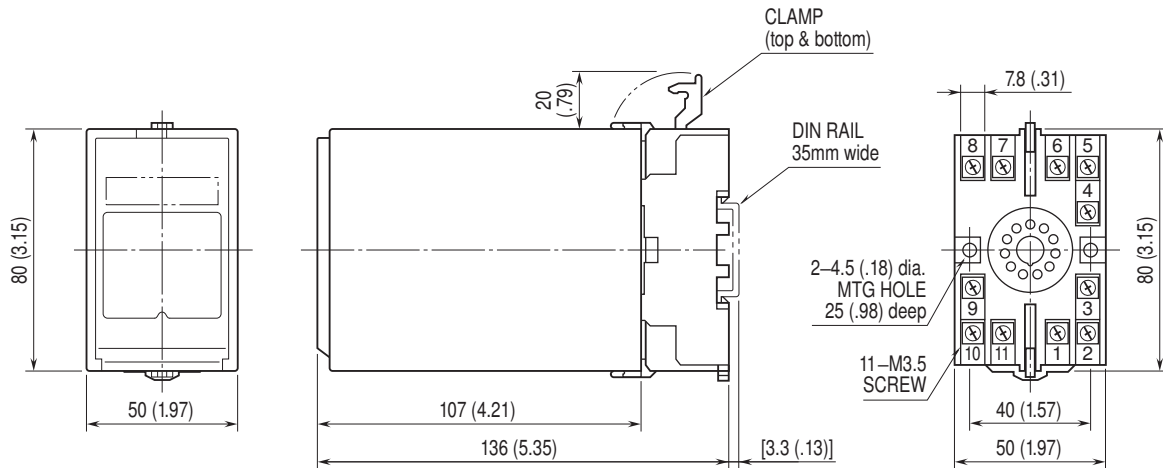

• When mounting, no extra space is needed between units.

TERMINAL ASSIGNMENTS unit: mm (inch)

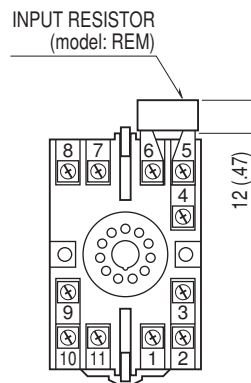

Input shunt resistor attached for current input.

SCHEMATIC CIRCUITRY & CONNECTION DIAGRAM

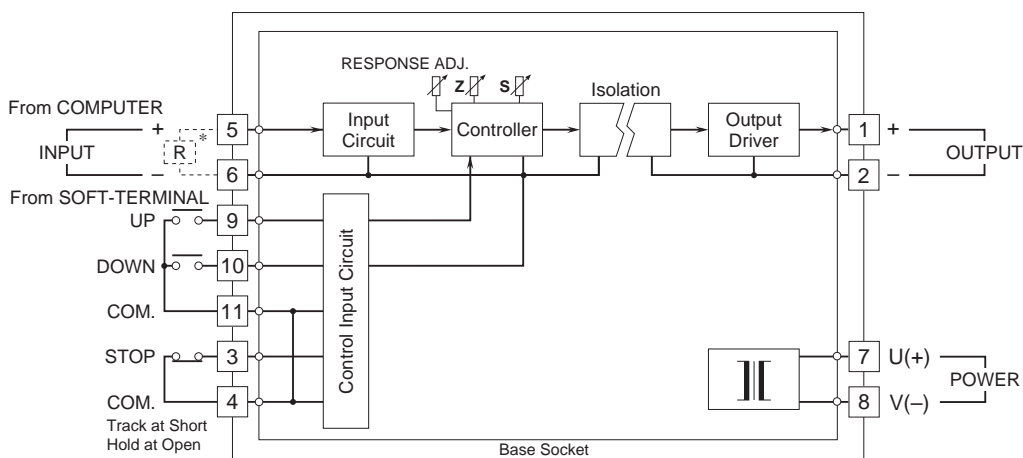

CONNECTION DIAGRAM

■ **AB2 Used Independently**

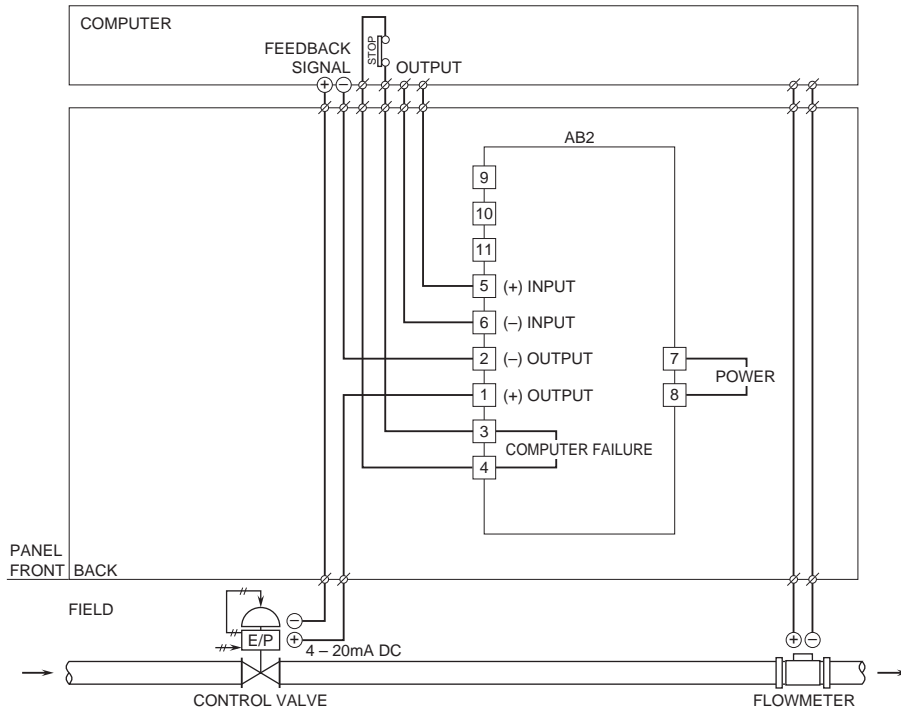

■ **AB2 Used in Combination with ST/STL**

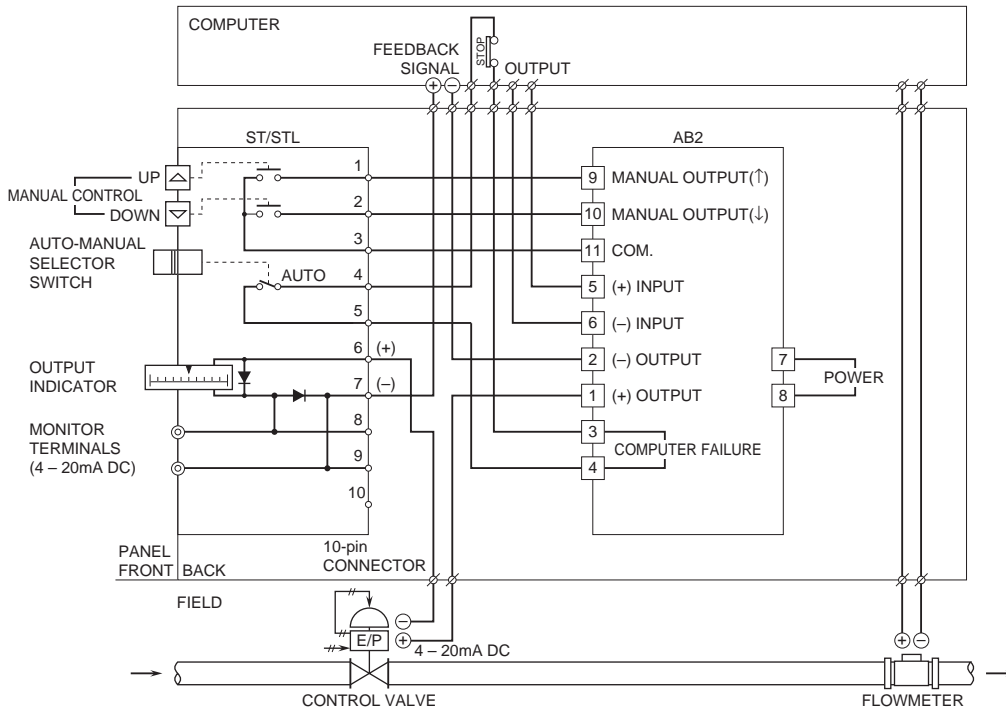

OPERATION

• AB2 Used Independently

In normal operating mode, the AB2 responds proportionally to its input (the computer output) in the response time of less than 0.8 seconds.

If the computer fails, this will be detected as a "STOP" command and output will be held at the value prior to the breakdown. You can increase the output signal by closing across the terminals 9 - 11, and decrease it by closing 10 - 11. The output responds in the preset ramp rate.

• AB2 Used in Combination with ST/STL

In normal operating mode, the AB2 responds proportionally to its input (the computer output) in the response time of less than 0.8 seconds.

If the computer fails, the "STOP" command will override computer output and put the unit in the manual operation mode by the ST/STL. Using the top-mounted UP-DOWN buttons, output can be increased or decreased in the preset ramp rate. Output signal value can be read on the top-mounted indicator. For more precise control, use the monitor terminals.

Also the computer input can be overridden with the AUTO-MANUAL selector on the Soft-Terminal.

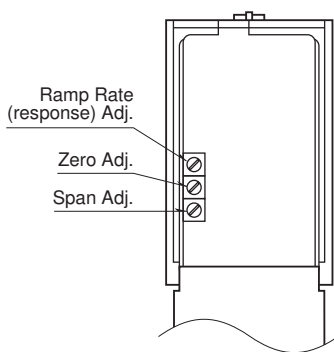

COMMAND		TERM.	SIGNAL STATUS
Computer	DC Signal	5 - 6	↑ ↓ ↑ ↓
	STOP	3 - 4	1 1 0 0 0 0 0
ST/STL	UP	9 - 11	- - - - 1 0 0 1
	DOWN	10 - 11	- - - - 0 1 0 1
Output of the AB2		1 - 2	↑ ↓ H H ↑ ↓ H H

[Keys] 1 : ON 0 : OFF - : ON or OFF
 H : Hold ↑ : Increase ↓ : Decrease



SYSTEM CONFIGURATION EXAMPLES

- Holding and Manual Backup in Case of Computer Failure
- AB2 Used Independently
- AB2 – ST/STL Combination

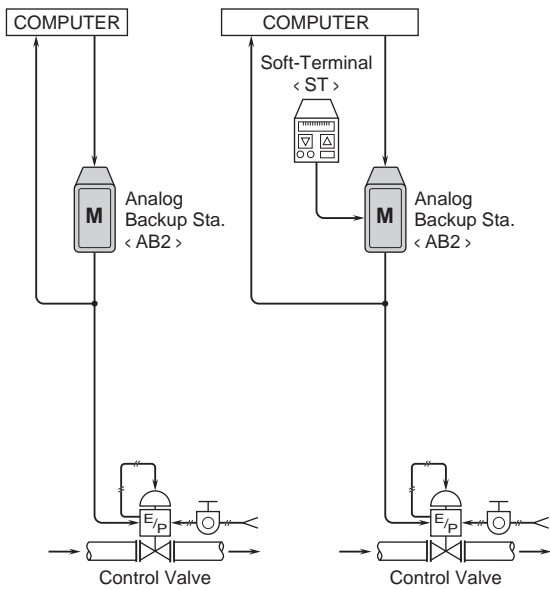

- Field Backup for a DDC Control Loop
- AB2 – ST/STL Combination

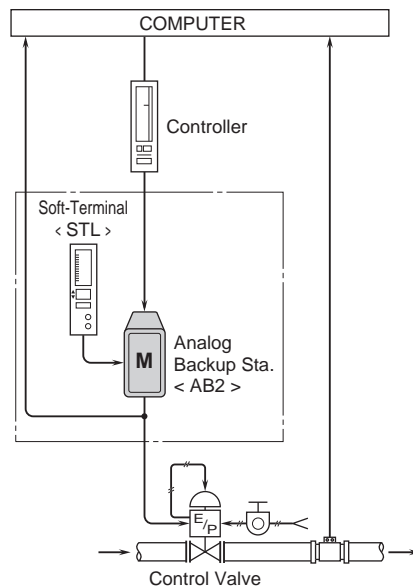

- Field Backup for Computer Outputs

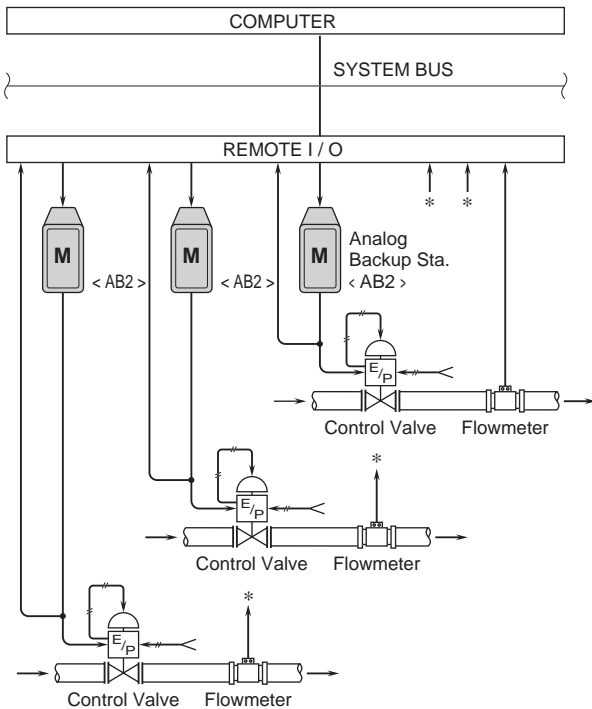

- Operator Control Station

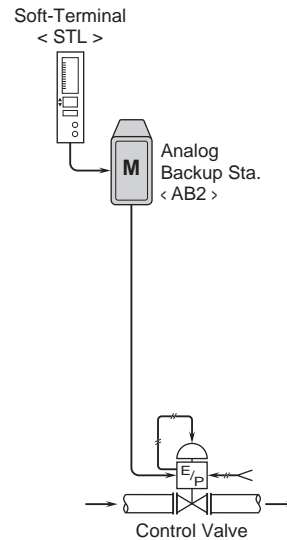

Specifications are subject to change without notice.