

Power Transducer Series

MULTI POWER MONITOR

(4 digital displays, LonWorks)

Functions & Features

- LonWorks communication
- Measures simultaneously several variables of a heavy-current power system: current, voltage, active, reactive and apparent power, active and reactive energy, power factor, frequency, etc.
- All measured values, counter values, display mode, setting data are stored in the non-volatile memory at the power off
- Parameters are programmable using the front keys or the PC via infrared interface
- Mounted using M5 screws or mounting brackets
- 60-segment bargraph
- Displayed measurands are freely selectable
- Open collector output for alarm or energy count
- Loop test output

Typical Applications

- Multi-functional power monitor incorporated in an electric device: saves space, wiring works, and cost

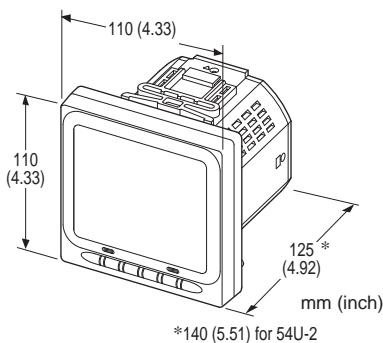

MODEL: 54UL-[1][2][3][4]-AD4[5]

ORDERING INFORMATION

- Code number: 54UL-[1][2][3][4]-AD4[5]
- Specify a code from below for each [1] through [5].
(e.g. 54UL-1211-AD4/E)

[1] CONFIGURATION

- 1: Single-phase / 2-wire and 3-wire, 3-phase / 3-wire
- 2: Single-phase / 2-wire and 3-wire,
3-phase / 3-wire and 4-wire

[2] INPUT

- 1: 480 V / 1 A AC
- 2: 480 V / 5 A AC

[3] DISCRETE INPUT

- 0: None ('External Interface' code 1 Not selectable.)
- 1: 24V DC ('External Interface' codes 2 Not selectable.)
- 2: 110V DC ('External Interface' codes 2 Not selectable.)

[4] EXTERNAL INTERFACE

- 1: LonWorks, Do × 1, Di × 1
- 2: LonWorks, Do × 2

AUXILIARY POWER SUPPLY

AD4: universal

100 - 240 V AC (Operational range 85 - 264 V, 50 / 60 Hz) /
110 - 240 V DC (Operational range 99 - 264 V,
ripple 10 %p-p max)

[5] OPTIONS

Language

- blank: Japanese
/E: English

RELATED PRODUCTS

- Infrared Communication Adaptor (model: COP-IRU)
- PC configurator software (model: PMCFG)
- XIF File (Device Interface File)

XIF file is used to define a LonWorks device when programmed on LonMaker.

The XIF files and Software are downloadable at M-System's web site.

GENERAL SPECIFICATIONS

Construction: 110-mm square panel flush mounted

Degree of protection

Front panel: IP 50

Terminal block, housing: IP 30

Connection

Voltage input: M4 screw terminals (torque 1.4 N·m)

Current input: M4 screw terminals (torque 1.4 N·m)

Output, power: M3 screw terminals (torque 0.6 N·m)

Configuration

Code 1: Single phase/2-wire and 3-wire, 3-phase/3-wire
balanced/unbalanced load

Code 2: Single phase/2-wire and 3-wire, 3-phase/3-wire
balanced/unbalanced load, 3-phase/4-wire
balanced/unbalanced load

Housing material: Flame-resistant resin (black)



幸託有限公司
XIN TOP CORPORATION

TEL : (02)2598-1199
FAX : (02)2596-2331

E-mail : info@xintop.com
Website : www.xintop.com

Isolation: Voltage input to current input to discrete input to LonWorks or FG to discrete output to power

Measured variables

Voltage: 1 - 2, 2 - 3, 3 - 1, 1 - N, 2 - N, 3 - N

Current: 1, 2, 3, N

Active / reactive / apparent power: 1, 2, 3, Σ

Power factor: 1, 2, 3, Σ

Frequency

Phase angle between voltages: 1 - 2, 2 - 3, 3 - 1

Active energy incoming / outgoing: Σ

Reactive energy inductive / capacitive: Σ

Apparent energy: Σ

Active / reactive / apparent power intervals (demand)

Current intervals (demand): 1, 2, 3, N

Harmonic contents: Σ , 2nd to 31st

Voltage: 1 - 2, 2 - 3, 3 - 1, 1 - N, 2 - N, 3 - N

Current: 1, 2, 3, N

Max. and min. values: 1 = R, 2 = S, 3 = T

■ **DISPLAY:** LCD with LED backlight (LED OFF timer available)

Signed: 4 digits, 2 lines

Energy: 9 digits, 1 line

Bargraph: 1 point (60 segments)

INPUT SPECIFICATIONS

Frequency: 50 / 60 Hz (45 - 65 Hz)

• **Voltage Input**

Rated voltage

Line-to-line (delta voltage): 480 V

Line-neutral (phase voltage): 277 V

Consumption VA: $\leq U_{LN}^2 / 300 \text{ k}\Omega / \text{phase}$

Overload capacity: 200 % of rating for 10 sec., 120 % continuous

Selectable primary voltage range: 50 - 400 000 V

• **Current Input**

Rated current: 1 A or 5 A

Consumption VA: $\leq I^2 \cdot 0.01 \Omega / \text{phase}$

Overload capacity: 4000 % of rating for 1 sec., 2000 % for 4 sec., 120 % continuous

Selectable primary current range: 1 - 20 000 A

Operational range

Voltage, current, apparent power: $\leq 120 \%$ of the rating

Active / reactive power: -120 to +120 % of the rating

Frequency: 45 - 65 Hz

Power factor: -1 to +1

■ **Contact Input:** 24 V DC or 110 V DC (input resistance 6 k Ω)

Detecting voltage: External 24 V DC $\pm 10 \%$ or 110 V DC $\pm 10 \%$

ON current: $\geq 1 \text{ mA}$ ($\leq 24 \text{ k}\Omega @ 24 \text{ V}$, $\leq 110 \text{ k}\Omega @ 110 \text{ V}$)

OFF current: $\leq 0.1 \text{ mA}$ ($\geq 240 \text{ k}\Omega @ 24 \text{ V}$, $\geq 1.1 \text{ M}\Omega @ 110 \text{ V}$)

Detecting time: 10 - 1000 msec.

Usable to reset energy count or to update average (demand) value.

OUTPUT SPECIFICATIONS

■ **LonWorks**

Neuron chip: FT3150 (NeuronID printed in numeric and bar code [peel-off code 39 format] under the specification marking on the product; two sticker labels attached)

Transceiver: FT-X1 (equivalent to FTT-10A)

Transmission speed: 78 kbps Twisted-pair cable

Distance, free topology: 500 meters

Max. 64 nodes/channel

LNS: Ver.3.0 Service Pack 8 or higher

Service lamp: Red LED (used as infrared LED for communication with COP-IRU)

- Off: Normal operations
- Blinking in approx. 0.5 Hz: No network information
- On: Internal program error

SERVICE switch: Used to identify the node in LonWorks network configuration

RESET switch: Resetting the Neuron Chip

■ **Open Collector**

Programmable for either alarm or energy count.

Max. rated load: 130 V DC @50 mA

Continuous rated load: 130 V DC @30 mA

Saturation voltage: 1.5 V DC

Measurands applicable to alarm: Voltage, current, average current (demand), neutral current, frequency, power, average power (demand)

(ON delay, deadband and other parameters are selectable)

Measurands applicable to count: Energy;

Pulse rate selectable within

0.1 - 10 000.0 kWh/p, kvarh/p, kVAh/p

INSTALLATION

Power input

• **AC:** < 8 VA

• **DC:** < 4 W

Operating temperature: -10 to +55°C (14 to 131°F)

Storage temperature: -20 to +80°C (-4 to +176°F)

Operating humidity: 90 % RH max. (non-condensing)

Mounting: Panel flush mounting (M5 screws (torque 2 N·m) or mounting brackets)

Weight

Configuration Code 1: 500 g (1.1 lb)

Configuration Code 2: 525 g (1.16 lb)



PERFORMANCE

Accuracy

(at 23°C ±10°C or 73.4°F ±18°F, 45 - 65 Hz)

Voltage: ±0.3 %; Rated voltage at ≥ 100 V, 100 V at < 100 V

Current: ±0.3 %; of Span 1 A or 5 A

Power: ±0.5 %; Rated voltage/current at ≥ 100 V

Wattage as listed below at < 100 V:

173.2 W (1 A) or 866 W (5 A) for 3ph/3w

100 W (1 A) or 500 W (5 A) for 1ph/2w

200 W (1 A) or 1000 W (5 A) for 1ph/3w

300 W (1 A) or 1500 W (5 A) for 3ph/4w

PF: ±0.5 %

Frequency: ±0.1 % of Span

Energy: ±1 %

Harmonic: ±1 % of Span

Sampling time:

Harmonic contents and frequency: ≤ 1.1 sec.

Other: ≤ 600 msec.

Insulation resistance: ≥ 100 MΩ with 500 V DC

Dielectric strength: 2000 V AC @ 1 minute

(voltage input to current input to discrete input to LonWorks or FG to discrete output to power)

2000 V AC @1 minute (circuits to housing)

MOUNTING REQUIREMENTS

■ **PANEL CUTOUT** unit: mm (inch)

• **USING MOUNTING SCREWS**

Remove the mounting brackets.

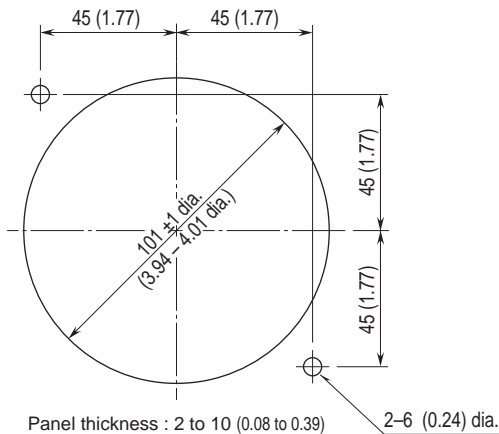

• **USING MOUNTING BRACKETS**

Remove the mounting screws.

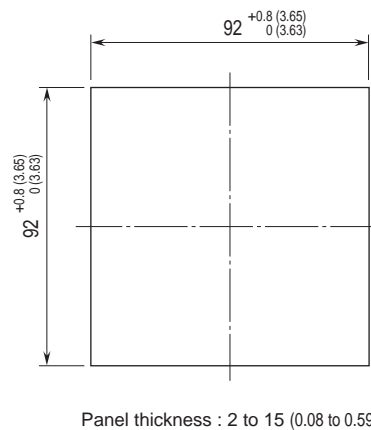

EXTERNAL VIEW

■ FRONT VIEW

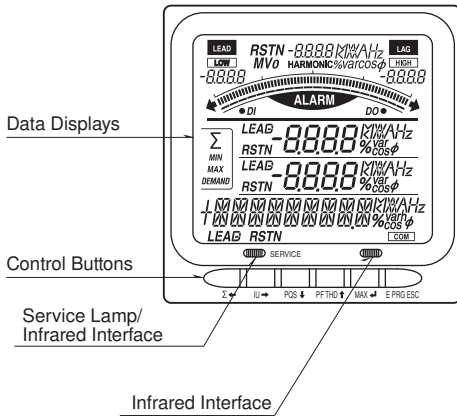

■ REAR VIEW

• Configuration Code 1

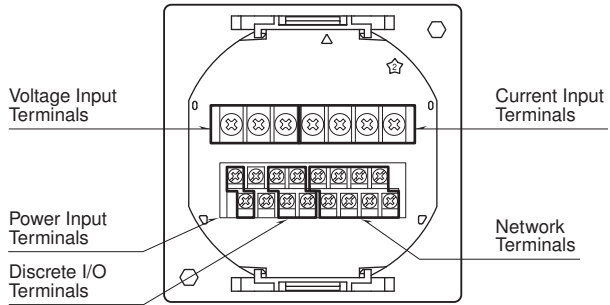

• Configuration Code 2

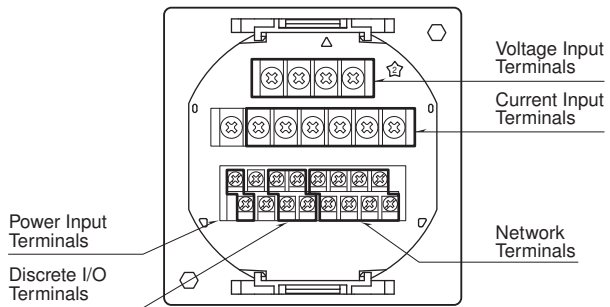

TERMINAL CONNECTIONS

• Configuration Code 1

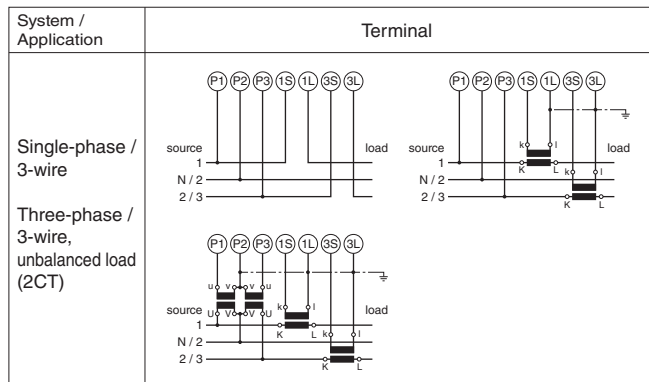
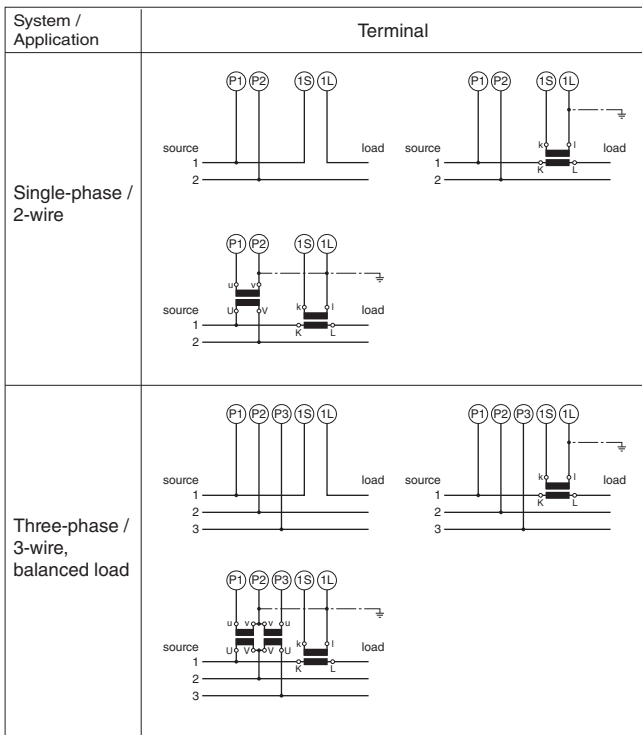
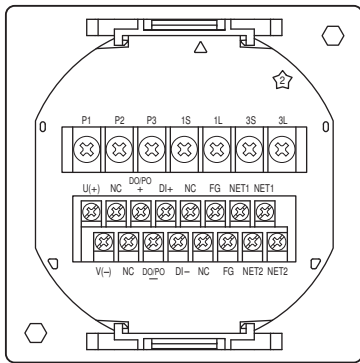

• Configuration Code 2

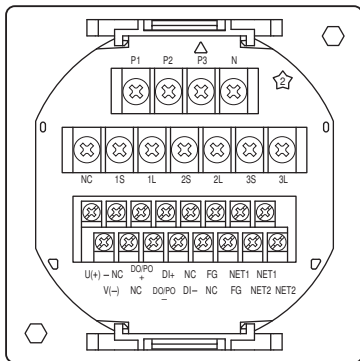

System / Application	Terminal	System / Application	Terminal
Single-phase / 2-wire		Single-phase / 3-wire Three-phase / 3-wire, unbalanced load (2CT)	
Three-phase / 3-wire, balanced load		Three-phase / 4-wire, balanced load	
Three-phase / 3-wire, unbalanced load (3CT)		Three-phase / 4-wire, unbalanced load	



EXTERNAL INTERFACE CODE: 1

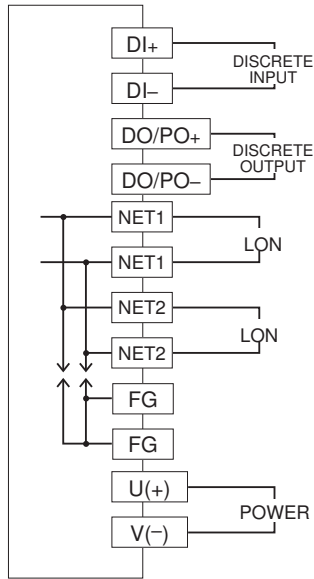

EXTERNAL INTERFACE CODE: 2

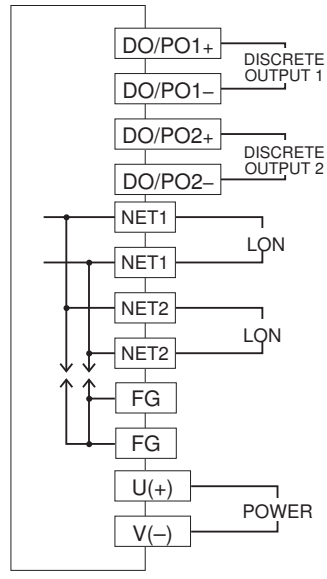

Discrete Input Connection E.g.

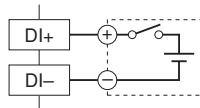

Discrete Output Connection E.g.

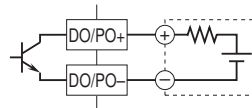

COMMUNICATION CABLE CONNECTIONS

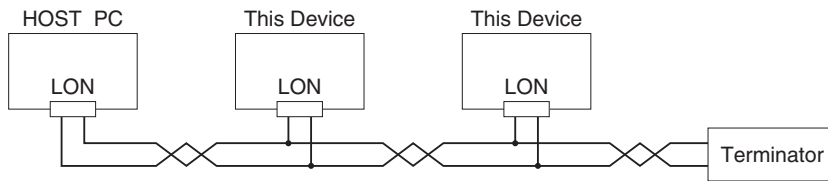

DIMENSIONS unit: mm (inch)

CONFIGURATION CODE 1

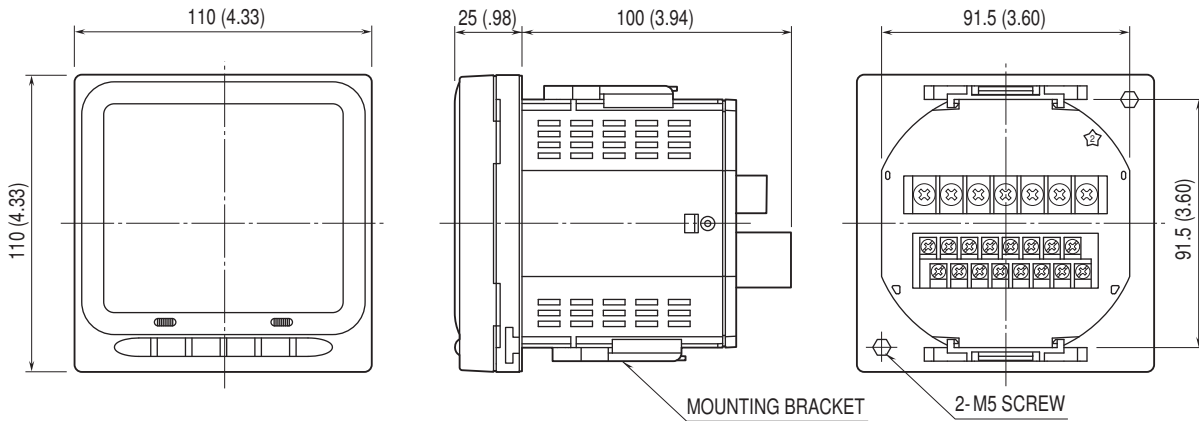

CONFIGURATION CODE 2

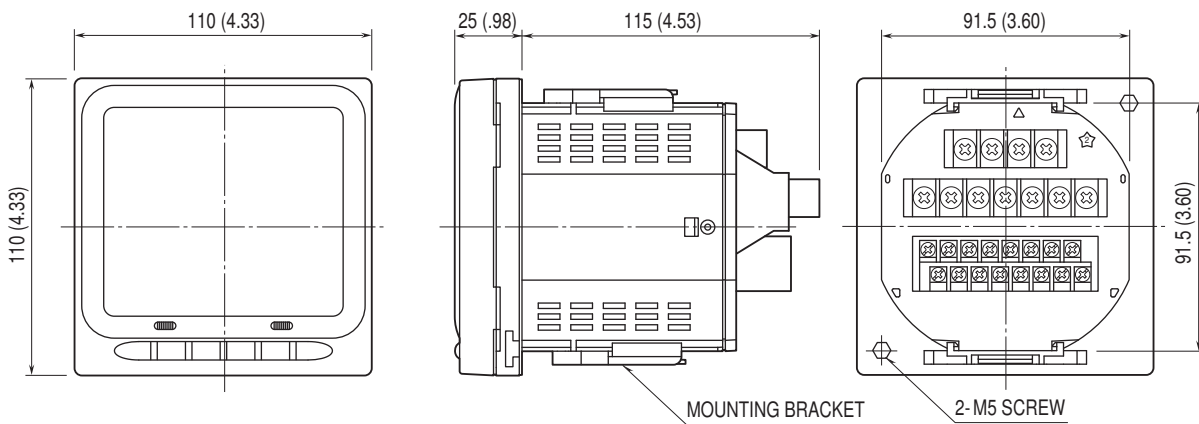

Specifications are subject to change without notice.

