

## Bargraph Indicators 48N Series

### BARGRAPH INDICATING ALARM

(with 4-digit digital meter; with isolated DC output)

#### Functions & Features

- Displays a process variable in graphic bargraph of 101 LED segments
- Clear 4-digit digital meter
- Provides max. 4 alarm contact outputs
- Isolated DC signal output
- Multi-color indicator
- LED brightness adjustment
- IP65 front cover
- Scale plate is easily replaced
- Separable terminal block

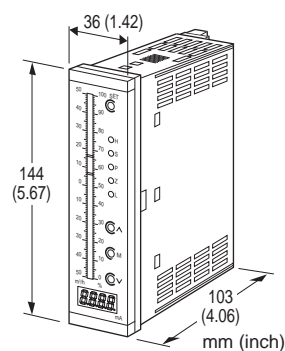

### MODEL: 48NDVA-[1][2][3][4]-[5][6]

#### ORDERING INFORMATION

- Code number: 48NDVA-[1][2][3][4]-[5][6]
- Specify a code from below for each [1] through [6].  
(e.g. 48NDVA-4233-R/CE/D/Q)
- Special input and DC output ranges (For codes Z & 0)
- Bargraph scale (e.g. 0 - 100 %) (See 'Scale Plate.')
- Digital indicator scale (e.g. 0.0 - 130.0)
- Specify the specification for option code /Q  
(e.g. /SET)

#### [1] ALARM OUTPUT

- 0: None
- 2: 2 points
- 4: 4 points

#### [2] BAR LED COLOR

- R: Red
- Y: Amber
- G: Green

B: Blue

- 1: Multi-color (red, orange and green), Pattern 1  
(See 'External View.')
- 2: Multi-color (red, orange and green), Pattern 2  
(See 'External View.')

#### [3] INPUT

##### Current

- A: 4 - 20 mA DC (Input resistance 10  $\Omega$ )
- B: 2 - 10 mA DC (Input resistance 20  $\Omega$ )
- C: 1 - 5 mA DC (Input resistance 39  $\Omega$ )
- D: 0 - 20 mA DC (Input resistance 10  $\Omega$ )
- E: 0 - 16 mA DC (Input resistance 12  $\Omega$ )
- F: 0 - 10 mA DC (Input resistance 20  $\Omega$ )
- G: 0 - 1 mA DC (Input resistance 200  $\Omega$ )
- H: 10 - 50 mA DC (Input resistance 5.1  $\Omega$ )
- Z: Specify current (See INPUT SPECIFICATIONS)

##### Voltage

- 3: 0 - 1 V DC (Input resistance 1 M $\Omega$  min.)
- 4: 0 - 10 V DC (Input resistance 1 M $\Omega$  min.)
- 5: 0 - 5 V DC (Input resistance 1 M $\Omega$  min.)
- 6: 1 - 5 V DC (Input resistance 1 M $\Omega$  min.)
- 0: Specify voltage (See INPUT SPECIFICATIONS)

#### [4] DC OUTPUT

##### Current

- A: 4 - 20 mA DC (Load resistance 550  $\Omega$  max.)
- D: 0 - 20 mA DC (Load resistance 550  $\Omega$  max.)
- Z: Specify current (See OUTPUT SPECIFICATIONS)

##### Voltage

- 3: 0 - 1 V DC (Load resistance 1000  $\Omega$  min.)
- 4: 0 - 10 V DC (Load resistance 10 k $\Omega$  min.)
- 5: 0 - 5 V DC (Load resistance 5000  $\Omega$  min.)
- 6: 1 - 5 V DC (Load resistance 5000  $\Omega$  min.)
- 0: Specify voltage (See OUTPUT SPECIFICATIONS)

#### [5] POWER INPUT

##### AC Power

- M: 85 - 264 V AC (Operational voltage 85 - 264 V, 50/60 Hz  
(CE marking not available))
- M2: 100 - 240 V AC (Operational voltage range 85 - 264 V, 50/60 Hz)

##### DC Power

- R: 24 V DC  
(Operational voltage range 24 V  $\pm$ 15 %, ripple 10 %p-p max.)

#### [6] OPTIONS (multiple selections)

##### Standards & Approvals

- blank: Without CE
- /CE: CE marking

##### Bezels



**blank:** Bezels for M-System's 48 Series panel cutout  
**/D:** Bezels for DIN panel cutout  
**/F:** Bezels for Fuji Electric's PAJ, PAK, PBA panel cutout

## Other Options

**blank:** none  
**/Q:** Option other than the above (specify the specification)

## SPECIFICATIONS OF OPTION: Q

### EX-FACTORY SETTING

**/SET:** Preset according to the Ordering Information Sheet (No. ESU-9436)

## BEZEL OPTION

Bezels are used to adapt the 48N Series to an existing panel cutout. In order to replace M-System's 48 Series products, use the one attached to the 48N Series as standard. When the existing panel is cut according to DIN standard, specify '/D' suffix code.

For a new installation, no bezel is required. Please refer to 'Mounting Requirement' and mount the 48N directly. Ingress protection is invalid when the 48N is mounted with a bezel, or when multiple modules are stacked side by side.

## SPARE PARTS

- Scale plate

## GENERAL SPECIFICATIONS

**Construction:** Panel flush mounting  
**Degree of protection:** IP65; applicable to the front panel for single unit mounted according to the specified panel cutout  
**Connection:** M3 separable screw terminal (torque 0.6 N·m)  
**Screw terminal:** Nickel-plated steel  
**Housing material:** Flame-resistant resin (black)  
**Isolation:** Input to DC output to alarm output to power  
**Display zero adjustment:** -10 to +10 %  
**DC output zero adjustment:** -2 to +2 %  
**Display span adjustment:** 90 to 110 %  
**DC output span adjustment:** 98 to 102 %  
**Scale plate:** Flame resistant resin (white scale & characters on black base)  
**H & L alarm output delay:** 0 sec. (factory setting; fieldselectable between 0 and 15 sec. by 1 sec. increments)  
**Setpoint adjustment**  
**2 points:**  
H [L setpoint ] to 100 %  
L 0 to [H setpoint]  
or No alarm trip  
**4 points:**  
HH [H setpoint] to 100 %  
H [L setpoint] to [HH setpoint]

L [LL setpoint] to [H setpoint]  
LL 0 to [L setpoint]  
or No alarm trip

**Alarm deadband (hysteresis):** 1 %

**Setting:** (Front button)

- Zero and span adjustments
- Alarm setpoint
- Others

(Refer to the instruction manual for details)

**Read rate:** 10/s

**Moving average sample number:** 4 (factory setting; field selectable among 1, 2, 4, 8 or 16)

**Simulated output:** Programmable within 0 - 100 %

**LED brightness adjustment:** 7 levels

### ■ BARGRAPH

**LED:** 101-segment LED, 100 mm (3.96") long, 3.00 mm (.12") wide

**Display range:** 0 to 100 (scaling function not available) (0 % or 100 % position bar blinks when over range)

**Scale:** Two different scales available for single bargraph

**Characters:** Max. 4 characters including decimal point and negative sign

**Divisions:** Min. 22, max. 100

**Engineering unit:** Max. 6 characters

### ■ DIGITAL DISPLAYS

**LED:** 7-segment red LED, character 8 mm (.31") high

**Number of digits:** 4 digits

**Setting range:** -1999 to 9999

(Min. 3 significant digits)

**Minimum scale value:** 100 (3 digits, the decimal point position disregarded)

**Scaled range:** The range between -1999 to 9999 and -15 to +115 % of input span

(The indicator blinks when the input is out of the range)

**Decimal point position:**  $10^{-1}$ ,  $10^{-2}$ ,  $10^{-3}$  or none

**Zero indication:** Higher-digit zeros are suppressed

**Engineering unit:** Max. 6 characters on scale plate

## INPUT SPECIFICATIONS

■ **DC Current:** 0 - 50 mA DC; input resistor incorporated

**Minimum span:** 1 mA

When specifying a resistance value, choose from below.

5.1 Ω, 10 Ω, 12 Ω, 20 Ω, 39 Ω, 200 Ω

■ **DC Voltage:** -10 - +10 V DC

**Input resistance:** ≥ 1 MΩ

**Minimum span:** 0.1 V

**Offset:** Max. 1.5 times span



## OUTPUT SPECIFICATIONS

### DC Output

■ **DC Current:** 0 - 20 mA DC

**Minimum span:** 1 mA

**Offset:** Max. 1.5 times span

**Load resistance:** Output drive 11 V max.

■ **DC Voltage:** -10 - +10 V DC

**Minimum span:** 1 V

**Offset:** Max. 1.5 times span

**Load resistance:** Output drive 1 mA max.; at  $\geq 0.5$  V

■ **Alarm Output:** Relay contact

**Rated load:** 250 V AC @1 A ( $\cos \phi = 1$ )

30 V DC @5 A (resistive load)

**Maximum switching voltage:** 250 V AC, 220 V DC

**Maximum switching power:** 380 VA, 150 W

**Minimum load:** 5 V DC @100 mA

**Mechanical life:**  $\geq 5 \times 10^8$  cycles (rate 180 cycles/min.)

Approx. 3.5 W at 24 V with max. load

Approx. 3.5 W at 27.6 V with max. load

**Operating temperature:** -5 to +55°C (23 to 131°F)

**Operating humidity:** 30 to 90 %RH (non-condensing)

**Mounting:** Panel flush mounting

**Weight:** 300 g (0.66 lb)

## PERFORMANCE in percentage of span

**Accuracy:**  $\pm 1$  %  $\pm 1$  digit ( bargraph)

$\pm 0.5$  %  $\pm 1$  digit (digital indicator)

$\pm 0.1$  % DC output

**Temp. coefficient:**

$\pm 0.015$  % of FS/°C ( $\pm 0.008$  % of FS/°F) (Display)

$\pm 0.02$  %/°C ( $\pm 0.01$  %/°F) (DC output)

**Response time:**

$\leq 0.5$  sec. (Display: moving average sample number set to 4)

$\leq 1.0$  sec. (DC output : 0 - 90 %)

**Insulation resistance:**  $\geq 100$  M $\Omega$  with 500 V DC

**Dielectric strength:** 2000 V AC @1 min. (input to DC output to alarm output to power to ground)

## STANDARDS & APPROVALS

**CE conformity:**

EMC Directive (2004/108/EC)

EMI EN 61000-6-4: 2007/A1: 2011

EMS EN 61000-6-2: 2005

Low Voltage Directive (2006/95/EC)

EN 61010-1: 2010

Installation Category II

Pollution Degree 2

Input to alarm output to power:

Reinforced insulation (300 V)

DC output to power: Reinforced insulation (300 V)

### Alarm Trip Operation

Terminal No. in parentheses

#### • Alarm Suffix Code 2

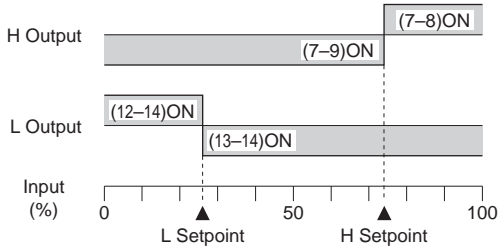

#### • Alarm Suffix Code 4

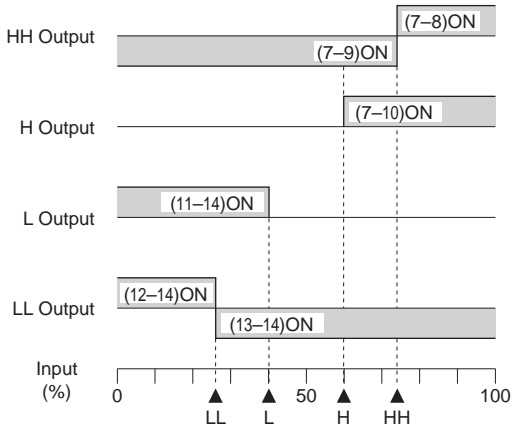

## INSTALLATION

### Power Consumption

#### •AC:

Approx. 5.5 VA at 100 V with max. load

Approx. 7 VA at 200 V with max. load

Approx. 8 VA at 264 V with max. load

#### •DC

Approx. 3.5 W at 20.4 V with max. load



**幸託有限公司**  
XIN TOP CORPORATION

TEL : (02)2598-1199

FAX : (02)2596-2331

E-mail : info@xintop.com

Website : www.xintop.com

## SCALE PLATE

### ■ WHAT MUST BE SPECIFIED WHEN ORDERING

Please specify the bargraph scale range and engineering unit. The overall scale plate design including the number of divisions, division line length, character font is determined by M-System.

[Example] : Bargraph range 0 to 300 cm  
 Bargraph scale range: 0 – 300  
 Engineering unit for the bargraph: cm

### ■ TYPES OF DIVISIONS

Five (5) types of divisions are used depending upon the scale span, which determined by the following equation:

$$\text{Scale Span} = (\text{Max. range value} - \text{Min. range value}) \times 10^n$$

where n = integer (used to limit the calculated scale span to the minimum of 1.1, below 11.0.)

The number of divisions is automatically determined by the scale span.

#### • Type 1: 1.1 Scale Span < 1.3

Number of divisions: 22 to 25.9

Scale: Starts at 0, increments by 0.02 / 0.2 / 2 / 20 / 200. Min. and max. values indicated. 4 digits including negative sign and decimal point.

Division lines: Long, Short, Medium, Short, Long (4 divisions repeated)

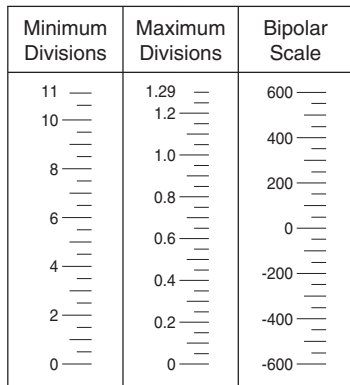

#### • Type 3: 2.0 Scale Span < 2.6

Number of divisions: 40 to 51.9

Scale: Starts at 0, increments by 0.05 / 0.5 / 5 / 50 / 500. Min. and max. values indicated. 4 digits including negative sign and decimal point.

Division lines: Long, Short, Medium, Short, Medium, Short, Medium, Short, Long (10 divisions repeated)

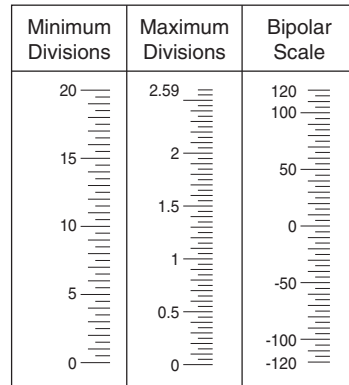

#### • Type 2: 1.3 Scale Span < 2.0

Number of divisions: 26 to 39.9

Scale: Starts at 0, increments by 0.03 / 0.3 / 3 / 30 / 300. Min. and max. values indicated. 4 digits including negative sign and decimal point.

Division lines: Long, Short, Medium, Short, Medium, Short, Long (6 divisions repeated)

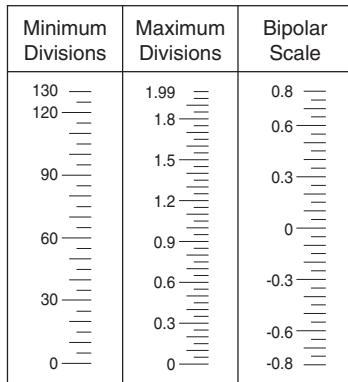

#### • Type 4: 2.6 Scale Span < 5.5

Number of divisions: 26 to 54.9

Scale: Starts at 0, increments by 0.05 / 0.5 / 5 / 50 / 500. Min. and max. values indicated. 4 digits including negative sign and decimal point.

Division lines: Long, Medium, Medium, Medium, Long (5 divisions repeated)

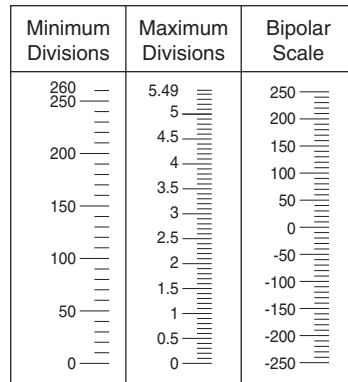

# MODEL: 48NDVA

• **Type 5: 5.5 Scale Span < 11.0**

Number of divisions: 27.5 to 54.9

Scale: Starts at 0, increments by 0.01 / 0.1 / 1 / 10 /

100 / 1000. Min. and max. values indicated.

4 digits including negative sign and decimal point.

Division lines: Long, Medium, Medium, Medium, Medium, Long (5 divisions repeated)

Minimum Divisions	Maximum Divisions	Bipolar Scale
550	10.9	0.5
500	10	0.4
	9	0.3
400	8	0.2
	7	0.1
300	6	0
	5	-0.1
200	4	-0.2
	3	-0.3
100	2	-0.4
	1	-0.4
0	0	-0.5

[Example] : Bargraph range 0 to 300 cm (Type 4)

Digital indicator range 0.00 to 6.75 m<sup>3</sup>

(Type 4)

Left scale range: 0 – 300

Left scale unit (bargraph): cm

Right scale: None

Digital indicator unit: m<sup>3</sup>



## EXTERNAL VIEW

### ■ ALARM SUFFIX CODE 0: None

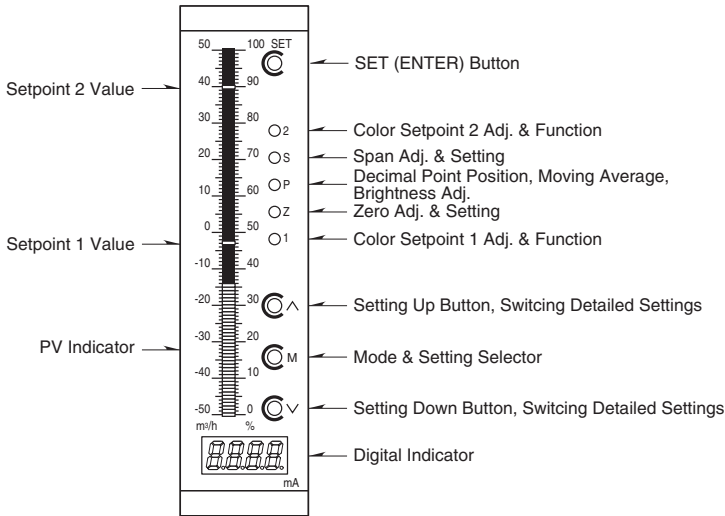

Setpoint 1 or 2 provided only for the multi-color bar type.

### • Bar Color Patterns

Pattern 1 (model suffix code 1)

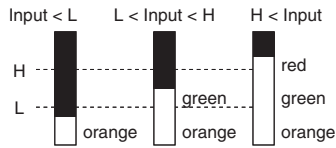

Pattern 2 (model suffix code 2)

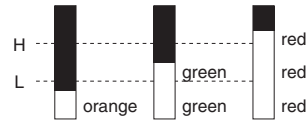

### ■ ALARM SUFFIX CODE 2: 2 points

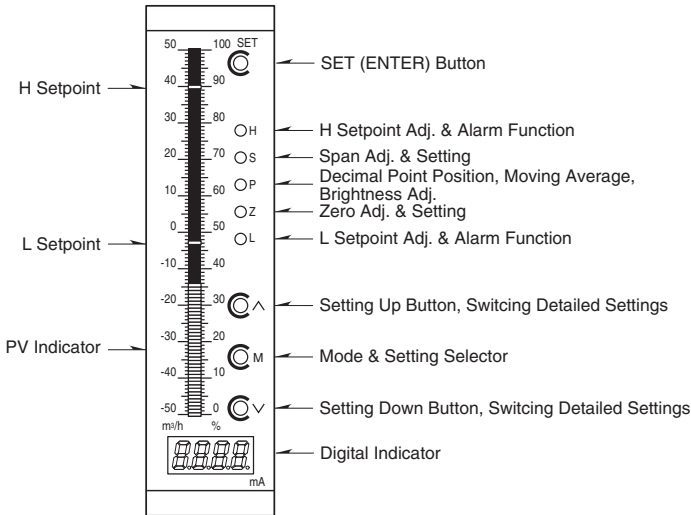

### ■ ALARM SUFFIX CODE 4: 4 points

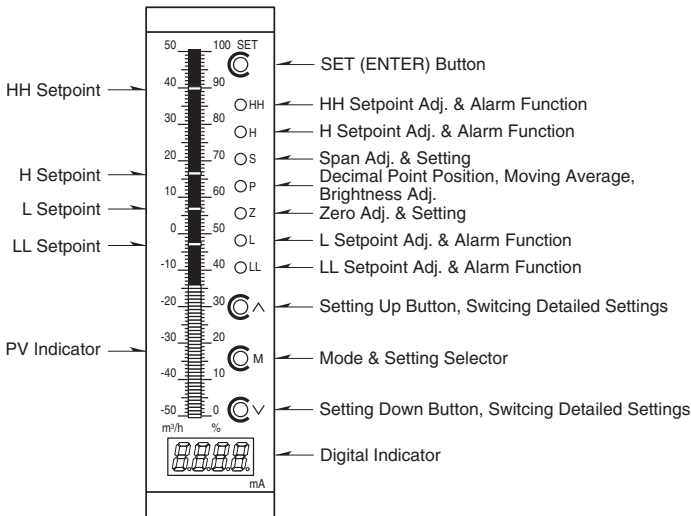

**DIMENSIONS unit: mm (inch)**

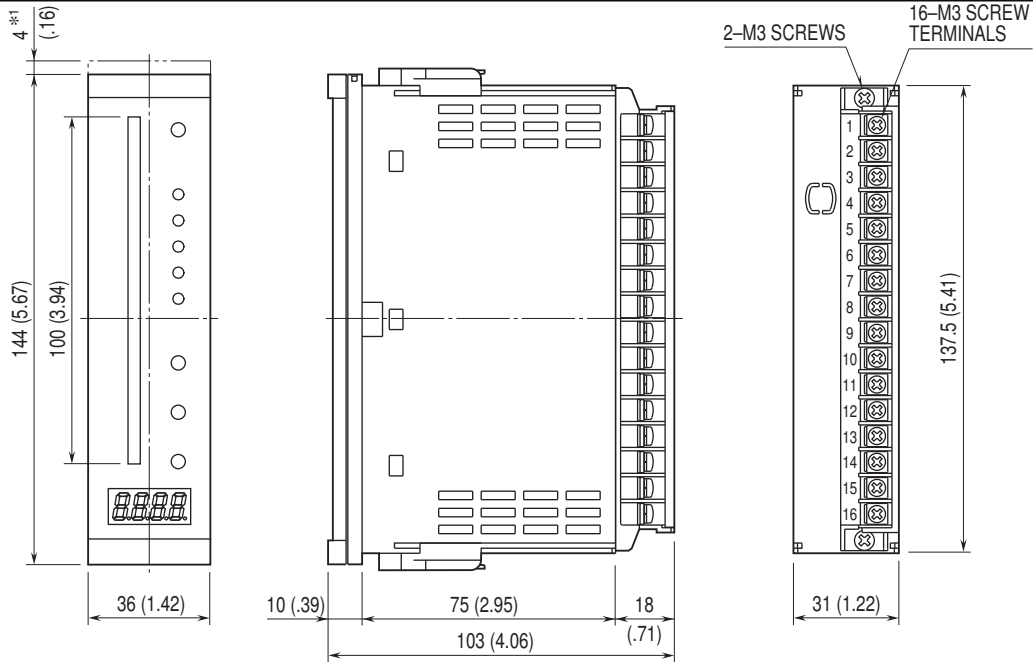

**STANDARD BEZEL** \*2

**OPTION /D BEZEL** \*3

**OPTION /F BEZEL** \*4

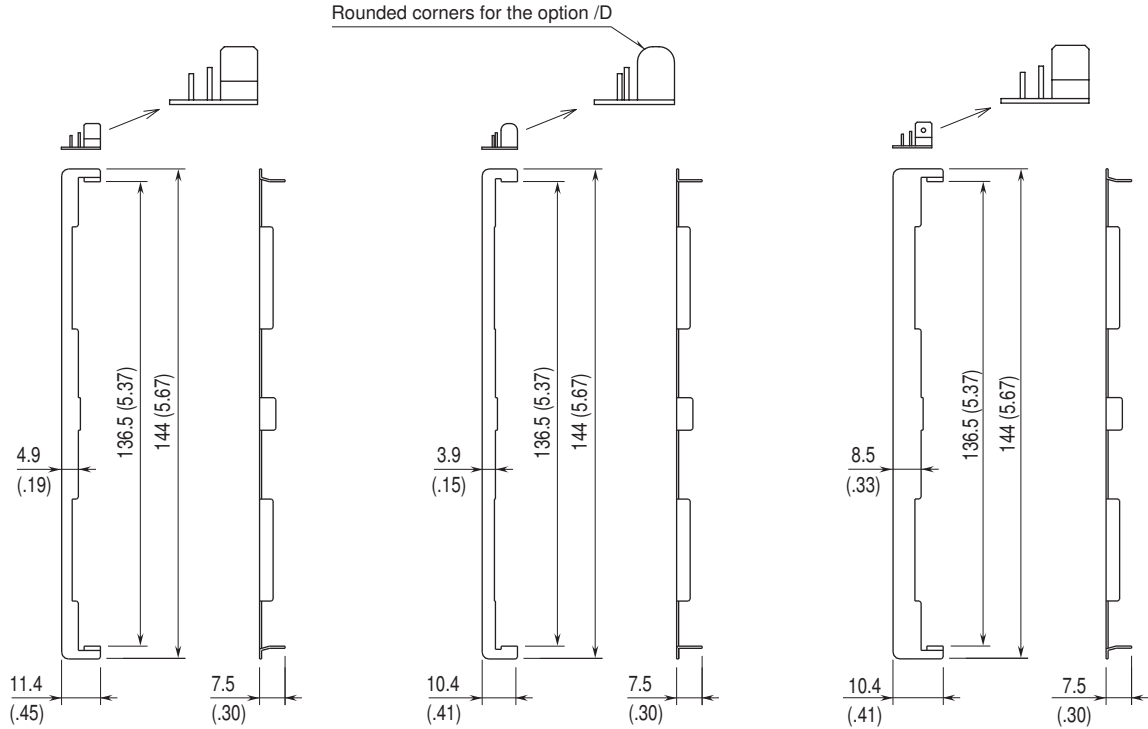

\*1. Space required when replacing the scale plate.  
 \*2. Used for the existing panel cutout of M-System 48 Series (38 × 139.5 mm).  
 \*3. Used for the existing DIN panel cutout (33 × 138 mm)  
 \*4. Used for the existing panel cutout of Fuji Electric PAJ, PAK, PBA (44 × 138 mm), etc.



## PANEL CUTOUT unit: mm

- SINGLE MOUNTING (ingress protection)
- CLUSTERED MOUNTING (no ingress protection)

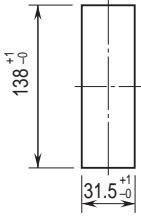

Panel thickness: 1.6 – 8.0 mm

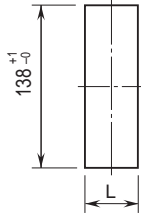

Panel thickness: 1.6 – 8.0 mm

$$L = \{31.5 + 36 \times (N - 1)\}^{+1}_{-0}$$

(N : number of units)

- Note 1. Observe at the minimum of 3 cm above and below the units for heat dissipation.
- Note 2. No bezel is needed when the panel is cut according to the left drawings.

## SCHEMATIC CIRCUITRY & CONNECTION DIAGRAM

### ■ ALARM SUFFIX CODE 0: None

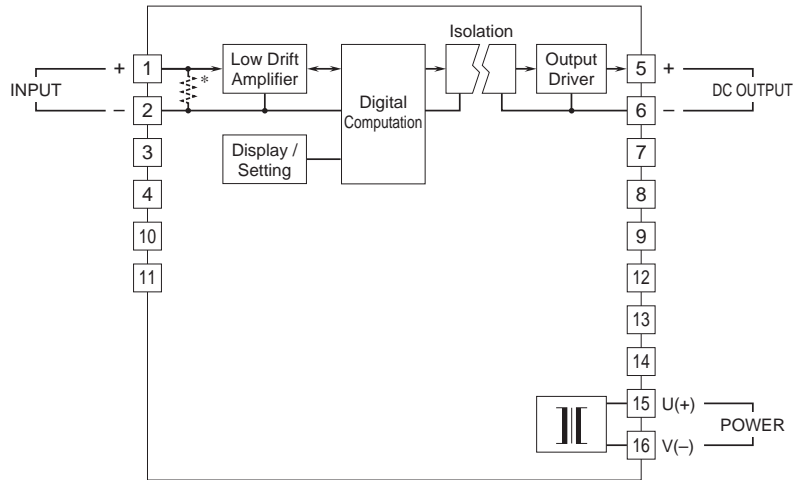

\*Input shunt resistor incorporated for current input.

### ■ ALARM SUFFIX CODE 2: 2 points

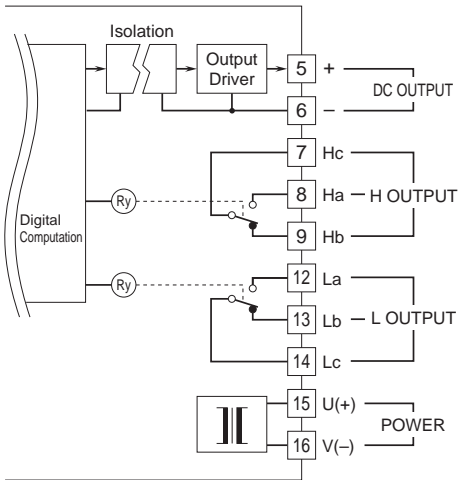

### ■ ALARM SUFFIX CODE 4: 4 points

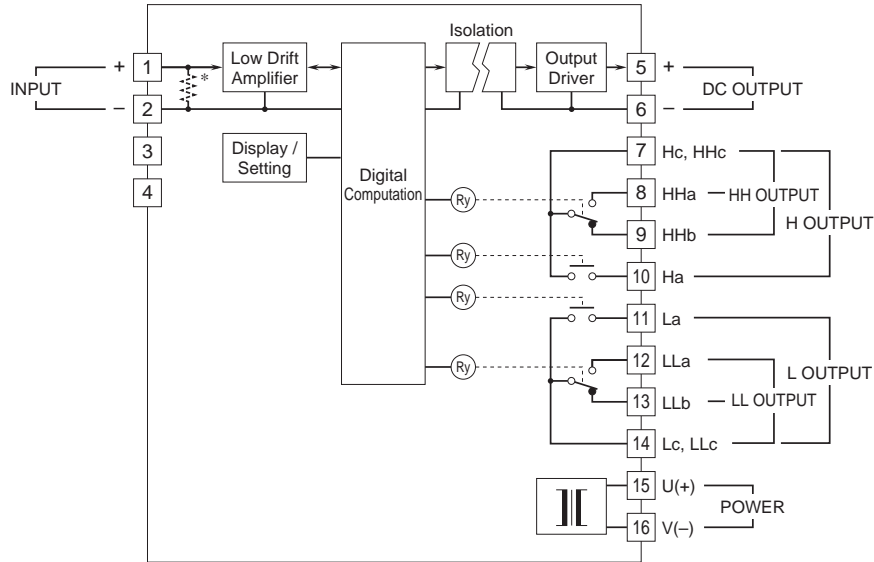

\*Input shunt resistor incorporated for current input.

#### ■ Relay Protection

##### • AC Powered

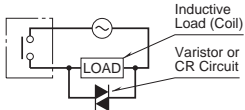

##### • DC Powered

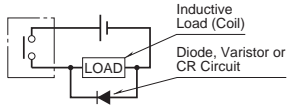





Specifications are subject to change without notice.

