

Rack-mounted DCS Signal Conditioners 18-RACK

RTD CONVERTER

Functions & Features

- Accepting direct input from an RTD and providing two standard process signals
- Linearization
- Burnout protection
- Second channel output available at the front terminals and at the Standard Rack connector

Typical Applications

- Converting into standard signals
- Power plant

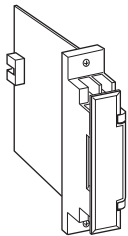

MODEL: 18RS-[1]6[2]-R[3]

ORDERING INFORMATION

- Code number: 18RS-[1]6[2]-R[3]
- Specify a code from below for each [1] through [3] (e.g. 18RS-166-R/BL)
- Temperature range (e.g. 0 - 100°C)

[1] INPUT RTD (2- or 3-wire)

1: JPt 100 (JIS'89)

(Usable range: -200 to +500°C, -328 to +932°F; min.span: 30°C, 54°F)

3: Pt 100 (JIS'89)

(Usable range: -200 to +650°C, -328 to +1202°F; min.span: 30°C, 54°F)

4: Pt 100 (JIS'97, IEC)

(Usable range: -200 to +650°C, -328 to +1202°F; min.span: 30°C, 54°F)

5: Pt 50 Ω (JIS'81)

(Usable range: -200 to +500°C, -328 to +932°F; min.span: 60°C, 108°F)

6: Ni 508.4 Ω

(Usable range: -50 to +200°C, -58 to +392°F; min.span: 20°C, 36°F)

0: Specify

Note: Consult M-System for 2-wire RTD

OUTPUT 1

Voltage

6: 1 - 5 V DC (Load resistance 2000 Ω min.)

[2] OUTPUT 2

Current

A: 4 - 20 mA DC (Load resistance 600 Ω max.)

Voltage

6: 1 - 5 V DC (Load resistance 2000 Ω min.)

POWER INPUT

DC Power

R: 24 V DC

(Operational voltage range 24 V ±10 %, ripple 10 %p-p max.)

[3] OPTIONS

Burnout

blank: Upscale burnout

/BL: Downscale burnout

GENERAL SPECIFICATIONS

Construction: Rack-mounted; terminal access via screw terminals on the front and connector on the rear; terminal cover provided

Connection

Input: M3.5 screw terminals (torque 0.8 N·m)

Output 1: Connector

Output 2: M3.5 screw terminals (torque 0.8 N·m) and connector

Power input: Supplied from connector

Screw terminal: Nickel-plated steel

Isolation: Input to output 1 to output 2 to power

Overrange output: Approx. -10 to +120 % at 1 - 5 V

Zero adjustment: -5 to +5 % (front)

Span adjustment: 95 to 105 % (front)

Linearization: Standard

INPUT SPECIFICATIONS

Maximum leadwire resistance: 20 Ω per wire (3-wire)

Sensing current: 2 mA

INSTALLATION

Power consumption

•DC:

Approx. 35 mA with voltage output

Approx. 65 mA with current output

Operating temperature: -5 to +55°C (23 to 131°F)

Operating humidity: 30 to 90 %RH (non-condensing)

Mounting: Standard Rack 18BX or 18KBX

Weight: 150 g (0.33 lbs)



PERFORMANCE in percentage of span

Accuracy: $\pm 0.2\%$

Temp. coefficient: $\pm 0.015\%/^{\circ}\text{C}$ ($\pm 0.008\%/^{\circ}\text{F}$)

Response time: ≤ 0.5 sec. (0 - 90 %)

Burnout response: ≤ 10 sec.

Line voltage effect: $\pm 0.1\%$ over voltage range

Insulation resistance: $\geq 100\ \text{M}\Omega$ with 500 V DC

Dielectric strength: 1500 V AC @ 1 minute

(input to output 1 or output 2 or power)

500 V AC @ 1 minute

(output 1 to output 2 to power)

1500 V AC @ 1 minute

(input or output or power to ground)

DIMENSIONS unit: mm (inch)

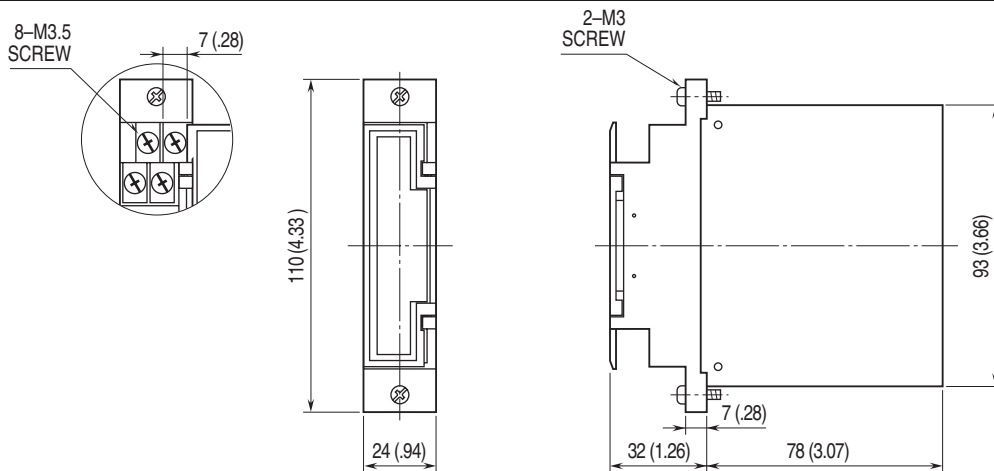

TERMINAL ASSIGNMENTS

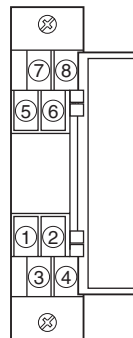

SCHEMATIC CIRCUITRY & CONNECTION DIAGRAM

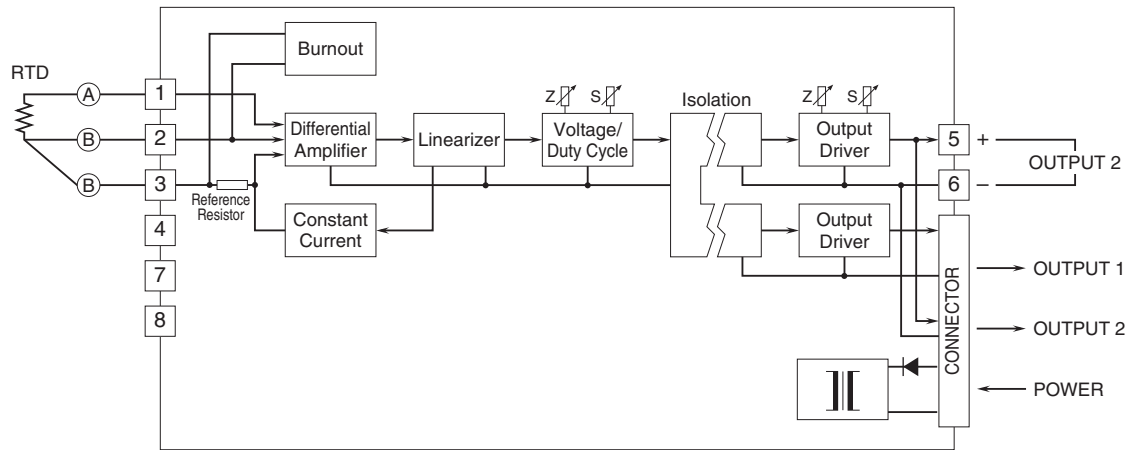

Note: Use either the front terminals or the connector for current output 2.



Specifications are subject to change without notice.

