

Rack-mounted DCS Signal Conditioners 18-RACK

THERMOCOUPLE ALARM

Functions & Features

- Providing relay contact closures at preset input levels
- Direct input from a thermocouple
- Burnout protection
- High-accuracy cold junction compensation
- Single or dual (Hi/Lo) trip
- Front accessed screwdriver setpoint adjustments
- Enclosed relays

Typical Applications

- Annunciator
- Various alarm applications

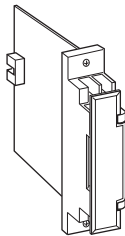

MODEL: 18AT-[1][2]-R[3]

ORDERING INFORMATION

- Code number: 18AT-[1][2]-R[3]
- Specify a code from below for each [1] through [3].
(e.g. 18AT-25-R/BL)
- Temperature range (e.g. 0 - 800°C)
- Use Ordering Information Sheet (No. ESU-1033) to specify alarm output code 0 specifications.

[1] INPUT THERMOCOUPLE

- 1: (PR) (Usable Range 0 to 1760°C, 32 to 3200°F)
- 2: K (CA) (Usable range -270 to +1370°C, -454 to +2498°F)
- 3: E (CRC) (Usable range -270 to +1000°C, -454 to +1832°F)
- 4: J (IC) (Usable range -210 to +1200°C, -346 to +2192°F)
- 5: T (CC) (Usable range -270 to +400°C, -454 to +752°F)
- 6: B (RH) (Usable range 0 to 1820°C, 32 to 3308°F)
- 7: R (Usable range -50 to +1760°C, -58 to +3200°F)
- 8: S (Usable range -50 to +1760°C, -58 to +3200°F)
- N: N (Usable range -270 to +1300°C, -454 to +2372°F)
- 0: Specify

[2] ALARM OUTPUT

- 1: Hi (coil energized at alarm)
- 2: Hi (coil de-energized at alarm)
- 3: Lo (coil energized at alarm)

- 4: Lo (coil de-energized at alarm)
- 5: Hi/Lo; N.O., OFF in power failure (connector output not available)
- 6: Hi/Lo; N.C., OFF in power failure (connector output not available)
- 0: Specify

POWER INPUT

DC Power

R: 24 V DC
(Operational voltage range 24 V ±10 %, ripple 10 %p-p max.)

[3] OPTIONS

Burnout

blank: Upscale burnout
/BL: Downscale burnout
/BN: No burnout

GENERAL SPECIFICATIONS

Construction: Rack-mounted; terminal access via screw terminals on the front and connector on the rear; terminal cover provided

Connection

Input: M3.5 screw terminals (torque 0.8 N·m)
Alarm output: M3.5 screw terminals (torque 0.8 N·m) and connector

Power input: supplied from connector

Screw terminal: Nickel-plated steel

Isolation: Input to output to power

Relay: Enclosed

Setpoint adjustments: Multi-turn screwdriver adjustments (front); -5 - +105 % independently

Cold junction compensation: CJC sensor attached to the input terminals (B thermocouple is without CJC as standard)

Hysteresis (deadband): Approx. 1 %

Front LEDs: Red light turns on when the coil is energized.

INPUT SPECIFICATIONS

Input: Thermocouples

Minimum span: 3 mV

Offset: Max. 1.5 times span

Input resistance: 20 kΩ minimum

Burnout sensing: 0.1 μA

(PR): Min. Span 370°C, 670°F

K (CA): Min. Span 75°C, 140°F

E (CRC): Min. Span 50°C, 90°F

J (IC): Min. Span 60°C, 110°F

T (CC): Min. Span 75°C, 140°F

B (RH): Min. Span 780°C, 1410°F

R: Min. Span 360°C, 650°F



S: Min. Span 380°C, 690°F

N: Min. Span 110°C, 200°F

(at over 400°C or 750°F for R, S and PR; over 770°C or 1420°F for B)

Response time: ≤ 0.5 sec. (0 – 100 % at 90 % setpoint)

Burnout response: ≤ 10 sec.

Line voltage effect: ±0.1 % over voltage range

Insulation resistance: ≥ 100 MΩ with 500 V DC

Dielectric strength: 1500 V AC @ 1 minute

(input to output or power)

500 V AC @ 1 minute (output to power)

1500 V AC @ 1 minute (input or output or power to ground)

OUTPUT SPECIFICATIONS

Output: Enclosed SPST and SPDT relays

Rating: 120 V AC @ 1 A (cos φ = 1)

30 V DC @ 1 A (resistive load)

0.2 A maximum for the connector output

Maximum switching voltage: 120 V AC or 30 V DC

Max. switching power: 120 VA or 30 W (24 VA or 6 W for the connector output)

Minimum load: 5 V DC @ 10m A

Mechanical life: 5 × 10⁷ cycles

• Single Alarm

Front terminals

	5 – 6	5 – 7
Energized	ON	OFF
De-energized (or power OFF)	OFF	ON

Rear connector

OUTPUT CODE	POWER ON		POWER OFF
	IN < SET	IN > SET	
1	OFF	ON	OFF
2	OFF	ON	ON
3	ON	OFF	OFF
4	ON	OFF	ON

• Dual Alarm (front terminals)

OUTPUT SUFFIX CODE	POWER ON				POWER OFF	
	IN < SET		IN > SET		5 – 6	7 – 8
	5 – 6	7 – 8	5 – 6	7 – 8		
5	ON	OFF	OFF	ON	OFF	OFF
6	OFF	ON	ON	OFF	OFF	OFF

Shades indicates that the relay is energized.

INSTALLATION

Power consumption

•DC: Approx. 80 mA

Operating temperature: -5 to +55°C (23 to 131°F)

Operating humidity: 30 to 90 %RH (non-condensing)

Mounting: Standard Rack 18BXx or 18KBXx

Weight: 150 g (0.33 lb)

PERFORMANCE in percentage of span

Trip point repeatability: ±0.1 %

Cold junction compensation error

(at 20°C ±10°C or 68°F ±18°F)

K, E, J, T, N: ±0.5°C or ±0.9°F

S, R, PR: ±1°C or ±1.8°F

Temp. coefficient: ±0.015 %/°C (±0.008 %/°F)



EXTERNAL VIEW

■ SINGLE ALARM

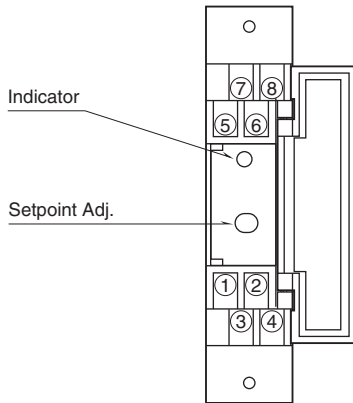

■ DUAL ALARM

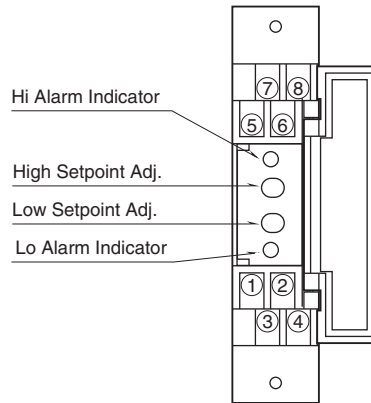

DIMENSIONS unit: mm (inch)

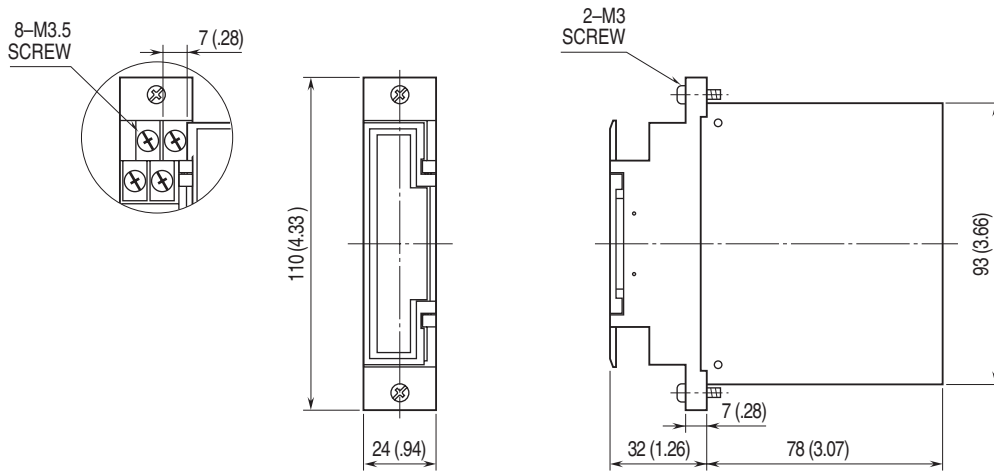

TERMINAL ASSIGNMENTS

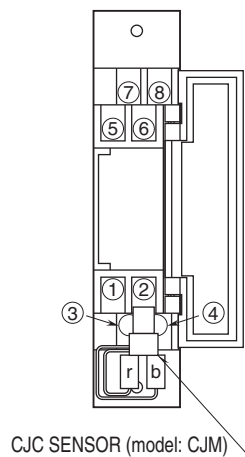

SCHEMATIC CIRCUITRY & CONNECTION DIAGRAM

■ SINGLE ALARM

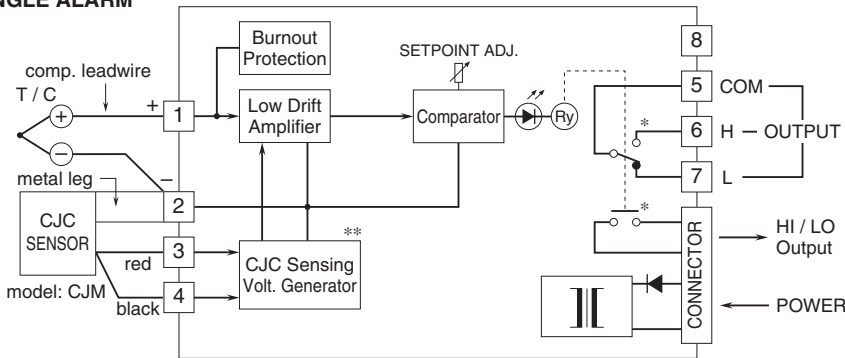

■ Relay Protection

•AC Powered

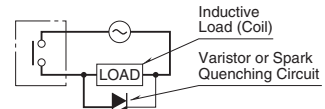

•DC Powered

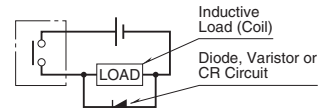

■ DUAL ALARM

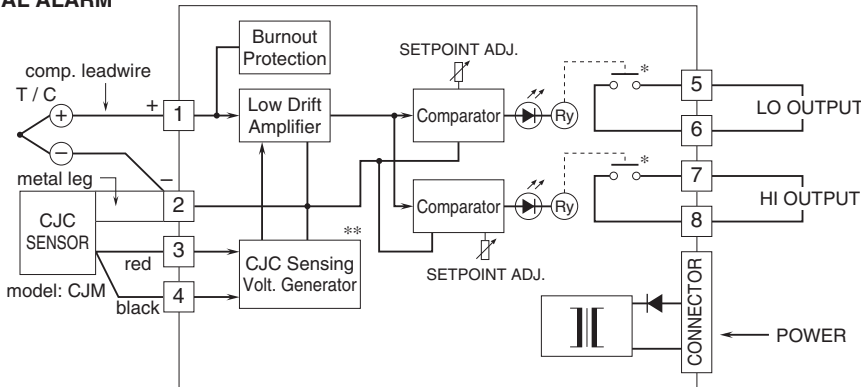

* Relay status is determined by output codes.

**Deleted with B thermocouple



Specifications are subject to change without notice.