

Rack-mounted DCS Signal Conditioners 18-RACK

DC ALARM

Functions & Features

- Providing relay contact closures at preset DC input levels
- Single or dual (Hi/Lo) trip
- Frontaccessed screwdriver setpoint adjustments
- Enclosed relays

Typical Applications

- Annunciator
- Various alarm applications

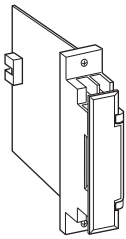

MODEL: 18AS2-[1][2]-R

ORDERING INFORMATION

- Code number: 18AS2-[1][2]-R
Specify a code from below for each [1] and [2].
(e.g. 18AS2-62-R)
 - Special input range (For code 0)
- Use Ordering Information Sheet (No. ESU-1033) to specify alarm output code 0 specifications.

[1] INPUT

Current

- A: 4 - 20 mA DC (Input resistance 250 Ω)
- D: 0 - 20 mA DC (Input resistance 50 Ω)
- G: 0 - 1 mA DC (Input resistance 1000 Ω)
- H: 10 - 50 mA DC (Input resistance 100 Ω)

Voltage

- 3: 0 - 1 V DC (Input resistance 1 MΩ min.)
- 4: 0 - 10 V DC (Input resistance 1 MΩ min.)
- 5: 0 - 5 V DC (Input resistance 1 MΩ min.)
- 6: 1 - 5 V DC (Input resistance 1 MΩ min.)
- 0: Specify voltage (See INPUT SPECIFICATIONS)

[2] ALARM OUTPUT

- 1: Hi (coil energized at alarm)
- 2: Hi (coil de-energized at alarm)
- 3: Lo (coil energized at alarm)
- 4: Lo (coil de-energized at alarm)
- 5: Hi/Lo; N.O., OFF in power failure

- (connector output not available)
- 6: Hi/Lo; N.C., OFF in power failure
(connector output not available)
- 0: Specify

POWER INPUT

DC Power

- R: 24 V DC
(Operational voltage range 24 V ±10 %, ripple 10 %p-p max.)

GENERAL SPECIFICATIONS

Construction: Rack-mounted; terminal access via screw terminals on the front and connector on the rear; terminal cover provided

Connection

- Input:** M3.5 screw terminals (torque 0.8 N·m)
- Alarm output:** M3.5 screw terminals (torque 0.8 N·m) and connector

Power input: supplied from connector

Screw terminal: Nickel-plated steel

Isolation: Input to output to power

Relay: Enclosed

Setpoint adjustments: Multi-turn screwdriver adjustments (front); -5 - +105 % independently

Hysteresis (deadband): Approx. 1 %

Front LEDs: Red light turns on when the coil is energized.

INPUT SPECIFICATIONS

- **DC Current:** Input resistor incorporated
- **DC Voltage:** 0 - 300 V DC
- Minimum span:** 1 V
- Offset:** Max. 1.5 times span
- Input resistance:** ≥ 1 MΩ



OUTPUT SPECIFICATIONS

Output: Enclosed SPST and SPDT relays

Rating:

30 V DC @ 1 A (resistive load)

0.2 A for the connector output

Maximum switching voltage: 30 V DC

Max. switching power: 30 W (6 W for the connector output)

Minimum load: 5 V DC @ 10m A

Mechanical life: 5 × 10⁷ cycles

• **Single Alarm**

Front terminals

	5 – 6	5 – 7
Energized	ON	OFF
De-energized (or power OFF)	OFF	ON

Rear connector

OUTPUT CODE	POWER ON		POWER OFF
	IN < SET	IN > SET	
1	OFF	ON	OFF
2	OFF	ON	ON
3	ON	OFF	OFF
4	ON	OFF	ON

• **Dual Alarm (front terminals)**

OUTPUT SUFFIX CODE	POWER ON				POWER OFF	
	IN < SET		IN > SET		5 – 6	7 – 8
	5 – 6	7 – 8	5 – 6	7 – 8		
5	ON	OFF	OFF	ON	OFF	OFF
6	OFF	ON	ON	OFF	OFF	OFF

Shades indicates that the relay is energized.

INSTALLATION

Power consumption

•DC: Approx. 80 mA

Operating temperature: -5 to +55°C (23 to 131°F)

Operating humidity: 30 to 90 %RH (non-condensing)

Mounting: Standard Rack 18BXx or 18KBXx

Weight: 150 g (0.33 lb)

PERFORMANCE in percentage of span

Trip point repeatability: ±0.1 %

Temp. coefficient: ±0.015 %/°C (±0.008 %/°F)

Response time: ≤ 0.5 sec. (0 - 100 % at 90 % setpoint)

Line voltage effect: ±0.1 % over voltage range

Insulation resistance: ≥ 100 MΩ with 500 V DC

Dielectric strength: 1500 V AC @ 1 minute

(input to output or power)

500 V AC @ 1 minute (output to power)

1500 V AC @ 1 minute (input or output or power to ground)



EXTERNAL VIEW

■ SINGLE ALARM

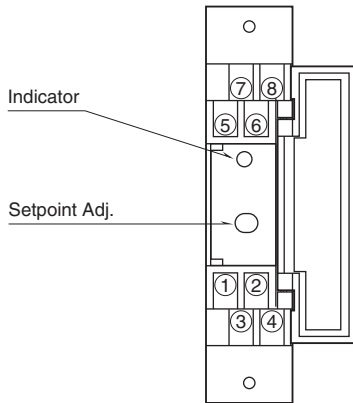

■ DUAL ALARM

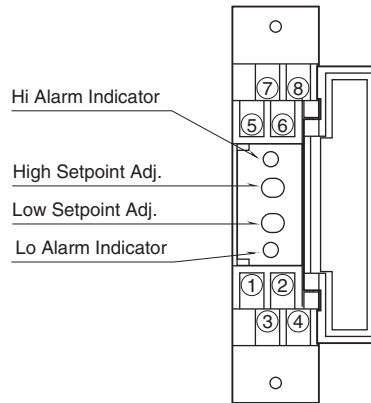

DIMENSIONS unit: mm (inch)

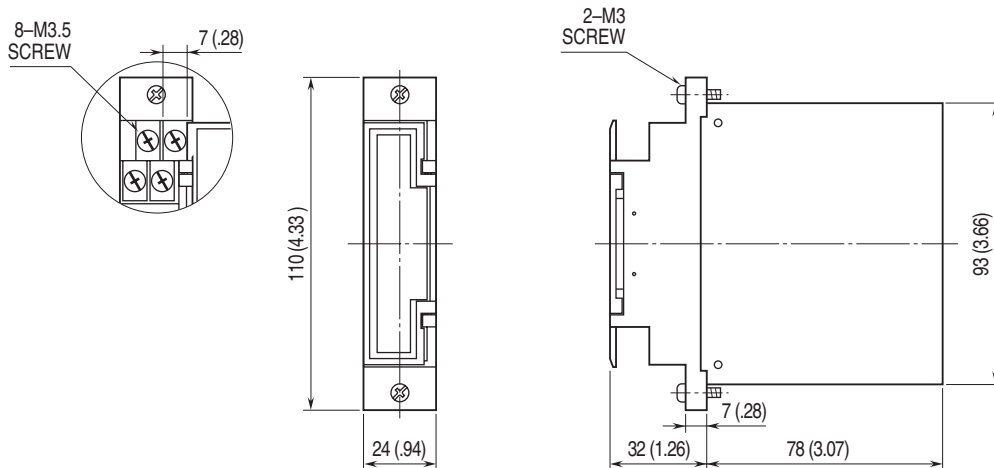

TERMINAL ASSIGNMENTS

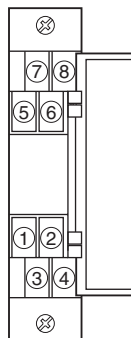

SCHEMATIC CIRCUITRY & CONNECTION DIAGRAM

SINGLE ALARM

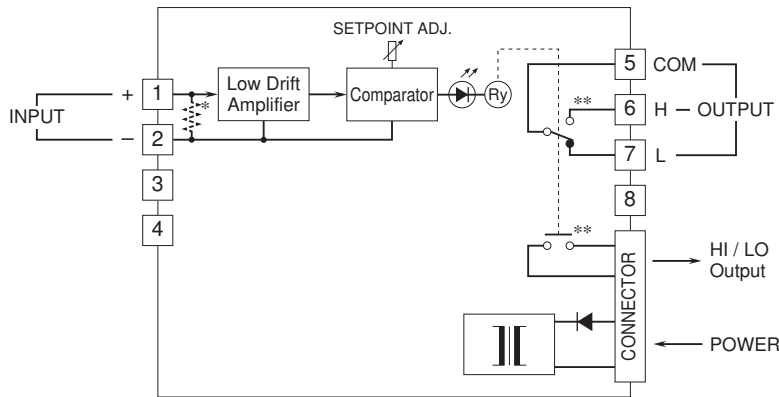

Relay Protection • AC Powered

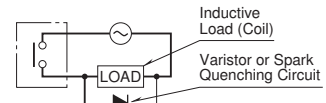

• DC Powered

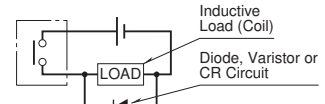

DUAL ALARM

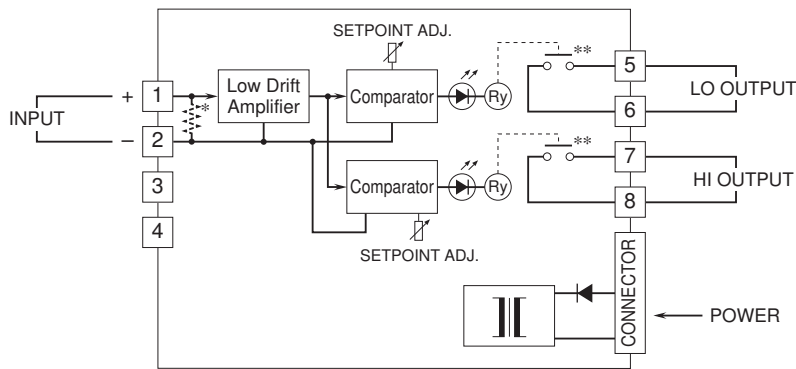

* Input shunt resistor incorporated for current input.

**Relay status is determined by output codes.



Specifications are subject to change without notice.