

High-density Signal Conditioners 10-RACK

RTD TRANSMITTER

Functions & Features

- Accepting direct input from an RTD and providing two standard process signals
- Linearization
- Burnout protection
- Optional second channel output available at the front terminals and at the Standard Rack connector

Typical Applications

- Converting into standard signals
- Power plant

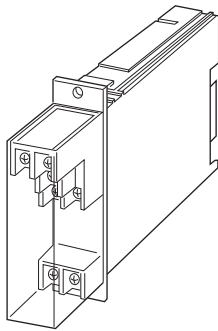

MODEL: 10RS-[1][2][3]-R[4]

ORDERING INFORMATION

- Code number: 10RS-[1][2][3]-R[4]
- Specify a code from below for each [1] through [4]. (e.g. 10RS-1A6-R/BL/Q)
- Temperature range (e.g. 0 – 500 °C)
- Specify the specification for option code /Q (e.g. /C01)

[1] INPUT RTD (2- or 3-wire)

- 1:** JPt 100 (JIS'89)
(Usable range: -200 to +500°C, -328 to +932°F; min.span: 30°C, 54°F)
- 3:** Pt 100 (JIS'89)
(Usable range: -200 to +650°C, -328 to +1202°F; min.span: 30°C, 54°F)
- 4:** Pt 100 (JIS'97, IEC)
(Usable range: -200 to +650°C, -328 to +1202°F; min.span: 30°C, 54°F)
- 5:** Pt 50 Ω (JIS'81)
(Usable range: -200 to +500°C, -328 to +932°F; min.span: 60°C, 108°F)
- 6:** Ni 508.4 Ω
(Usable range: -50 to +200°C, -58 to +392°F; min.span: 20°C, 36°F)
- 0:** Specify
Note: Consult M-System for 2-wire RTD

[2] OUTPUT 1

Current

- A:** 4 – 20 mA DC (Load resistance 600 Ω max.)
B: 2 – 10 mA DC (Load resistance 1200 Ω max.)
C: 1 – 5 mA DC (Load resistance 2400 Ω max.)
D: 0 – 20 mA DC (Load resistance 600 Ω max.)
E: 0 – 16 mA DC (Load resistance 750 Ω max.)
F: 0 – 10 mA DC (Load resistance 1200 Ω max.)
G: 0 – 1 mA DC (Load resistance 12 kΩ max.)

Voltage

- 1:** 0 – 10 mV DC (Load resistance 10 kΩ min.)
2: 0 – 100 mV DC (Load resistance 100 kΩ min.)
3: 0 – 1 V DC (Load resistance 100 Ω min.)
4: 0 – 10 V DC (Load resistance 1000 Ω min.)
5: 0 – 5 V DC (Load resistance 500 Ω min.)
6: 1 – 5 V DC (Load resistance 500 Ω min.)

[3] OUTPUT 2

0: None

Voltage

- 6:** 1 – 5 V DC (Load resistance 5000 Ω min.)

POWER INPUT

DC Power

R: 24 V DC
(Operational voltage range 24 V ±10 %, ripple 10 %p-p max.)

[4] OPTIONS (multiple selections)

Burnout

blank: Upscale burnout
/BL: Downscale burnout

Other Options

blank: none
/Q: Option other than the above (specify the specification)

SPECIFICATIONS OF OPTION: Q

COATING (For the detail, refer to M-System's web site.)

/C01: Silicone coating
/C02: Polyurethane coating
/C03: Rubber coating

GENERAL SPECIFICATIONS

Construction: Rack-mounted; terminal access via screw terminals at the front and via card-edge connector at the rear; terminal cover provided

Connection

Input: M3.5 screw terminals (torque 0.8 N·m)
Output: Card-edge connector and M3.5 screw terminals (torque 0.8 N·m)
Power input: Supplied from card-edge connector



Screw terminal: Nickel-plated steel
Housing material: Flame-resistant resin (black)
Isolation: Input to output 1 to output 2 to power
Overrange output: Approx. -10 to +120 % at 1 - 5 V
Zero adjustment: -5 to +5 % (front)
Span adjustment: 95 to 105 % (front)
Linearization: Standard

INPUT SPECIFICATIONS

Maximum leadwire resistance: 20 Ω per wire (3-wire)
Sensing current: 2 mA

INSTALLATION

Current consumption: Approx. 35 mA with voltage output 1
 Approx. 55 mA with current output 1
Operating temperature: -5 to +55°C (23 to 131°F)
Operating humidity: 30 to 90 %RH (non-condensing)
Mounting: Standard Rack 10BXx
Weight: 200 g (0.44 lb)

PERFORMANCE in percentage of span

Accuracy: ± 0.2 %
Temp. coefficient: ± 0.015 %/°C (± 0.008 %/°F)
Response time: ≤ 0.5 sec. (0 - 90 %)
Burnout response: ≤ 10 sec.
Line voltage effect: ± 0.1 % over voltage range
Insulation resistance: ≥ 100 M Ω with 500 V DC
Dielectric strength: 500 V AC @ 1 minute
 (input to output 1 to output 2 to power)
 1500 V AC @ 1 minute (input or output or power to ground)

EXTERNAL DIMENSIONS & TERMINAL ASSIGNMENTS unit: mm (inch)

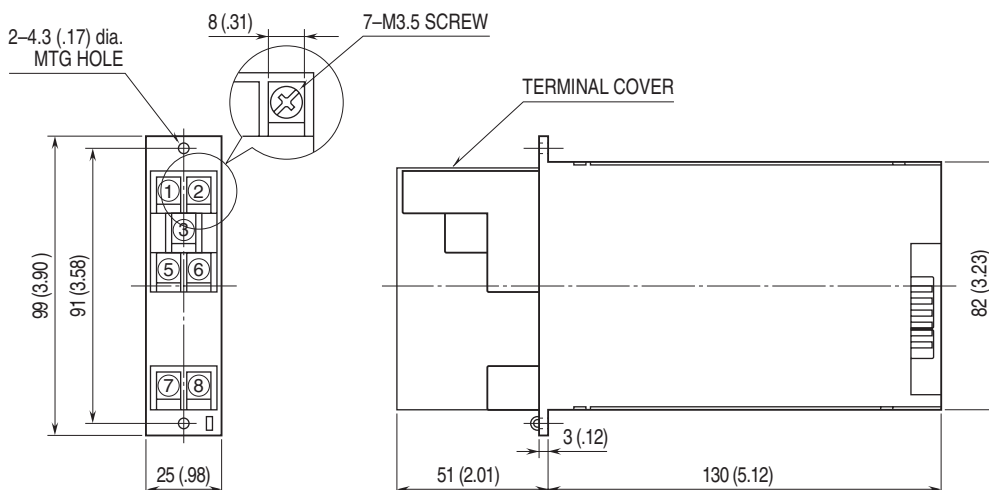

SCHEMATIC CIRCUITRY & CONNECTION DIAGRAM

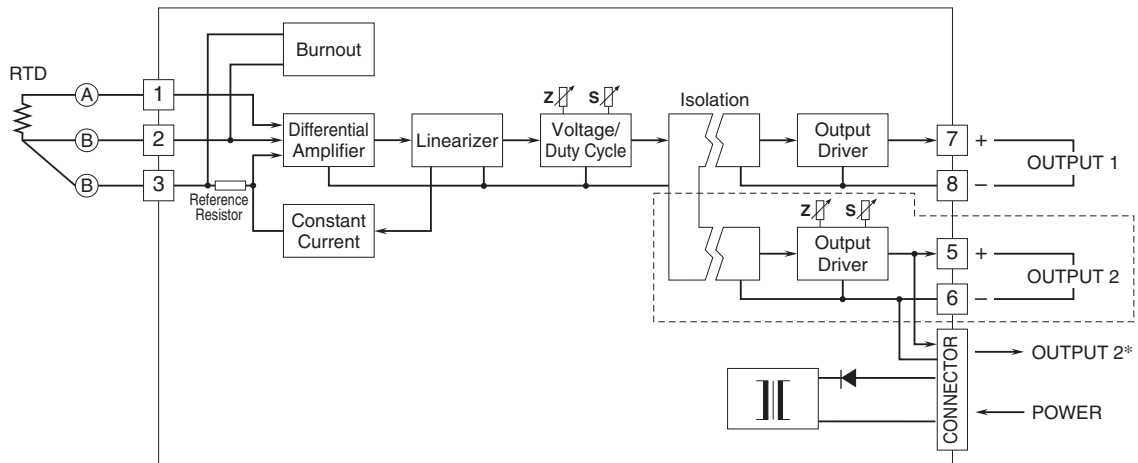

*1 output type has the output 1 connected to the card-edge connector in parallel.
 Remark 1) The section enclosed by broken line is only for 2nd output channel.



Specifications are subject to change without notice.

