

High-density Signal Conditioners 10-RACK

(Operational voltage range 24 V \pm 10 %, ripple 10 %p-p max.)

PULSE SCALER

Functions & Features

- Converting pulse rate into convenient engineering unit for display on a totalizing counter or meter

Typical Applications

- Positive displacement flowmeters and turbine flowmeters
- Magnetic tachometers

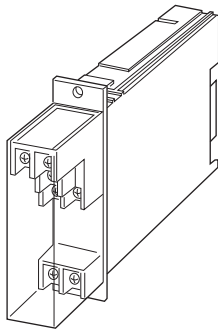

MODEL: 10PR-[1][2]0-R[3]

ORDERING INFORMATION

- Code number: 10PR-[1][2]0-R[3]
- Specify a code from below for each [1] through [3]. (e.g. 10PR-110-R/Q)
- Input frequency range (e.g. 0 - 356.7 Hz)
- Output frequency range (e.g. 0 - 1.00 Hz)
- Specify the specification for option code /Q (e.g. /C01)

[1] INPUT

- 1: Dry contact (max. 100 kHz)
- 2: Voltage pulse (max. 100 kHz)

[2] OUTPUT 1

- 1: Open collector (max. frequency 20 kHz)
- 2: 5 V pulse (max. frequency 20 kHz)
- 3: Relay contact (max. frequency 2 Hz)
- 4: 24 V pulse (max. frequency 20 Hz)

OUTPUT 2

0: None

POWER INPUT

DC Power

R: 24 V DC

[3] OPTIONS

blank: none

/Q: With options (specify the specification)

SPECIFICATIONS OF OPTION: Q

COATING (For the detail, refer to M-System's web site.)

/C01: Silicone coating

/C02: Polyurethane coating

/C03: Rubber coating

CAUTION

- 1) This unit's output waveform is not uniform due to its scaling method.
- 2) Use input relays which do not cause chattering (e.g. mercury relays). Other relays could be used only with a CR filter, for 10 Hz at maximum.
- 3) Use M-System's Model M2PRU instead of this unit in conjunction with the pulse output from M-System's power transducers.

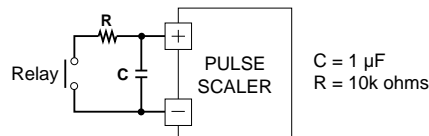

GENERAL SPECIFICATIONS

Construction: Rack-mounted; terminal access via screw terminals at the front and via card-edge connector at the rear; terminal cover provided

Connection

Input: M3.5 screw terminals (torque 0.8 N·m)

Output: Card-edge connector and M3.5 screw terminals (torque 0.8 N·m)

Power input: Supplied from card-edge connector

Screw terminal: Nickel-plated steel

Housing material: Flame-resistant resin (black)

Isolation: Input to output to power

Input pulse sensing: Capacitor coupled; detecting pulse rise

Sensitivity adjustment: Single-turn screwdriver adjustment (front); 25 mVp-p - 5 Vp-p

Scaling factor: $0.9999 \times 10^0 - 0.0001 \times 10^{-6}$

INPUT SPECIFICATIONS

■ **Dry Contact:** Mechanical contact or open collector

Max. frequency: 100 kHz

Pulse width time requirement: 5 µsec. min. (20 msec. min. for frequencies \leq 10 Hz)

Sensing: Approx. 7.5 V DC @ 1 mA



ON/OFF level: $\leq 20\text{ k}\Omega$ for ON, $\geq 100\text{ k}\Omega$ for OFF

■ **Voltage Pulse:** Square or sine waveforms*

Max. frequency: 100 kHz

Pulse width time requirement: 5 $\mu\text{sec.}$ min. (20 msec. min. for frequencies $\leq 10\text{ Hz}$)

Input amplitude: 25 mVp-p - 50 Vp-p

Minimum amplitude requirement

• **With duty ratio 50 % $\pm 10\%$**

(frequency: amplitude)

0 - 2 kHz: 25 mVp-p

0 - 20 kHz: 50 mVp-p

0 - 40 kHz: 1 Vp-p

0 - 100 kHz: 5 Vp-p

• **With duty ratio other than 50 % $\pm 10\%$**

(pulse width: amplitude)

5 $\mu\text{sec.}$: 5 Vp-p

10 $\mu\text{sec.}$: 3.5 Vp-p

50 $\mu\text{sec.}$: 2 Vp-p

100 $\mu\text{sec.}$: 1 Vp-p

500 $\mu\text{sec.}$: 0.5 Vp-p

Input impedance: 100 k Ω minimum

*Voltage pulse examples

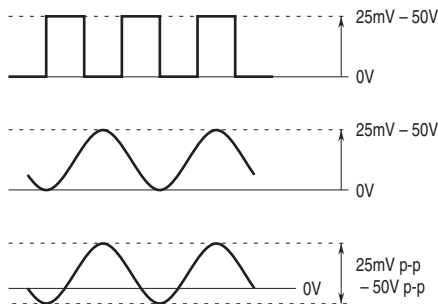

OUTPUT SPECIFICATIONS

■ **Open Collector:** 50 V DC @ 50 mA (resistive load)

Frequency range: 0 - 20 kHz

ON pulse width: Approx. 30 $\mu\text{sec.}$

Saturation voltage: 0.6 V DC

■ **Relay Contact:** 120 V AC @ 200 mA ($\cos \phi = 1$)

240 V AC @ 100 mA ($\cos \phi = 1$)

24 V DC @ 200 mA (resistive load)

Maximum switching voltage: 240 V AC or 30 V DC

Maximum switching power: 24 VA or 4.8 W

Minimum load: 5 V DC @ 10 mA

Frequency range: 0 - 2 Hz

ON pulse width: Approx. 30 msec.

Relay life: $\geq 5 \times 10^7$ cycles (mechanical)

$\geq 10^5$ cycles (electrical)

■ **5 V Pulse**

Frequency range: 0 - 20 kHz

Low pulse width: Approx. 30 $\mu\text{sec.}$

High level: 5 V $\pm 10\%$

Low level: $\leq 0.5\text{ V}$

Load resistance: 600 Ω minimum

■ **24 V Pulse**

Frequency range: 0 - 20 Hz

High pulse width: Approx. 30 msec.

High level: 24 V $\pm 10\%$

Low level: $\leq 0.5\text{ V}$

Load current: 30 mA max.

Load resistance: 800 Ω minimum

INSTALLATION

Current consumption: Approx. 80 mA

Operating temperature: -5 to +55°C (23 to 131°F)

Operating humidity: 30 to 90 %RH (non-condensing)

Mounting: Standard Rack 10BXx

Weight: 200 g (0.44 lb)

PERFORMANCE

Insulation resistance: $\geq 100\text{ M}\Omega$ with 500 V DC

Dielectric strength: 500 V AC @ 1 minute

(input to output to power)

1500 V AC @ 1 minute (input or output or power to ground)



EXTERNAL VIEW

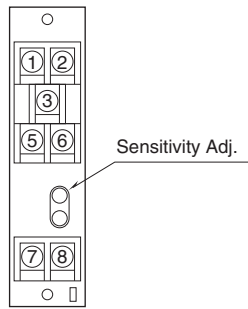

EXTERNAL DIMENSIONS & TERMINAL ASSIGNMENTS unit: mm (inch)

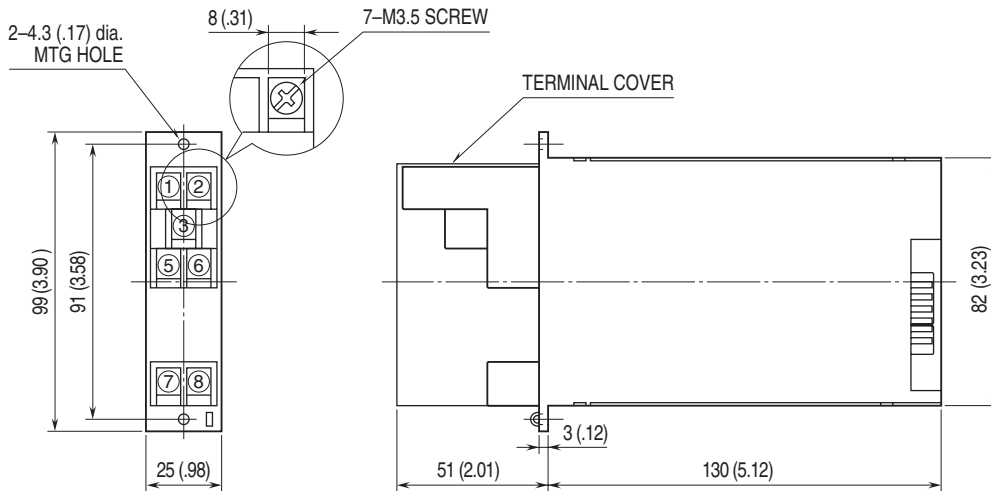

SCHEMATIC CIRCUITRY & CONNECTION DIAGRAM

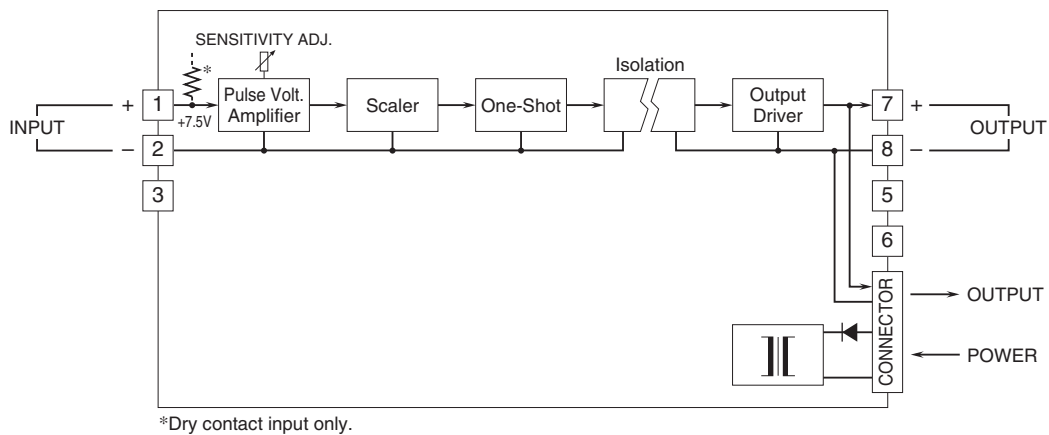

Specifications are subject to change without notice.

