

## High-density Signal Conditioners 10-RACK

### WATT TRANSDUCER

#### Functions & Features

- Providing a DC output signal in proportion to AC active power
- Measuring bidirectional power flow
- DC output containing little ripple is ideal for computer input
- "Time division multiplication" method accepts distorted waveforms
- Isolation up to 2000 V AC (input circuit)

#### Typical Applications

- Centralized monitoring and control of power management system in a manufacturing facility or building
- SCR - Silicon Controlled Rectifier

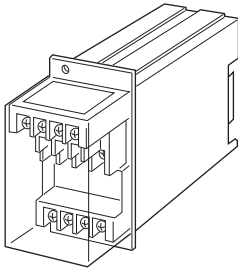

### MODEL: 10EWT-[1][2][3]-R[4]

#### ORDERING INFORMATION

- Code number: 10EWT-[1][2][3]-R[4]
- Specify a code from below for each [1] through [4]. (e.g. 10EWT-11A-R/Q)
- Calibration range (e.g. 0 - 1000 W)
- VT ratio, CT ratio (e.g. VT 3300/110 V, CT 250/5 A)
- Special output range (For codes Z & 0)
- Specify the specification for option code /Q (e.g. /C01)

#### [1] CONFIGURATION

- 1: 3-phase / 3-wire
- 2: Single-phase / 2-wire
- 3: Single-phase / 3-wire
- 4: 3-phase / 4-wire

#### [2] INPUT (unbalanced load)

- 1: 110 V / 5 A AC
- 2: 110 V / 1 A AC

- 3: 220 V / 1 A AC
  - 4: 220 V / 5 A AC
  - 5: 220 V / 380 V / 1 A AC (3-phase / 4-wire)
  - 6: 220 V / 380 V / 5 A AC (3-phase / 4-wire)
  - 7: 110 V / 190 V / 1 A AC (3-phase / 4-wire)
  - 8: 110 V / 190 V / 5 A AC (3-phase / 4-wire)
  - A: 100 V / 200 V / 1 A AC (single-phase / 3-wire)
  - B: 100 V / 200 V / 5 A AC (single-phase / 3-wire)
- (220 V in code 5 and 6, and 110 V in code 7 and 8 are phase voltage)

#### [3] OUTPUT

##### Current

- A: 4 - 20 mA DC (Load resistance 600 Ω max.)
- B: 2 - 10 mA DC (Load resistance 1200 Ω max.)
- C: 1 - 5 mA DC (Load resistance 2400 Ω max.)
- D: 0 - 20 mA DC (Load resistance 600 Ω max.)
- E: 0 - 16 mA DC (Load resistance 750 Ω max.)
- F: 0 - 10 mA DC (Load resistance 1200 Ω max.)
- G: 0 - 1 mA DC (Load resistance 12 kΩ max.)
- J: 0 - 5 mA DC (Load resistance 2400 Ω max.)
- GW: -1 - +1 mA DC (Load resistance 10 kΩ max.)
- Z: Specify current (See OUTPUT SPECIFICATIONS)

##### Voltage

- 1: 0 - 10 mV DC (Load resistance 10 kΩ min.)
- 2: 0 - 100 mV DC (Load resistance 100 kΩ min.)
- 3: 0 - 1 V DC (Load resistance 1000 Ω min.)
- 4: 0 - 10 V DC (Load resistance 10 kΩ min.)
- 5: 0 - 5 V DC (Load resistance 5000 Ω min.)
- 6: 1 - 5 V DC (Load resistance 5000 Ω min.)
- 1W: -10 - +10 mV DC (Load resistance 10 kΩ min.)
- 2W: -100 - +100 mV DC (Load resistance 100 kΩ min.)
- 3W: -1 - +1 V DC (Load resistance 1000 Ω min.)
- 4W: -10 - +10 V DC (Load resistance 10 kΩ min.)
- 5W: -5 - +5 V DC (Load resistance 5000 Ω min.)
- 0: Specify voltage (See OUTPUT SPECIFICATIONS)

#### POWER INPUT

##### DC Power

- R: 24 V DC
- (Operational voltage range 24 V ±10 %, ripple 10 %p-p max.)

#### [4] OPTIONS

- blank: none
- /Q: With options (specify the specification)

#### SPECIFICATIONS OF OPTION: Q

- COATING (For the detail, refer to M-System's web site.)
- /C01: Silicone coating
- /C02: Polyurethane coating



/C03: Rubber coating

## GENERAL SPECIFICATIONS

**Construction:** Rack-mounted; terminal access via screw terminals at the front and via card-edge connector at the rear; terminal cover provided

### Connection

**Input:** M3.5 screw terminals (torque 0.8 N·m)

**Output:** Card-edge connector and M3.5 screw terminals (torque 0.8 N·m)

**Power input:** Supplied from card-edge connector

**Screw terminal:** Nickel-plated steel

**Housing material:** Flame-resistant resin (black)

**Isolation:** Voltage input to current input to output to power

**Overrange output:** Approx. -10 to +120 % at 1 - 5 V

**Zero adjustment:** -5 to +5 % (front)

**Span adjustment:** 95 to 105 % (front)

## INPUT SPECIFICATIONS

**Frequency:** 50 or 60 Hz

### • Current Input

**Operational range:** 0 - 120 % of rating

**Overload capacity:** 1000 % of rating for 3 sec., 200 % for 10 sec., 120 % continuous

### • Voltage Input

**Operational range:** 0 - 120 % of rating

**Overload capacity:** 150 % of rating for 10 sec., 120 % continuous

### ■ How To Determine Wattage Range

Calibration Range [W] = Measuring Wattage ÷ ((VT Ratio) × (CT Ratio))

Check that the required calibration range is within the available range in the table. Specify this range when ordering.

[example]

3-phase / 3-wire, measuring wattage 750 kW,

VT 3300/110 V, CT 250/5 A

$750 \times 10^3 [W] \div ((3300 \div 110) \times (250 \div 5)) = 0 - 500 [W]$

### • 3-phase / 3-wire

INPUT		AVAILABLE RANGE	BURDEN (VA)	
	STD.RANGE		VOLT.	CURR.
110V/1A	±200W	±100 - ±240W	0.2 /phase	0.1/phase
110V/5A	±1000W			0.5/phase
220V/1A	±400W	±200 - ±480W	0.4 /phase	0.1/phase
220V/5A	±2000W			0.5/phase

### • Single-phase / 2-wire

INPUT		AVAILABLE RANGE	BURDEN (VA)	
	STD.RANGE		VOLT.	CURR.
110V/1A	±100W	±50 - ±120W	0.2	0.1
110V/5A	±500W			0.5
220V/1A	±200W	±100 - ±240W	0.4	0.1
220V/5A	±1000W			0.5

### • Single-phase / 3-wire

INPUT		AVAILABLE RANGE	BURDEN (VA)	
	STD.RANGE		VOLT.	CURR.
100/200V/1A*	±200W	±100 - ±240W	0.2 /phase	0.1/phase
100/200V/5A*	±1000W			0.5/phase

\*100V indicates phase voltage, while 200V indicates line voltage except between ground.

### • 3-phase / 4-wire

INPUT		AVAILABLE RANGE	BURDEN (VA)	
	STD.RANGE		VOLT.	CURR.
$\frac{110V}{\sqrt{3}}$ /1A	±200W	±100 - ±240W	0.1 /phase	0.1/phase
$\frac{110V}{\sqrt{3}}$ /5A	±1000W			0.5/phase
$\frac{190V}{\sqrt{3}}$ /1A	±350W	±175 - ±420W	0.2 /phase	0.1/phase
$\frac{190V}{\sqrt{3}}$ /5A	±1750W			0.5/phase
$\frac{220V}{\sqrt{3}}$ /1A	±400W	±200 - ±480W	0.3 /phase	0.1/phase
$\frac{220V}{\sqrt{3}}$ /5A	±2000W			0.5/phase
$\frac{380V}{\sqrt{3}}$ /1A	±700W	±350 - ±840W	0.4 /phase	0.1/phase
$\frac{380V}{\sqrt{3}}$ /5A	±3500W			0.5/phase



## OUTPUT SPECIFICATIONS

### ■ DC Output

•DC Current: 0 - 20 mA DC and  $\pm 1$  mA

Minimum span: 1 mA

Offset:  $\leq 1.5$  times span

Load resistance: Output drive 12 V max.; 10 V for  $[\pm]$  output

### ■ DC Voltage: -10 - +12 V DC

Minimum span: 5 mV

Offset: Max. 1.5 times span

Load resistance: Output drive 1 mA max. at  $\geq 0.5$  V

### ■ OPERATION DIAGRAM (example)

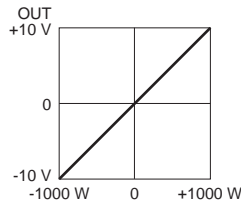
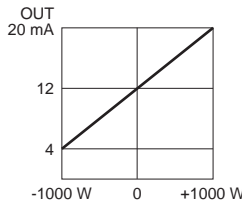
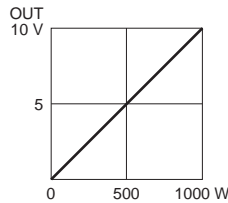
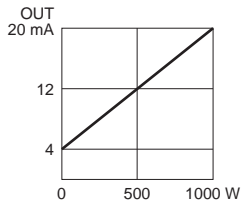

## INSTALLATION

Current consumption: Approx. 80 mA

Operating temperature: -5 to +55°C (23 to 131°F)

Operating humidity: 30 to 90 %RH (non-condensing)

Mounting: Standard Rack 10BXx

Weight: 450 g (0.99 lb)

## PERFORMANCE in percentage of span

Accuracy:  $\pm 0.5$  %

Temp. coefficient:  $\pm 0.05$  %/°C ( $\pm 0.03$  %/°F)

Response time:  $\leq 1$  sec. (0 - 90 %)

Ripple: 0.5 %p-p max. (50/60 Hz)

Line voltage effect:  $\pm 0.1$  % over voltage range

Insulation resistance:  $\geq 100$  M $\Omega$  with 500 V DC

Dielectric strength: 2000 V AC @ 1 minute (voltage input to

current input to output or power to ground)

500 V AC @ 1 minute (output to power)



## CONNECTION DIAGRAM

### ■ 3-PHASE/3-WIRE

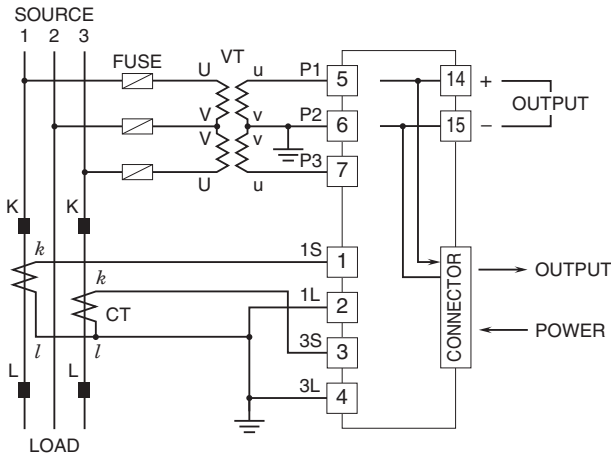

### ■ SINGLE-PHASE/2-WIRE

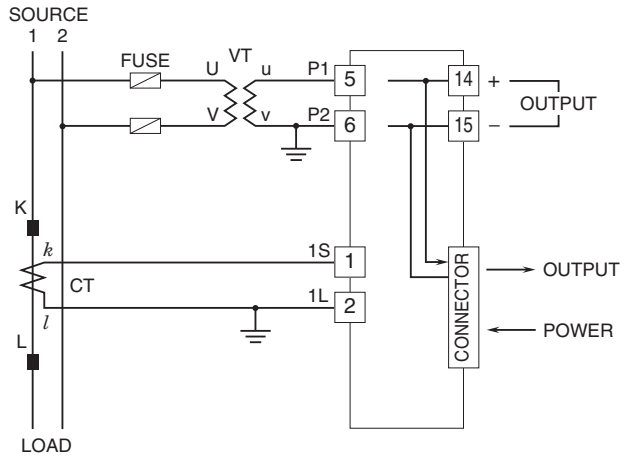

### ■ SINGLE-PHASE/3-WIRE

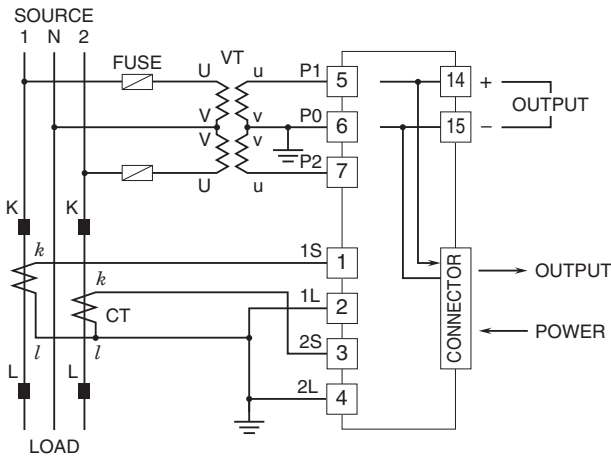

### ■ 3-PHASE/4-WIRE

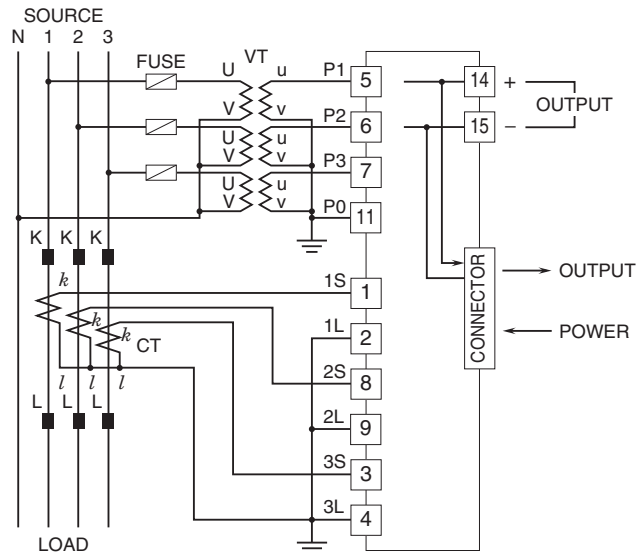

## EXTERNAL DIMENSIONS & TERMINAL ASSIGNMENTS unit: mm (inch)

Terminals 8 through 11 are installed only for 3-phase/4-wire model.

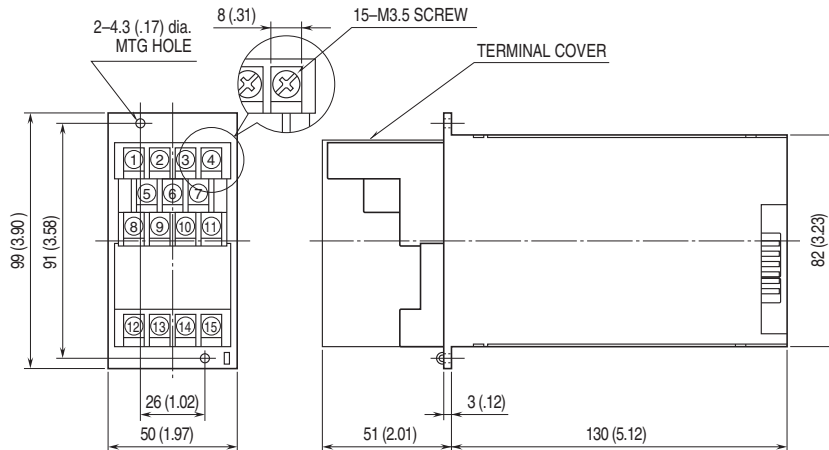



Specifications are subject to change without notice.

