

High-density Signal Conditioners 10-RACK

VAR TRANSDUCER

Functions & Features

- Providing a DC output signal in proportion to AC reactive power
- DC output containing little ripple is ideal for computer input
- "Time division multiplication" method accepts distorted waveforms
- Isolation up to 2000 V AC (input circuit)

Typical Applications

- Centralized monitoring and control of power management system in a manufacturing facility or building

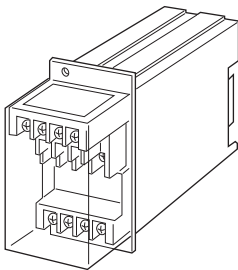

MODEL: 10ERP-[1][2][3][4]-R[5]

ORDERING INFORMATION

- Code number: 10ERP-[1][2][3][4]-R[5]
Specify a code from below for each [1] through [5].
(e.g. 10ERP-11PA-R/Q)
- Calibration range (e.g. lag 1000 - lead 1000 var)
- VT ratio, CT ratio (e.g. VT 3300/110 V, CT 250/5 A)
- Special output range (For codes Z & 0)
- Specify the specification for option code /Q
(e.g. /C01)

[1] CONFIGURATION

- 1: 3-phase / 3-wire
- 4: 3-phase / 4-wire

[2] INPUT (unbalanced load)

(Voltage must be balanced.)

- 1: 110 V / 5 A AC
- 2: 110 V / 1 A AC
- 3: 220 V / 1 A AC
- 4: 220 V / 5 A AC
- 5: 220 V / 380 V / 1 A AC (3-phase / 4-wire)

- 6: 220 V / 380 V / 5 A AC (3-phase / 4-wire)
 - 7: 110 V / 190 V / 1 A AC (3-phase / 4-wire)
 - 8: 110 V / 190 V / 5 A AC (3-phase / 4-wire)
- (220 V in code 5 and 6, and 110 V in code 7 and 8 are phase voltage)

[3] OUTPUT SIGNAL POLARITY

- P: Negative in lag, positive in lead
- M: Negative in lead, positive in lag

[4] OUTPUT

Current

- A: 4 - 20 mA DC (Load resistance 600 Ω max.)
- B: 2 - 10 mA DC (Load resistance 1200 Ω max.)
- C: 1 - 5 mA DC (Load resistance 2400 Ω max.)
- D: 0 - 20 mA DC (Load resistance 600 Ω max.)
- E: 0 - 16 mA DC (Load resistance 750 Ω max.)
- F: 0 - 10 mA DC (Load resistance 1200 Ω max.)
- G: 0 - 1 mA DC (Load resistance 12 kΩ max.)
- GW: -1 - +1 mA DC (Load resistance 10 kΩ max.)
- Z: Specify current (See OUTPUT SPECIFICATIONS)

Voltage

- 1: 0 - 10 mV DC (Load resistance 10 kΩ min.)
- 2: 0 - 100 mV DC (Load resistance 100 kΩ min.)
- 3: 0 - 1 V DC (Load resistance 1000 Ω min.)
- 4: 0 - 10 V DC (Load resistance 10 kΩ min.)
- 5: 0 - 5 V DC (Load resistance 5000 Ω min.)
- 6: 1 - 5 V DC (Load resistance 5000 Ω min.)
- 1W: -10 - +10 mV DC (Load resistance 10 kΩ min.)
- 2W: -100 - +100 mV DC (Load resistance 100 kΩ min.)
- 3W: -1 - +1 V DC (Load resistance 1000 Ω min.)
- 4W: -10 - +10 V DC (Load resistance 10 kΩ min.)
- 5W: -5 - +5 V DC (Load resistance 5000 Ω min.)
- 0: Specify voltage (See OUTPUT SPECIFICATIONS)

POWER INPUT

DC Power

- R: 24 V DC
(Operational voltage range 24 V ±10 %, ripple 10 %p-p max.)

[5] OPTIONS

- blank: none
- /Q: With options (specify the specification)

SPECIFICATIONS OF OPTION: Q

COATING (For the detail, refer to M-System's web site.)

- /C01: Silicone coating
- /C02: Polyurethane coating
- /C03: Rubber coating



GENERAL SPECIFICATIONS

Construction: Rack-mounted; terminal access via screw terminals at the front and via card-edge connector at the rear; terminal cover provided

Connection

Input: M3.5 screw terminals (torque 0.8 N·m)

Output: Card-edge connector and M3.5 screw terminals (torque 0.8 N·m)

Power input: Supplied from card-edge connector

Screw terminal: Nickel-plated steel

Housing material: Flame-resistant resin (black)

Isolation: Voltage input to current input to output to power

Overrange output: Approx. -10 to +120 % at 1 - 5 V

Zero adjustment: -5 to +5 % (front)

Span adjustment: 95 to 105 % (front)

INPUT SPECIFICATIONS

Frequency: 50 or 60 Hz

• Current Input

Operational range: 0 - 120 % of rating

Overload capacity: 1000 % of rating for 3 sec., 200 % for 10 sec., 120% continuous

• Voltage Input

Operational range: 0 - 120 % of rating

Overload capacity: 150 % of rating for 10 sec., 120 % continuous

■ Input Range

How To Determine Var Range:

Calibration Range [var] = Measuring Range ÷ ((VT Ratio) × (CT Ratio))

Check that the required calibration range is within the available range in the table. Specify this range when ordering.

[example]

3-phase / 3-wire, measuring range 75 kvar, VT 220 / 110 V, CT 250 / 5 A

$$75 \times 10^3 \text{ [var]} \div ((220 \div 110) \times (250 \div 5)) = 750 \text{ [var]}$$

•3-phase / 3-wire

INPUT	STD.RANGE	AVAILABLE RANGE	BURDEN (VA)	
			VOLT.	CURR.
110V/1A	200 var	100 - 240 var	0.2 /phase	0.1/phase
110V/5A	1000 var	500 - 1200 var		0.5/phase
220V/1A	400 var	200 - 480 var	0.4 /phase	0.1/phase
220V/5A	2000 var	1000 - 2400 var		0.5/phase

•3-phase / 4-wire

INPUT	STD.RANGE	AVAILABLE RANGE	BURDEN (VA)	
			VOLT.	CURR.
$\frac{110V}{\sqrt{3}}$ /1A	200 var	100 - 240 var	0.1 /phase	0.1/phase
$\frac{110V}{\sqrt{3}}$ /5A	1000 var	500 - 1200 var		0.5/phase
$\frac{190V}{\sqrt{3}}$ /1A	350 var	175 - 420 var	0.2 /phase	0.1/phase
$\frac{190V}{\sqrt{3}}$ /5A	1750 var	875 - 2100 var		0.5/phase
$\frac{220V}{\sqrt{3}}$ /1A	400 var	200 - 480 var	0.3 /phase	0.1/phase
$\frac{220V}{\sqrt{3}}$ /5A	2000 var	1000 - 2400 var		0.5/phase
$\frac{380V}{\sqrt{3}}$ /1A	700 var	350 - 840 var	0.4 /phase	0.1/phase
$\frac{380V}{\sqrt{3}}$ /5A	3500 var	1750 - 4200 var		0.5/phase



OUTPUT SPECIFICATIONS**■ DC Output**

•DC Current: 0 - 20 mA DC and ± 1 mA

Minimum span: 1 mA

Offset: ≤ 1.5 times span

Load resistance: Output drive 12 V max.; 10 V for $[\pm]$ output

■ DC Voltage: -10 - +12 V DC

Minimum span: 5 mV

Offset: Max. 1.5 times span

Load resistance: Output drive 1 mA max. at ≥ 0.5 V

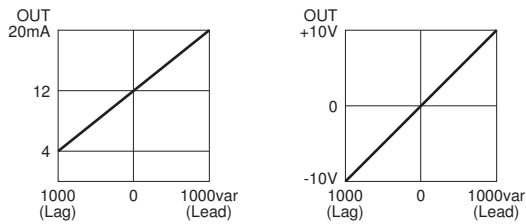
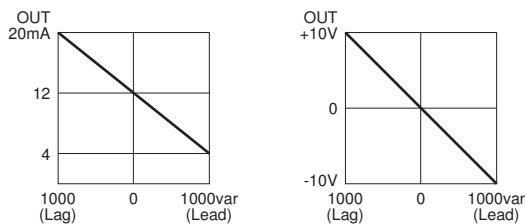
■ OPERATION DIAGRAM (example)**• Negative in lag, positive in lead****• Negative in lead, positive in lag****INSTALLATION**

Current consumption: Approx. 80 mA

Operating temperature: -5 to +55°C (23 to 131°F)

Operating humidity: 30 to 90 %RH (non-condensing)

Mounting: Standard Rack 10BXx

Weight: 450 g (0.99 lb)

PERFORMANCE in percentage of span

Accuracy: ± 0.5 %

Temp. coefficient: ± 0.05 %/°C (± 0.03 %/°F)

Response time: ≤ 1 sec. (0 - 90 %)

Ripple: 0.5 %p-p max. (50/60 Hz)

Line voltage effect: ± 0.1 % over voltage range

Insulation resistance: ≥ 100 M Ω with 500 V DC

Dielectric strength: 2000 V AC @ 1 minute (voltage input to current input to output or power to ground)

500 V AC @ 1 minute (output to power)



CONNECTION DIAGRAM

■ 3-PHASE/3-WIRE

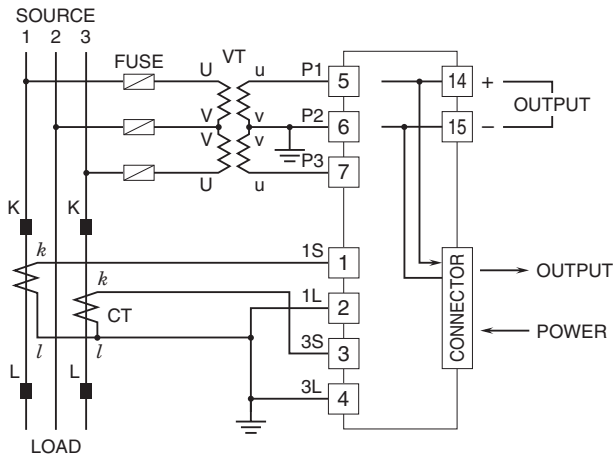

■ 3-PHASE/4-WIRE

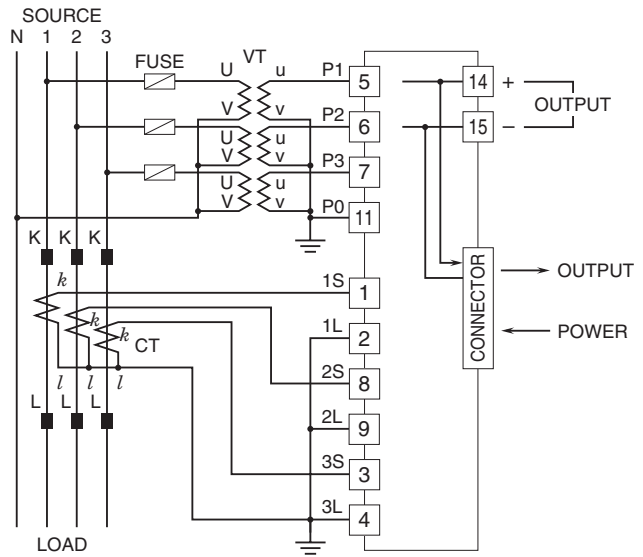

EXTERNAL DIMENSIONS & TERMINAL ASSIGNMENTS unit: mm (inch)

Terminals 8 through 11 are installed only for 3-phase/4-wire model.

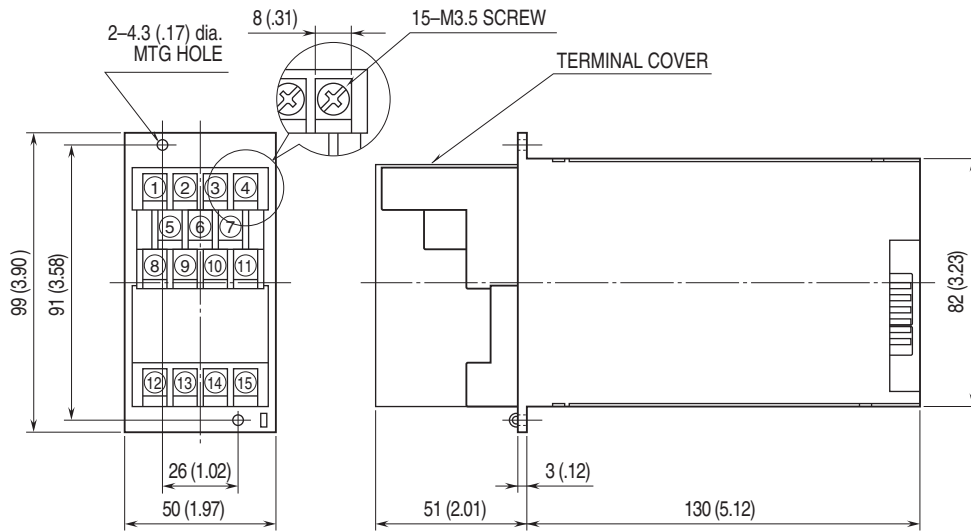

Specifications are subject to change without notice.



幸託有限公司
XIN TOP CORPORATION

TEL : (02)2598-1199
FAX : (02)2596-2331

E-mail : info@xintop.com
Website : www.xintop.com