

High-density Signal Conditioners 10-RACK

PHASE ANGLE TRANSDUCER

Functions & Features

- Providing a DC output signal in proportion to phase angle
- DC output containing little ripple is ideal for computer input
- Isolation up to 2000 V AC (input circuit)

Typical Applications

- Centralized monitoring and control of power management system in a manufacturing facility or building
- Measuring phase angle for a motor

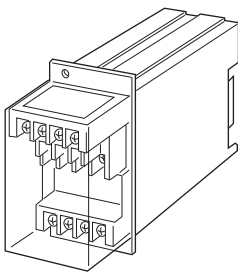

MODEL: 10EPA-[1][2][3][4]-R[5]

ORDERING INFORMATION

- Code number: 10EPA-[1][2][3][4]-R[5]
- Specify a code from below for each [1] through [5].
(e.g. 10EPA-11PA-R/Q)
- Special output range (For codes Z & 0)
 - Specify the specification for option code /Q
(e.g. /C01)

[1] CONFIGURATION

- 1: 3-phase / 3-wire
- 4: 3-phase / 4-wire

[2] INPUT (balanced load)

- 1: 110 V / 5 A AC
 - 2: 110 V / 1 A AC
 - 3: 220 V / 1 A AC
 - 4: 220 V / 5 A AC
 - 5: 220 V / 380 V / 1 A AC (3-phase / 4-wire)
 - 6: 220 V / 380 V / 5 A AC (3-phase / 4-wire)
 - 7: 110 V / 190 V / 1 A AC (3-phase / 4-wire)
 - 8: 110 V / 190 V / 5 A AC (3-phase / 4-wire)
- (220 V in code 5 and 6, and 110 V in code 7 and 8 are phase voltage)

[3] OUTPUT SIGNAL POLARITY

- P: Negative in lag, positive in lead
- M: Negative in lead, positive in lag

[4] OUTPUT

Current

- A: 4 - 20 mA DC (Load resistance 600 Ω max.)
- B: 2 - 10 mA DC (Load resistance 1200 Ω max.)
- C: 1 - 5 mA DC (Load resistance 2400 Ω max.)
- D: 0 - 20 mA DC (Load resistance 600 Ω max.)
- E: 0 - 16 mA DC (Load resistance 750 Ω max.)
- F: 0 - 10 mA DC (Load resistance 1200 Ω max.)
- G: 0 - 1 mA DC (Load resistance 12 kΩ max.)
- GW: -1 - +1 mA DC (Load resistance 10 kΩ max.)
- Z: Specify current (See OUTPUT SPECIFICATIONS)

Voltage

- 1: 0 - 10 mV DC (Load resistance 10 kΩ min.)
- 2: 0 - 100 mV DC (Load resistance 100 kΩ min.)
- 3: 0 - 1 V DC (Load resistance 1000 Ω min.)
- 4: 0 - 10 V DC (Load resistance 10 kΩ min.)
- 5: 0 - 5 V DC (Load resistance 5000 Ω min.)
- 6: 1 - 5 V DC (Load resistance 5000 Ω min.)
- 1W: -10 - +10 mV DC (Load resistance 10 kΩ min.)
- 2W: -100 - +100 mV DC (Load resistance 100 kΩ min.)
- 3W: -1 - +1 V DC (Load resistance 1000 Ω min.)
- 4W: -10 - +10 V DC (Load resistance 10 kΩ min.)
- 5W: -5 - +5 V DC (Load resistance 5000 Ω min.)
- 0: Specify voltage (See OUTPUT SPECIFICATIONS)

POWER INPUT

DC Power

- R: 24 V DC
- (Operational voltage range 24 V ±10 %, ripple 10 %p-p max.)

[5] OPTIONS

- blank: none
- /Q: With options (specify the specification)

SPECIFICATIONS OF OPTION: Q

COATING (For the detail, refer to M-System's web site.)

- /C01: Silicone coating
- /C02: Polyurethane coating
- /C03: Rubber coating

GENERAL SPECIFICATIONS

Construction: Rack-mounted; terminal access via screw terminals at the front and via card-edge connector at the rear; terminal cover provided

Connection

Input: M3.5 screw terminals (torque 0.8 N·m)



Output: Card-edge connector and M3.5 screw terminals (torque 0.8 N·m)

Power input: Supplied from card-edge connector

Screw terminal: Nickel-plated steel

Housing material: Flame-resistant resin (black)

Isolation: Voltage input to current input to output to power

Overrange output: Approx. -10 to +120 % at 1 - 5 V

Zero adjustment: -5 to +5 % (front)

Span adjustment: 95 to 105 % (front)

INPUT SPECIFICATIONS

Frequency: 50 or 60 Hz

• Current Input

Input burden: 0.1 VA (input 1 A)

0.5 VA (input 5 A)

Operational range: 10 - 120 % of rating

Overload capacity: 1000 % of rating for 3 sec., 200 % for 10 sec., 120 % continuous

• Voltage Input

Input burden: Approx. 0.5 VA

Operational range: 85 - 120 % of rating

Overload capacity: 150 % of rating for 10 sec., 120 % continuous

■ Input range:

Lag 60° - 0 - lead 60°

Lead 60° - 0 - lag 60°

OUTPUT SPECIFICATIONS

■ DC Output

• DC Current: 0 - 20 mA DC and ± 1 mA

Minimum span: 1 mA

Offset: ≤ 1.5 times span

Load resistance: Output drive 12 V max.; 10 V for $[\pm]$ output

■ DC Voltage: -10 - +12 V DC

Minimum span: 5 mV

Offset: Max. 1.5 times span

Load resistance: Output drive 1 mA max. at ≥ 0.5 V

■ OPERATION DIAGRAM (example)

• Negative in lag, positive in lead

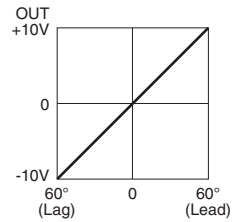
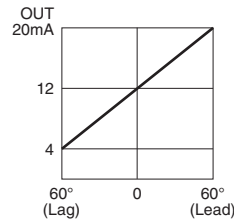

• Negative in lead, positive in lag

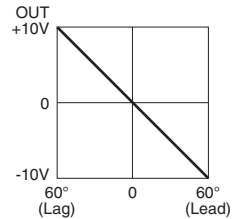
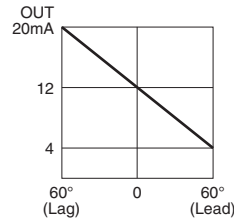

Remark: When there is no input voltage or 5% or less of the rated input current, the output may become unstable (hunting).

INSTALLATION

Current consumption: Approx. 80 mA

Operating temperature: -5 to +55°C (23 to 131°F)

Operating humidity: 30 to 90 %RH (non-condensing)

Mounting: Standard Rack 10BXx

Weight: 400 g (0.88 lb)

PERFORMANCE in percentage of span

Accuracy: ± 2 % with balanced load

Temp. coefficient: ± 0.2 %/°C (± 0.11 %/°F)

Response time: ≤ 1 sec. (0 - 90 %)

Ripple: 0.5 %p-p max. (50/60 Hz)

Line voltage effect: ± 0.1 % over voltage range

Insulation resistance: ≥ 100 M Ω with 500 V DC

Dielectric strength: 2000 V AC @ 1 minute (voltage input to current input to output or power to ground)

500 V AC @ 1 minute (output to power)



CONNECTION DIAGRAM

■ 3-PHASE/3-WIRE

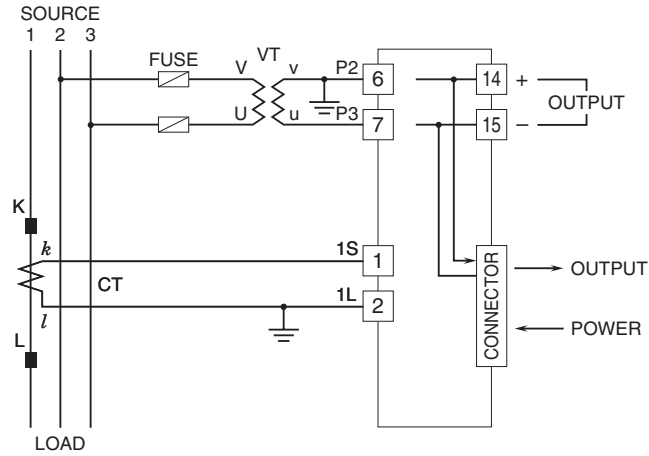

■ 3-PHASE/4-WIRE

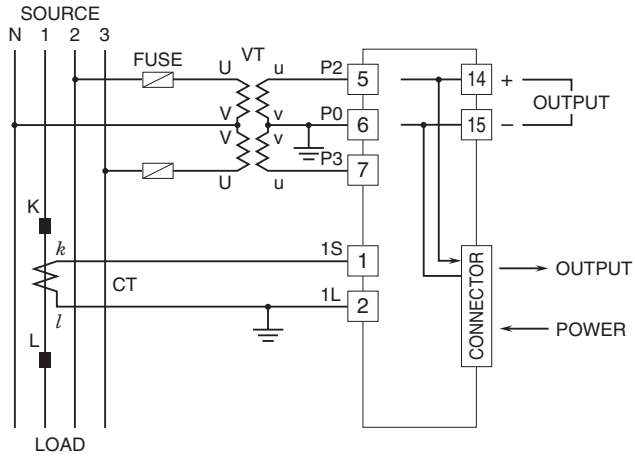

EXTERNAL DIMENSIONS & TERMINAL ASSIGNMENTS unit: mm (inch)

Terminals 8 through 11 are deleted.

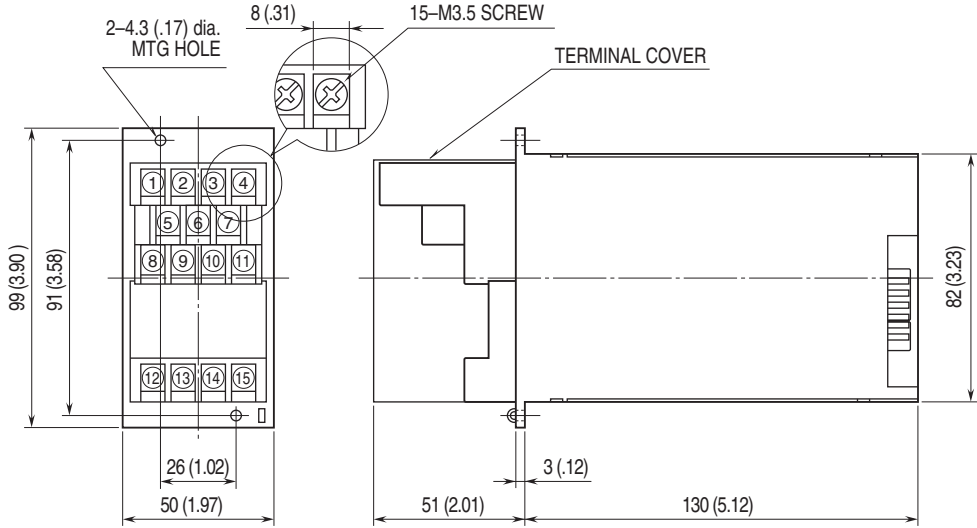

Specifications are subject to change without notice.

