

High-density Signal Conditioners 10-RACK

EXTENDER CARD

Functions & Features

- Enabling the 10-RACK and 15-RACK modules to proceed adjustments at the extracted position without losing electrical connection

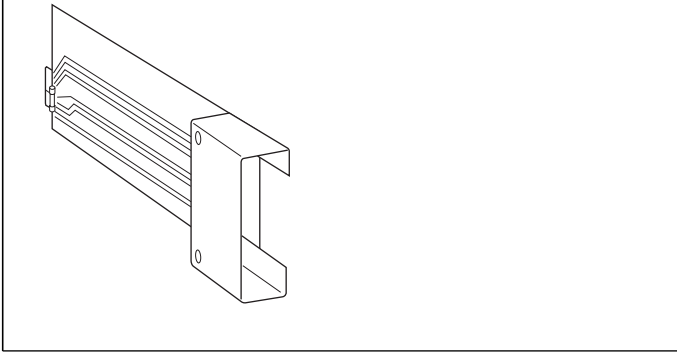

MODEL: 10EC

ORDERING INFORMATION

- Code number: 10EC

SPECIFICATIONS

Power fuse

Model No.: FGMB PBF

Rating: 125 V 0.5 A

INSTALLATION

Weight: 150 g (0.33 lb)

DIMENSIONS unit: mm (inch)

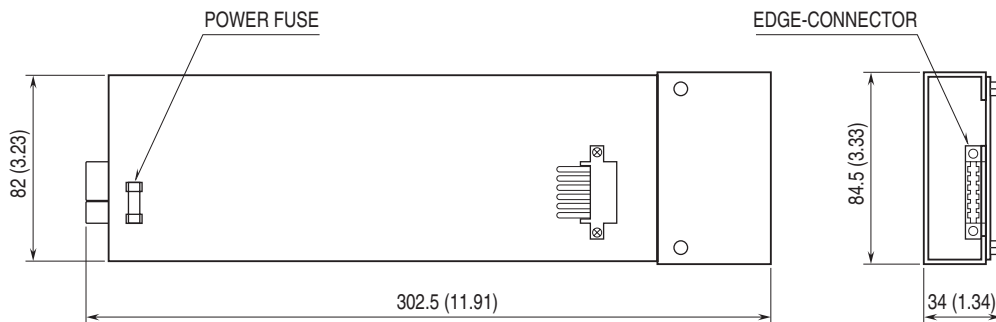

Specifications are subject to change without notice.

