

High-density Signal Conditioners 10-RACK

STANDARD RACK

Functions & Features

- Standard 19" rack for 10-RACK signal conditioners
- Line power supplied via the rear rack bus
- Dual-redundant power supply or two independent power sources selectable with AC power supply
- Supply pressure at manifold plug
- Direct interface to various DCS with the rack connector

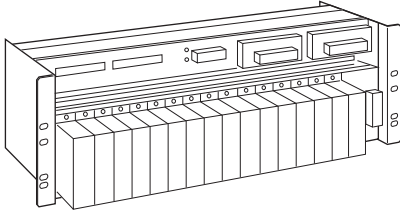

MODEL: 10BXC-[1][2]-[3]

ORDERING INFORMATION

- Code number: 10BXC-[1][2]-[3]
- Specify a code from below for each [1] through [3].
(e.g. 10BXC-12-K2)

[1] FUNCTION

- 1: Power distribution
- 2: Power distribution & pressure supply

[2] CONNECTOR

- 0: None
- 1: Fujitsu FCN type I/O connector
 - 2: Yokogawa DCS connector (MAC2 dual redundant system use)
 - 3: Nippon Shokubai DCS connector
 - 4: Yamatake DCS AI connector
 - 5: Yamatake DCS AO connector
 - 6: Yamatake DCS AI connector (ELCO connector)
 - 7: Yamatake DCS AO connector (ELCO connector)
 - 8: Yokogawa DCS connector (VMx/PM1 dual redundant system use)
- E3: Toshiba DCS SAIN1 card use
H1: Hitachi DCS connector
H2: Hitachi DCS EX-CDL cable connector
- M-System guarantees the connecting section.

[3] POWER SUPPLY UNIT

AC Power

- K: 85 - 132 V AC; single power source
(Operational voltage range 85 - 132 V, 47 - 63 Hz)

K2: 85 - 132 V AC; dual-redundant power supply
(Operational voltage range 85 - 132 V, 47 - 63 Hz)

KK: 85 - 132 V AC; two independent power sources
(Operational voltage range 85 - 132 V, 47 - 63 Hz)

L: 170 - 264 V AC; single power source
(Operational voltage range 170 - 264 V, 47 - 63 Hz)

L2: 170 - 264 V AC; dual-redundant power supply
(Operational voltage range 170 - 264 V, 47 - 63 Hz)

DC Power

R: 24 V DC; no power supply unit
(Operational voltage range 24 V \pm 10 %, ripple 10 %p-p max.)

AC/DC Power

KR: 85 - 132 V AC / 24 V DC; two independent power sources
(85 - 132 V, 47 - 63 Hz or 24V \pm 10 %, ripple 10 %p-p max.)
(Redundant or independent power sources are recommended for long time use without interruption.)

RELATED PRODUCTS

- Blank filler plate (model: P-101)
- Connector terminal block (model: CNT)
- Special cable with 40-pin connector (model: FCN)

GENERAL SPECIFICATIONS

Construction: Metal plates assembly

Capacity: 16 positions

Connection

Power input: M4 screw terminals (torque 0.8 N·m)

Power alarm: M4 screw terminals (torque 0.8 N·m)

Pneumatic: Rc 3/8" female (torque \leq 12 N·m)

Screw terminal: Nickel-plated brass

Manifold: Aluminium alloy

Isolation: I/O connector to alarm output to power to FG

Power alarm output: N.C. contact turns off at power failure or failure of power units. Supplied only with dual-redundant power supply or two independent power sources

Power RUN LED: Light turns on in normal conditions
(supplied only with dual-redundant power supply or two independent power sources)

OUTPUT SPECIFICATIONS

■ Alarm Output

(Supplied only with dual-redundant power supply or two independent power sources)

Rated load: 250 V AC @ 3 A ($\cos \theta = 1$)

30 V DC @ 3 A (resistive load)

Maximum switching voltage: 250 V AC or 125 V DC

Maximum switching power: 750 VA or 60 W

Minimum load: 5 V DC @ 100 mA

Mechanical life: 5×10^6 cycles (rate 180 cycles/min.)



INSTALLATION

Supply pressure: Refer to the data sheet for I/P transducers (10BXC-2 only)

Power consumption

- AC: 130 VA min.
- DC: 2.5 A min.

Operating temperature: -5 to +55°C (23 to 131°F) 0 to 50°C (32 to 122°F) for AC power

Operating humidity: 30 to 90 %RH (non-condensing)

Mounting: JIS or EIA standard rack

Weight

Single power supply w/o power units:

- 3.0 kg (6.6 lbs) with DC power type
- 3.5 kg (7.7 lbs) with AC power type

Dual-redundant or two independent power sources:

- 3.5 kg (7.7 lbs) with AC/DC power type
- 4.0 kg (8.8 lbs) with AC/AC power type
- Add 2 kg (4.4 lbs) for air manifold type.

PERFORMANCE

Insulation resistance: $\geq 100 \text{ M}\Omega$ with 500 V DC

Dielectric strength: 500 V AC @ 1 minute (I/O connector to alarm output to power)

1500 V AC @ 1 minute (power to FG)

500 V AC @ 1 minute (I/O connector or alarm output to FG,

1000 AC with power input code R)

Maximum supply pressure: 196 kPa

(2 kgf/cm², 1.96 bar, 28 psig)

MOUNTING REQUIREMENTS

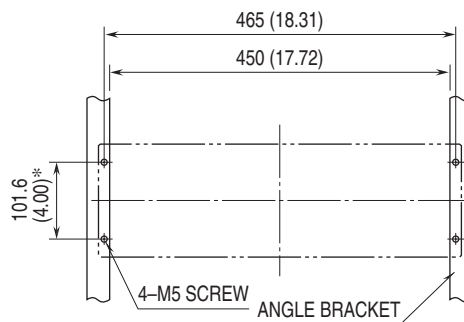

Observe an appropriate wiring space below.
*100 (3.94) for JIS standard



CONNECTION DIAGRAM

Remark 1: No.s of connectors may change with model suffix code.

Remark 2: Supply pressure connection provided only for 10BXC-2.

■ Single Power Source, Dual-redundant Power Supply

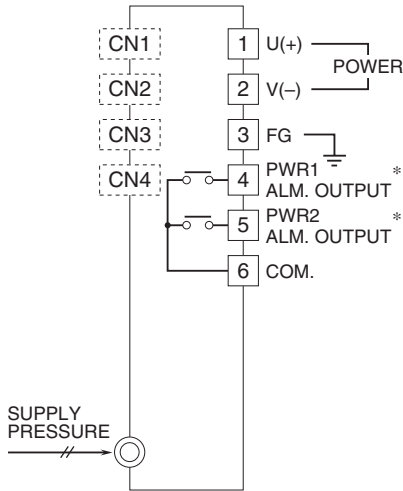

■ Two Independent Power Sources, DC/AC Power Supply

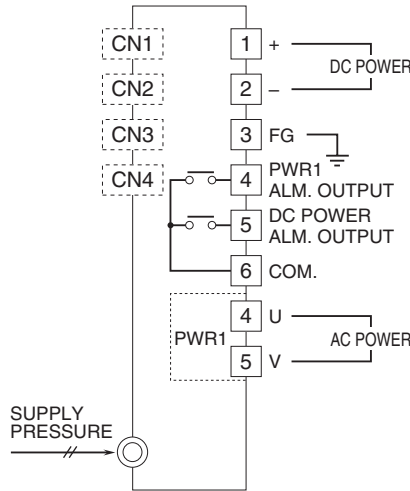

■ Two Independent Power Sources, AC/AC Power Supply

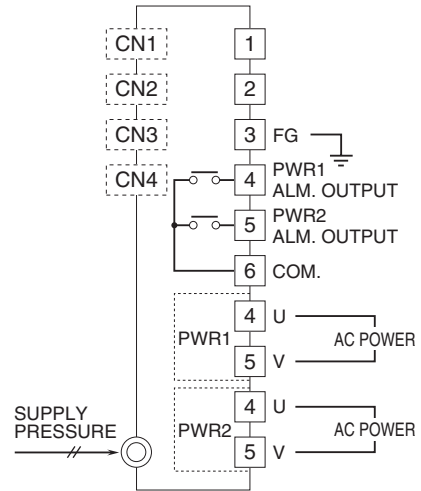

*Alarm output not provided for single power supply.

DIMENSIONS unit: mm (inch)

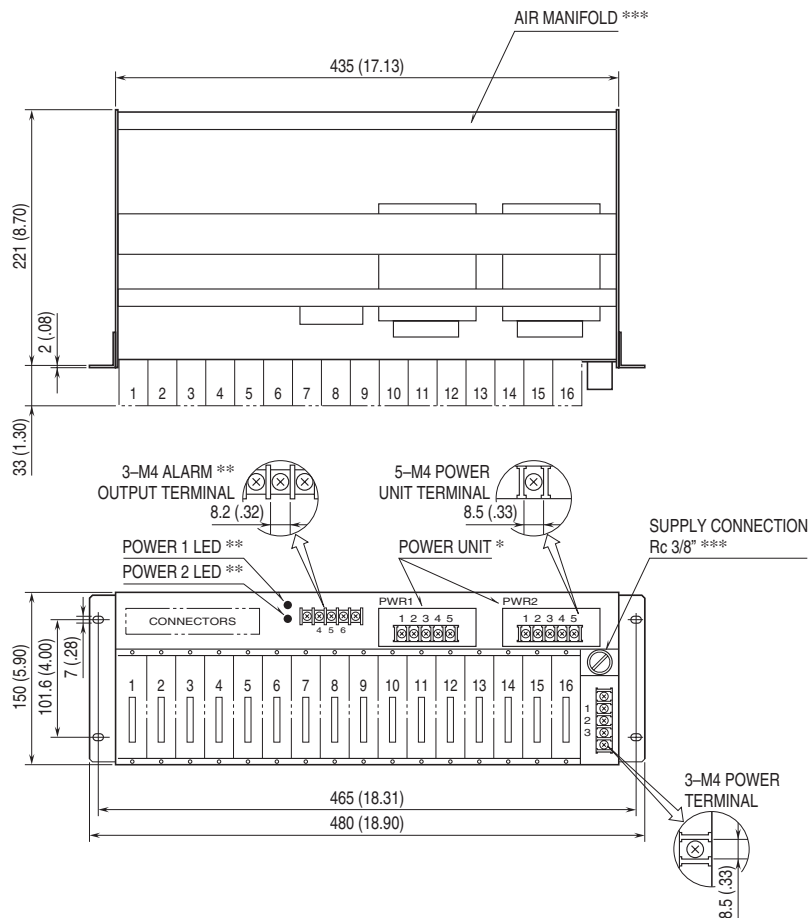

* PWR1 only for AC single power supply.

** Alarm output provided only for dual-redundant power supply or two independent power sources.

***Pneumatic connection provided only for model 10BXC-2.



I/O CONNECTOR PIN ASSIGNMENT

Fujitsu FCN type I/O connector

•Connector Pin Assignment

CN1: Fujitsu FCN-364P040-AU

The input or output 2 (output 1 with single output type) is connected to the connector.

PIN NO.	ASSIGNMENT	PIN NO.	ASSIGNMENT
A 1	ch. 1 +	B 1	ch. 1 -
A 2	ch. 2 +	B 2	ch. 2 -
A 3	ch. 3 +	B 3	ch. 3 -
A 4	ch. 4 +	B 4	ch. 4 -
A 5	ch. 5 +	B 5	ch. 5 -
A 6	ch. 6 +	B 6	ch. 6 -
A 7	ch. 7 +	B 7	ch. 7 -
A 8	ch. 8 +	B 8	ch. 8 -
A 9	ch. 9 +	B 9	ch. 9 -
A10	ch.10 +	B10	ch.10 -
A11	ch.11 +	B11	ch.11 -
A12	ch.12 +	B12	ch.12 -
A13	ch.13 +	B13	ch.13 -
A14	ch.14 +	B14	ch.14 -
A15	ch.15 +	B15	ch.15 -
A16	ch.16 +	B16	ch.16 -

A17 - A20, B17 - B20: Unused

Yokogawa DCS connector

•Location

I/O connector: PS-40PE-D4T1-PN1

CN1: MAC2 / PAC card use*

CN2: MAC2 / PAC card use* for redundancy

CN3: VMx / PM1 card use**

The input or output 2 (output 1 with single output type) is connected to the connector.

RACK LOCATION NO.															
1	2	3	4	5	6	7	8	9	10	11	12	13	14	15	16
1	2	3	4	5	6	7	8	9	10	11	12	13	14	15	16
VM1/PM1/VM4 CARD INPUT or OUTPUT CN3															
VM2 CARD INPUT NO. CN3								VM2 CARD OUTPUT NO. CN3							
1	1	2	2	3	3	4	4	5	5	6	6	7	7	8	8
i	o	i	o	i	o	i	o	i	o	i	o	i	o	i	o
MAC2/PAC CARD I/O (i = input, o = output) CN1, CN2															

*MAC2 card (uses KS1 cable)

I/O card used for control I/O. Composed of 8 inputs and 8 outputs. Input and output are paired. (Replace with pulse inputs for PAC card.)

**VMx / PM1 card (uses KS2 cable)

VM1: analog input 16 points

VM2: analog input 8 points / analog output 8 points

VM4: analog output 16 points

PM1: pulse input 16 points

Nippon Shokubai DCS connector

•Location

CN1: HIF3F-34PA-2.54DSA

The input or output 2 (output 1 with single output type) is connected to the connector.

RACK LOCATION NO.															
1	2	3	4	5	6	7	8	9	10	11	12	13	14	15	16
1	2	3	4	5	6	7	8	9	10	11	12	13	14	15	16
NIPPON SHOKUBAI DCS LOCATION NO.															

•Connector Pin Assignment

PIN NO.	ASSIGNMENT	PIN NO.	ASSIGNMENT
1	No Connection	19	ch. 8 -
2	No Connection	20	ch. 8 +
3	ch.16 -	21	ch. 7 -
4	ch.16 +	22	ch. 7 +
5	ch.15 -	23	ch. 6 -
6	ch.15 +	24	ch. 6 +
7	ch.14 -	25	ch. 5 -
8	ch.14 +	26	ch. 5 +
9	ch.13 -	27	ch. 4 -
10	ch.13 +	28	ch. 4 +
11	ch.12 -	29	ch. 3 -
12	ch.12 +	30	ch. 3 +
13	ch.11 -	31	ch. 2 -
14	ch.11 +	32	ch. 2 +
15	ch.10 -	33	ch. 1 -
16	ch.10 +	34	ch. 1 +
17	ch. 9 -		
18	ch. 9 +		

Yamatake DCS AI connector

I/O cable: J-RSL / J-RSK

J-RRL / J-RRK

•Location

Input connector: 57GE-40500-751

CN1, CN2: J-HAM50 / J-HMM00 module use

The output 2 (output 1 with single output type) is connected to the connector. The CN1 and CN2 are connected in parallel.

RACK LOCATION NO.															
1	2	3	4	5	6	7	8	9	10	11	12	13	14	15	16
1	2	3	4	5	6	7	8	9	10	11	12	13	14	15	16
YAMATAKE DCS AI CONNECTOR															

Yamatake DCS AO connector

I/O cable: J-RSL / J-RSK

J-RRL / J-RRK

•Location

Output connector: 57GE-40500-751

CN1, CN2: J-AOM10 module use

The input is connected to the connector. The CN1 and CN2 are connected in parallel.

Install the Extender Module (model: 10BW) to unused channels in order to close the circuit.

RACK LOCATION NO.															
1	2	3	4	5	6	7	8	9	10	11	12	13	14	15	16
1	2	3	4	5	6	7	8	9	10	11	12	13	14	15	16
YAMATAKE DCS AO CONNECTOR															



Yamatake DCS AI connector

I/O cable: J-SSL / J-SSK
J-SRL / J-SRK

•Location

Input connector: 00-8016-056-296-707V

CN1, CN2: J-HAM50 / J-HMM00 module use
The output 2 (output 1 with single output type) is connected to the connector. The CN1 and CN2 are connected in parallel.

RACK LOCATION NO.															
1	2	3	4	5	6	7	8	9	10	11	12	13	14	15	16
1	2	3	4	5	6	7	8	9	10	11	12	13	14	15	16

YAMATAKE DCS AI CONNECTOR

Yamatake DCS AO connector

I/O cable: J-SSL / J-SSK
J-SRL / J-SRK

•Location

Output connector: 00-8016-056-296-707V

CN1, CN2: J-AOM10 module use
The input is connected to the connector. The CN1 and CN2 are connected in parallel.
Install the Extender Module (model: 10BW) to unused channels in order to close the circuit.

RACK LOCATION NO.															
1	2	3	4	5	6	7	8	9	10	11	12	13	14	15	16
1	2	3	4	5	6	7	8	9	10	11	12	13	14	15	16

YAMATAKE DCS AO CONNECTOR

Yokogawa DCS connector

•Location

I/O connector: PS-40PE-D4T1-PN1

CN1: VMx / PM1 card use (uses KS2 cable)

CN2: VMx / PM1 card use for redundancy

The input or output 2 (output 1 with single output type) is connected to the connector.

RACK LOCATION NO.															
1	2	3	4	5	6	7	8	9	10	11	12	13	14	15	16
1	2	3	4	5	6	7	8	9	10	11	12	13	14	15	16
VM1/PM1/VM4 CARD INPUT or OUTPUT CN1, CN2															
1	2	3	4	5	6	7	8	1	2	3	4	5	6	7	8
VM2 CARD INPUT NO. CN1, CN2								VM2 CARD OUTPUT NO. CN1, CN2							

•Connector Pin Assignment

PIN NO.	ASSIGNMENT	PIN NO.	ASSIGNMENT
40	ch. 1 +	24	ch. 9 +
39	ch. 1 -	23	ch. 9 -
38	ch. 2 +	22	ch.10 +
37	ch. 2 -	21	ch.10 -
36	ch. 3 +	20	ch.11 +
35	ch. 3 -	19	ch.11 -
34	ch. 4 +	18	ch.12 +
33	ch. 4 -	17	ch.12 -
32	ch. 5 +	16	ch.13 +
31	ch. 5 -	15	ch.13 -
30	ch. 6 +	14	ch.14 +
29	ch. 6 -	13	ch.14 -
28	ch. 7 +	12	ch.15 +
27	ch. 7 -	11	ch.15 -
26	ch. 8 +	10	ch.16 +
25	ch. 8 -	9	ch.16 -

1 - 8: Unused

VM1: analog input 16 points

VM2: analog input 8 points / analog output 8 points

VM4: analog output 16 points

PM1: pulse input 16 points

Toshiba DCS SAIN1 card use

•Location

Input connector: AXM220001

CN1: SAIN1 (ch.1 - ch.8)

CN2: SAIN1 (ch.1 - ch.8) for redundancy

CN3: SAIN1 (ch.9 - ch.16)

CN4: SAIN1 (ch.9 - ch.16) for redundancy

The output 2 (output 1 with single output type) is connected to the connector.

RACK LOCATION NO.															
1	2	3	4	5	6	7	8	9	10	11	12	13	14	15	16
1	2	3	4	5	6	7	8	1	2	3	4	5	6	7	8
CN1, CN2								CN3, CN4							
SAIN1 INPUT POINT NO.															



Hitachi DCS connector

•Location

CN1, CN2: DN20B-36S

The input or output 2 (Output 1 with single output type) is connected to the connector.

RACK LOCATION NO.															
1	2	3	4	5	6	7	8	9	10	11	12	13	14	15	16
1	2	3	4	5	6	7	8	9	10	11	12	13	14	15	16
HITACHI DCS CONNECTOR															

•Connector Pin Assignment

PIN NO.	ASSIGNMENT	PIN NO.	ASSIGNMENT
1	ch. 1 +	9	ch. 9 +
19	ch. 1 -	27	ch. 9 -
2	ch. 2 +	10	ch.10 +
20	ch. 2 -	28	ch.10 -
3	ch. 3 +	11	ch.11 +
21	ch. 3 -	29	ch.11 -
4	ch. 4 +	12	ch.12 +
22	ch. 4 -	30	ch.12 -
5	ch. 5 +	13	ch.13 +
23	ch. 5 -	31	ch.13 -
6	ch. 6 +	14	ch.14 +
24	ch. 6 -	32	ch.14 -
7	ch. 7 +	15	ch.15 +
25	ch. 7 -	33	ch.15 -
8	ch. 8 +	16	ch.16 +
26	ch. 8 -	34	ch.16 -

Hitachi DCS EX-CDL cable connector

•Location

CN1: 57GE-40360-751 (D7A)

The input or output 2 (output 1 with single output type) is connected to the connector.

PIN NO.	ASSIGNMENT	PIN NO.	ASSIGNMENT
1	ch. 1 +	9	ch. 9 +
19	ch. 1 -	27	ch. 9 -
2	ch. 2 +	10	ch.10 +
20	ch. 2 -	28	ch.10 -
3	ch. 3 +	11	ch.11 +
21	ch. 3 -	29	ch.11 -
4	ch. 4 +	12	ch.12 +
22	ch. 4 -	30	ch.12 -
5	ch. 5 +	13	ch.13 +
23	ch. 5 -	31	ch.13 -
6	ch. 6 +	14	ch.14 +
24	ch. 6 -	32	ch.14 -
7	ch. 7 +	15	ch.15 +
25	ch. 7 -	33	ch.15 -
8	ch. 8 +	16	ch.16 +
26	ch. 8 -	34	ch.16 -



Specifications are subject to change without notice.

