

## Space-saving Signal Conditioners M3-UNIT Series

### RTD TRANSMITTER

(field- and PC-configurable)

#### Functions & Features

- Accepts an RTD input and provides an isolated, linearized DC signal
- Easy 'One-Step Cal' calibration using the front three control buttons without needing a PC; PC software is also usable.
- Both input and output type and range are configurable
- Front control button function can be locked
- Linearization and burnout

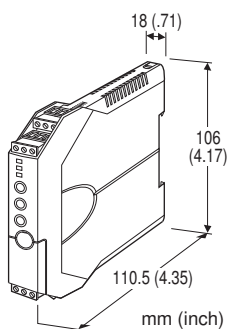

## MODEL: M3LR-R4/[1][2]

### ORDERING INFORMATION

- Code number: M3LR-R4/[1][2]
- Specify a code from below for each [1] and [2]. (e.g. M3LR-R4/A/Q)
- Specify the specification for option code /Q (e.g. /C01)
- Orders will be shipped with default factory settings (3-wire Pt 100, 0 - 100°C input/4 - 20 mA output).

### INPUT - Field-selectable

#### RTD

Pt 100, Pt 200, Pt 300, Pt 400, Pt 500, Pt 1000,  
Ni 100, Ni 120, Ni 508.4Ω, Ni-Fe 604,  
Cu 10 @25°C, Pt 50Ω, JPt 100

### OUTPUT - Field-selectable

#### Current

0 - 20 mA DC

#### Voltage

-2.5 - +2.5 V DC

-10 - +10 V DC

### POWER INPUT

#### DC Power

R4: 10 - 32 V DC

(Operational voltage range 9 - 36 V, ripple 10 %p-p max.)

### [1] CONFIGURATION OPTIONS

A: PC and field configurable

B: Field configurable

### [2] OPTIONS

#### Standards & Approvals

blank: CE marking

/UL: UL approval, CE marking

#### Other Options

blank: none

/Q: Option other than the above (specify the specification)

(UL not available)

### SPECIFICATIONS OF OPTION: Q

#### COATING (For the detail, refer to M-System's web site.)

/C01: Silicone coating

/C02: Polyurethane coating

/C03: Rubber coating

### RELATED PRODUCTS

- PC configurator software (model: M3CFG)

Downloadable at M-System's web site.

A dedicated cable is required to connect the module to the PC. Please refer to the internet software download site or the users manual for the PC configurator for applicable cable types.

### GENERAL SPECIFICATIONS

**Construction:** Small-sized front terminal structure

**Connection:** Euro type connector terminal

**Housing material:** Flame-resistant resin (gray)

**Isolation:** Input to output to power

**Overrange output:** -15 to +115 %

**Zero adjustment:** -15 to +15 % (front)

**Span adjustment:** 85 to 115 % (front)

**Burnout:** Upscale (default), downscale or no burnout selectable

**Linearization:** Standard

**Status indicator LED:** Tri-color (green/amber/red) LED;

Blinking patterns indicate operation status of the transmitter.

**Configuration:**

**PC Configurator:** (Model: M3LVCFG) via Windows PC connected to the front jack.

**Programmable features include:**



幸託有限公司

XIN TOP CORPORATION

TEL : (02)2598-1199

FAX : (02)2596-2331

E-mail : info@xintop.com

Website : www.xintop.com

- I/O type, number of wires and range
  - Zero and span adjustments
  - Burnout action
  - User's RTD table setting
- (max. 300 points, input resistance specified within 0 – 30 kΩ)  
(Refer to the instruction manual)

**'One-Step Cal' calibration:** With I/O type and the full-scale range configured via the internal DIP switches, precise 0 % and 100 % ranges are calibrated via the front control buttons with a help of LED. Also I/O calibration and fine adjustment are available with a PC.

**Configurator connection:** 2.5 dia. miniature jack;  
RS-232-C level

## INPUT SPECIFICATIONS

■ RTD: See Table 1.

**Number of wires:** 2, 3 or 4 wires

**Excitation:** ≤ 1.0 mA

**Allowable leadwire resistance:** 20 Ω per wire

**Temperature range:** See Table 1.

## OUTPUT SPECIFICATIONS

■ DC Current

**Maximum range:** 0 – 20 mA DC

**Minimum span:** 1 mA

**Conformance range:** 0 – 24 mA DC

(Negative overrange current below 0 mA is not available.)

**Offset:** Lower range can be any specific value within the output range provided that the minimum span is maintained.

**Load resistance:** Output drive 12 V maximum

■ DC Voltage

**Narrow Spans**

**Maximum range:** -2.5 – +2.5 V DC

**Minimum span:** 250 mV

**Conformance range:** -3 – +3 V DC

**Wide Spans**

**Maximum range:** -10 – +10 V DC

**Minimum span:** 1 V

**Conformance range:** -11.5 – +11.5 V DC

**Offset:** Lower range can be any specific value within the output range provided that the minimum span is maintained.

**Load resistance:** Output drive 1 mA maximum

## INSTALLATION

**Power consumption**

•DC: Approx. 3 W

**Operating temperature:** -25 to +65°C (-13 to +149°F)

Max. 55°C (131°F) for UL approval

**Operating humidity:** 0 to 95 %RH (non-condensing)

**Mounting:** DIN rail

**Weight:** 100 g (3.53 oz)

## PERFORMANCE

**Accuracy:** See Table 1 and refer to calculation examples of overall accuracy.

**Temp. coefficient:** ±0.015 %/°C (±0.008 %/°F) of max. range at -5 to +55°C (23 to 131°F)

**Response time:** ≤ 0.9 sec. (0 – 90 %)

**Burnout response:** ≤ 10 sec.

**Line voltage effect:** ±0.1 % over voltage range

**Insulation resistance:** ≥ 100 MΩ with 500 V DC

**Dielectric strength:** 1500 V AC @ 1 minute

(input to output or power to ground)

500 V AC @ 1 minute (output to power)

## CALCULATION EXAMPLES OF OVERALL ACCURACY

■ CALCULATION EXAMPLES OF OVERALL ACCURACY IN %

1) Pt 100, 0 – 500°C, 4 – 20 mA DC output

**Absolute value accuracy (Table 1):** 0.15°C

$0.15^{\circ}\text{C} \div 500^{\circ}\text{C} \times 100 = 0.03\% < 0.1\%$

Output span 16 mA (20 – 4) ≥ 2 mA (max. span 20 mA × 0.1) ⇒ No adding 0.2 %

⇒ Overall accuracy = ±0.1 % of span

2) Pt 100, 0 – 100°C, 2.0 – 2.5 V DC output

**Absolute value accuracy (Table 1):** 0.15°C

$0.15^{\circ}\text{C} \div 100^{\circ}\text{C} \times 100 = 0.15\% > 0.1\%$

Output span 0.5 V (2.5 – 2.0) ≤ 0.5 (max. span 5 V × 0.1) ⇒ Add 0.2 %

⇒ Overall accuracy = 0.15 + 0.2 = ±0.35 % of span

## STANDARDS & APPROVALS

**EU conformity:**

EMC Directive

EMI EN 61000-6-4

EMS EN 61000-6-2

RoHS Directive

EN 50581

**Approval:**

UL/C-UL general safety requirements

(UL 61010-1, CAN/CSA-C22.2 No.1010-1)



## EXTERNAL VIEW

### FRONT VIEW

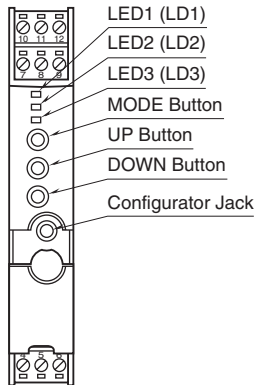

### SIDE VIEW

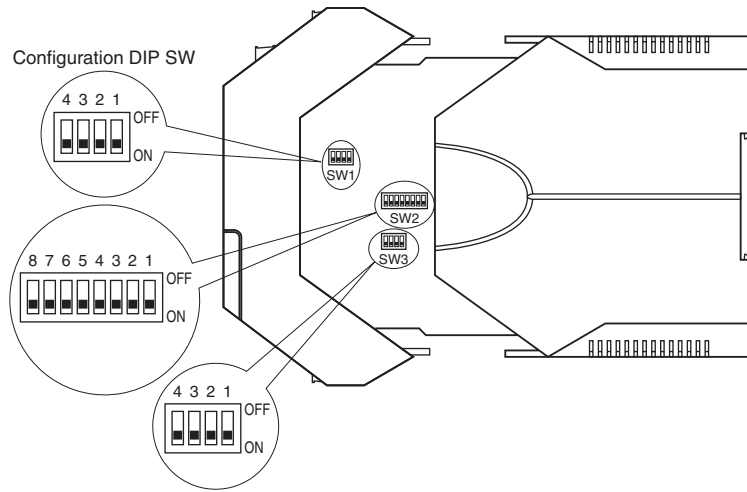

The DIP switch setting is required to select output types before setting a precise output range using the PC configurator software.

For detailed information on the configuration and calibration, refer to the instruction manual.

## INPUT TYPE, RANGE & ACCURACY

### INPUT TYPE, RANGE & ACCURACY

TABLE 8

RTD	°C			°F		
	MIN.SPAN	MAXIMUM RANGE	ACCURACY*1	MIN.SPAN	MAXIMUM RANGE	ACCURACY*1
Pt 100 (JIS '97, IEC)	20	-200 to +850	±0.15	36	-328 to +1562	±0.27
Pt 200	20	-200 to +850	±0.15	36	-328 to +1562	±0.27
Pt 300	20	-200 to +850	±0.15	36	-328 to +1562	±0.27
Pt 400	20	-200 to +850	±0.15	36	-328 to +1562	±0.27
Pt 500	20	-200 to +850	±0.15	36	-328 to +1562	±0.27
Pt 1000	20	-200 to +850	±0.15	36	-328 to +1562	±0.27
Pt 50Ω (JIS '81)	20	-200 to +649	±0.15	36	-328 to +1200	±0.27
JPt 100 (JIS '89)	20	-200 to +510	±0.15	36	-328 to +950	±0.27
Ni 100	20	-80 to +260	±0.15	36	-112 to +500	±0.27
Ni 120	20	-80 to +260	±0.15	36	-112 to +500	±0.27
Ni 508.4Ω	20	-50 to +200	±0.15	36	-58 to +392	±0.27
Ni-Fe 604	20	-200 to +200	±0.15	36	-328 to +392	±0.27
Cu 10 @25°C	20	-50 to +250	±0.50	36	-58 to +482	±0.90

\*1. Or ±0.1% of span, whichever is greater.

If the selected output span equals to or narrower than the one-tenth of the maximum span, add 0.2%.



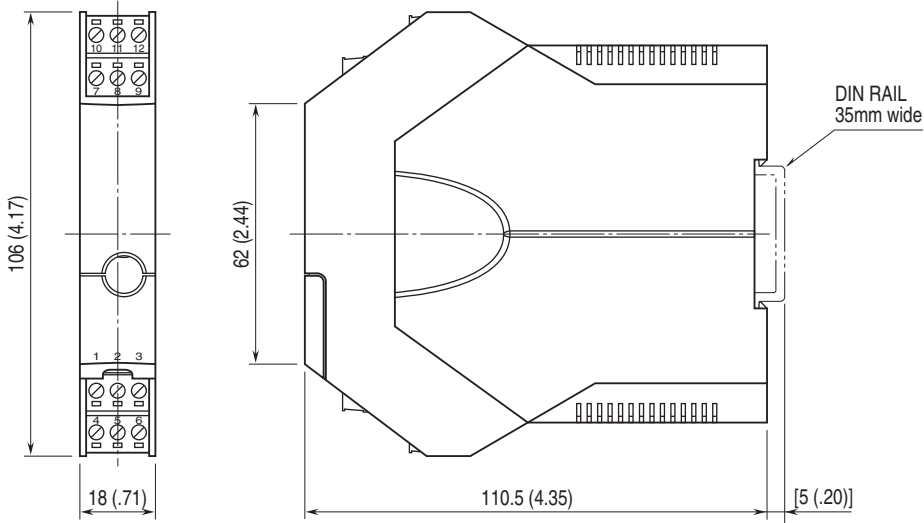

**EXTERNAL DIMENSIONS & TERMINAL ASSIGNMENTS unit: mm (inch)**

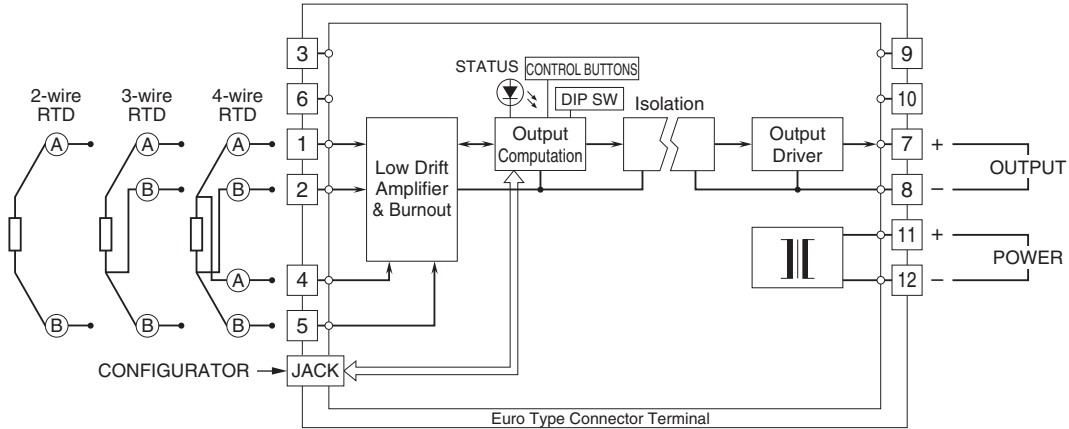

• When mounting, no extra space is needed between units.

**SCHEMATIC CIRCUITRY & CONNECTION DIAGRAM**



 Specifications are subject to change without notice.

