

Space-saving Signal Conditioners M3-UNIT Series

CURRENT LOOP SUPPLY

(linearizing; field- and PC-configurable)

Functions & Features

- Powers a 4 - 20 mA DC current loop
- Shortcircuit protection
- Applicable to smart transmitters
- PC-programmable linearization data (100 points and square root extraction)
- Easy 'One-Step Cal' calibration using the front three control buttons without needing a PC
- Front control button function can be locked
- Loop testing via the PC configuration software

Typical Applications

- Various 2-wire transmitters
- Linearizing weir flowmeter output to provide a linear-to-volume signal
- Isolator application (0 - 20 mA input)
- Square root extraction for differential pressure transmitter
- Ideal for use as a fast solution, multifunctional spare part

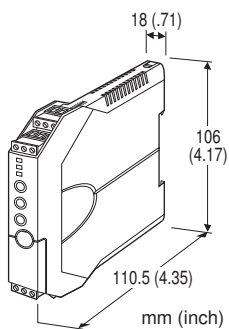

MODEL: M3LDY-R/[1][2]

ORDERING INFORMATION

- Code number: M3LDY-R/[1][2]

Specify a code from below for each [1] and [2].

(e.g. M3LDY-R/A/Q)

- Specify the specification for option code /Q

(e.g. /C01)

Orders will be shipped with default factory settings (4 - 20 mA input / 4 - 20 mA output).

INPUT

Current

0 - 20mA DC (Input resistance 274.9 Ω)

OUTPUT - Field-selectable

Current

0 - 20 mA DC

Voltage

-2.5 - +2.5 V DC

-10 - +10 V DC

POWER INPUT

DC Power

R: 24 V DC

(Operational voltage range 24 V ±10 %, ripple 10 %p-p max.)

[1] CONFIGURATION OPTIONS

A: PC and field configurable

B: Field configurable

[2] OPTIONS

Standards & Approvals

blank: CE marking

/UL: UL approval, CE marking

Other Options

blank: none

/Q: Option other than the above (specify the specification)

(UL not available)

SPECIFICATIONS OF OPTION: Q

COATING (For the detail, refer to M-System's web site.)

/C01: Silicone coating

/C02: Polyurethane coating

/C03: Rubber coating

RELATED PRODUCTS

- PC configurator software (model: M3CON)

Downloadable at M-System's web site.

A dedicated cable is required to connect the module to the PC. Please refer to the internet software download site or the users manual for the PC configurator for applicable cable types.

GENERAL SPECIFICATIONS

Construction: Small-sized front terminal structure

Connection: Euro type connector terminal

Housing material: Flame-resistant resin (gray)

Isolation: Input to output to power

Overrange output: -15 to +115 %

Zero adjustment: -15 to +15 % (front)

Span adjustment: 85 to 115 % (front)

Status indicator LED: Tri-color (green/amber/red) LED;

Blinking patterns indicate operation status of the



幸託有限公司

XIN TOP CORPORATION

TEL : (02)2598-1199

FAX : (02)2596-2331

E-mail : info@xintop.com

Website : www.xintop.com

transmitter.

Configuration

PC configurator: (Model: M3LDYCON) via Windows PC connected to the front jack.

Programmable features include:

- Input range
- Output type and range
- Zero and span adjustments
- Linearization
- Loop test output

(Refer to the instruction manual)

'One-Step Cal' calibration: With I/O type and the full-scale range configured via the internal DIP switches, precise 0 % and 100 % ranges are calibrated via the front control buttons with a help of LED. Also I/O calibration and fine adjustment are available with a PC.

Configurator connection: 2.5 dia. miniature jack; RS-232-C level

SUPPLY OUTPUT

■ SUPPLY OUTPUT (across the terminals 1 - 2)

Output voltage: 24 - 28 V DC with no load

19 V DC minimum at 20 mA

Current rating: ≤ 22 mA DC

Permissible load resistance:

$LR (\Omega) \leq (19 - \text{Min. Operational Voltage})V \div 0.02 A$

- Shortcircuit Protection

Current limited: 35 mA max.

Protected time duration: No limit

INPUT SPECIFICATIONS

■ DC Current:

Input resistor: Resistor incorporated
(24.9Ω for isolator use)

Maximum range: 0 - 20 mA DC

Minimum span: 2 mA

Offset: Lower range can be any specific value within the input range provided that the minimum span is maintained.

OUTPUT SPECIFICATIONS

■ DC Current

Maximum range: 0 - 20 mA DC

Minimum span: 1 mA

Conformance range: 0 - 24 mA DC

(Negative overrange current below 0 mA is not available.)

Offset: Lower range can be any specific value within the output range provided that the minimum span is maintained.

Load resistance: Output drive 12 V maximum

■ DC Voltage

Narrow Spans

Maximum range: -2.5 - +2.5 V DC

Minimum span: 250 mV

Conformance range: -3 - +3 V DC

Wide Spans

Maximum range: -10 - +10 V DC

Minimum span: 1 V

Conformance range: -11.5 - +11.5 V DC

Offset: Lower range can be any specific value within the output range provided that the minimum span is maintained.

Load resistance: Output drive 1 mA maximum

LINEARIZATION (/A only)

Type selection and data programming: PC Configurator Software

- **No Linearization:** The output is proportional to the input.
- **Segment Data:** 100 points max. within the range of -15.00 to +115.00 % input or output represented as percentage of full-scale

Low-end cutout: Low-end cutout point selectable within the range of 0 to 100 %. For the input lower than the low-end cutout point, the output signal equals 0 %.

• Square Root Extraction

Low-end cutout: Low-end cutout point selectable within the range of 0 to 100 %. For the input lower than the low-end cutout point, the output signal is linear to the input.

• Segment Data :

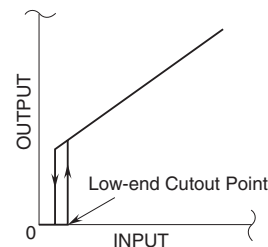

• Square Root Extraction

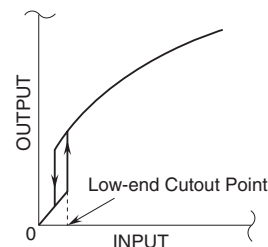

INSTALLATION

Power consumption

•DC: Approx. 3 W

Operating temperature: -25 to +65°C (-13 to +149°F)

Max. 55°C (131°F) for UL approval

Operating humidity: 0 to 95 %RH (non-condensing)

Mounting: DIN rail

Weight: 100 g (3.53 oz)

PERFORMANCE

Accuracy: Input Accuracy + Output Accuracy

Input accuracy: ± 0.06 % of input range

Output accuracy: ± 0.04 % of output range

(Input and output accuracy is inversely proportional to the span)

Temp. coefficient: ± 0.015 %/°C (± 0.008 %/°F) of max. span

Response time: ≤ 1 sec. (0 - 90 %)

Line voltage effect: ± 0.1 % over voltage range

Insulation resistance: ≥ 100 M Ω with 500 V DC

Dielectric strength: 1500 V AC @ 1 minute

(input to output or power to ground)

500 V AC @ 1 minute (output to power)

CALCULATION EXAMPLES OF OVERALL ACCURACY

[Example] Input 4 - 20 mA, Output 4 - 20 mA

Input accuracy = Range 20 mA \div Span 16 mA \times 0.06 % = 0.075 %

Output accuracy = Range 20 mA \div Span 16mA \times 0.04 % = 0.05 %

Overall accuracy = 0.075 + 0.05 = 0.13 %

(Segment gain < 1. Multiply the calculated result by the gain when exceeding 1.

STANDARDS & APPROVALS

EU conformity:

EMC Directive

EMI EN 61000-6-4

EMS EN 61000-6-2

RoHS Directive

EN 50581

Approval:

UL/C-UL general safety requirements

(UL 61010-1, CAN/CSA-C22.2 No.1010-1)



EXTERNAL VIEW

■ FRONT VIEW

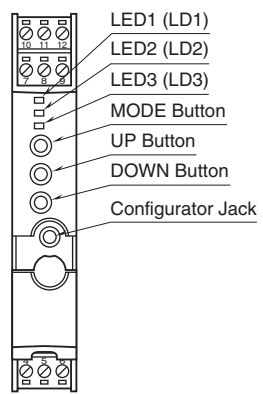

■ SIDE VIEW

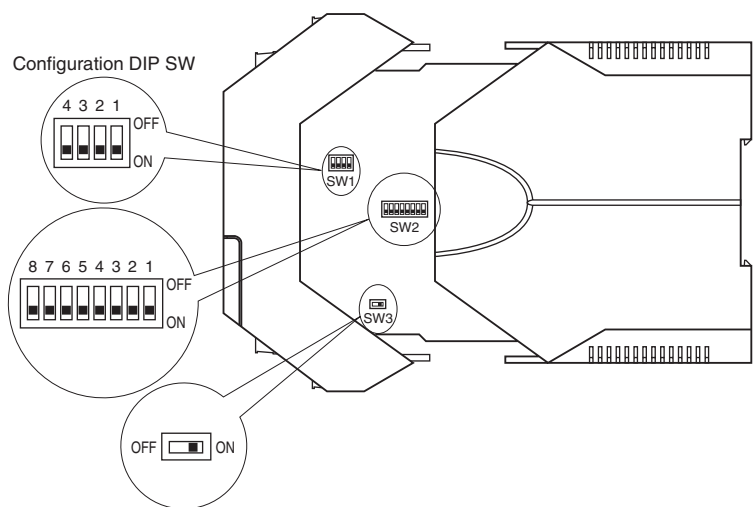

For M3LDY-R/A, the DIP switch setting is required to select output and input types before setting a precise output range using the PC configurator software.
 For detailed information on the configuration and calibration, refer to the instruction manual.

EXTERNAL DIMENSIONS & TERMINAL ASSIGNMENTS unit: mm (inch)

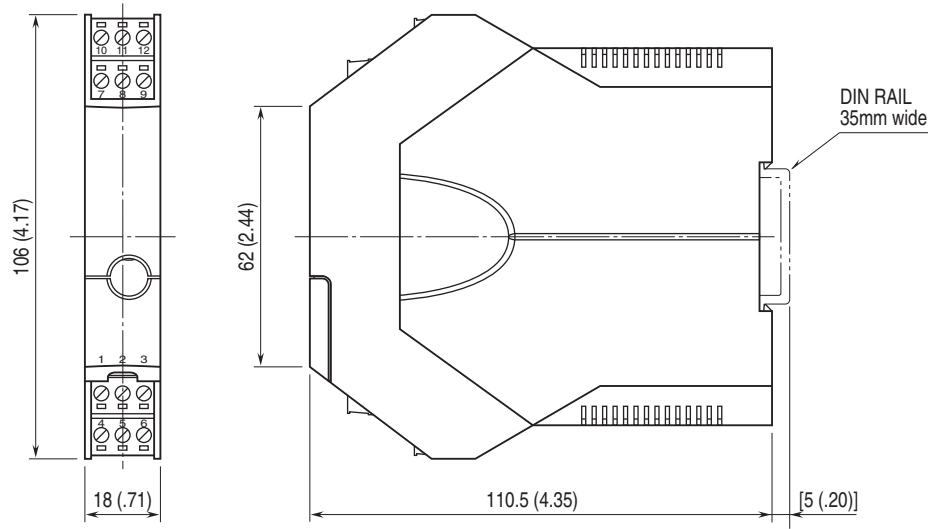

• When mounting, no extra space is needed between units.



SCHEMATIC CIRCUITRY & CONNECTION DIAGRAM

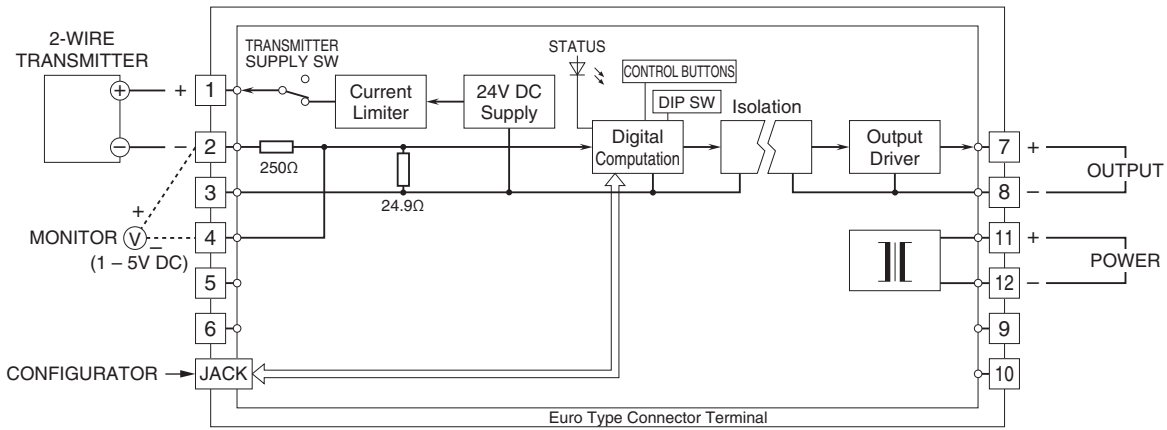

■ When Used as Isolator

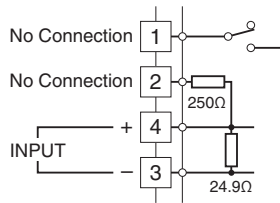

Specifications are subject to change without notice.

