

Digital precision vane anemometer

FVAD 15 -H120 / -H140 / -H220 / -H240 / -MK5 / -MK20 with ALMEMO® D6 plug



FVAD 15 -H120 / -H140



FVAD 15 -H220 / -H240



FVAD 15-MK5 / -MK20

Technical data and functions

- The precision probe heads and the sensor shaft are made of metal.
- The flow velocity is recorded with high accuracy.
- Every vane anemometer is adjusted individually. The multi-point adjustment is saved within the ALMEMO® D6 plug.
- Measurement operations carried out by a vane anemometer in air/gas are in practice nearly completely unaffected by environmental variables such as pressure, temperature, or humidity. The low dependence of the measured value on density can be compensated. The density of the gas can be programmed within the ALMEMO® D6 sensor menu on the ALMEMO® V7 device.
- The rugged construction is suitable for mobile as well as for stationary measurement operations.
- The ALMEMO® D6 plug measures the frequency signal of the vane with high resolution.
- One measuring channel is programmed (at our factory): flow velocity v (m/s).

Technical data:

Maximum resolution	0.01 m/s	Refresh rate	0.5 seconds for all channels
Nominal conditions	22 °C ±2 K, 1013 mbar	Averaging period	2 seconds, programmable from 2 to 100 s
Connection cable	permanently connected cable, 2 meters, with Lemo plug	Supply voltage	6 to 13 VDC
ALMEMO® adapter cable	Lemo coupling cable, 0.2 meters, with ALMEMO® D6 plug	Current consumption	8 mA
ALMEMO® D6 plug			
Frequency measurement	resolution 0.01 Hz	For more information about general features of the ALMEMO® D6 sensors, refer to page 01.05	
Multi-point adjustment	sensor specific, saved within the ALMEMO® D6 plug of the adapter cable		

Accessories

Order no.

Lemo extension cable, length = 5m, for FVAD 15-H120/-H140/-H220/-H240 /-MK5/-MK20 to extend the sensor cable

ZB9915VKLH05

ALMEMO® extension cable, length = 4m (see chapter 6)

ZA9060VK4

ALMEMO® extension cable, length = 5m (see chapter 6)

ZA9090VKC5

Extension set Ø 25mm, stainless steel, 3 tubes 350mm each, suitable for FVAD 15-H120/ -H140

ZV9915H25VR3

Extension set Ø 16mm, stainless steel, 3 tubes 350mm each, suitable for FVAD 15-H220/ -H240

ZV9915H16VR3

Tube adapter to impeller FVAD 15-HMKx Makro:

Ø 18 mm (impeller) to Ø 16 mm (extension tube), stainless steel, length 30 mm

ZV9915HMK

DAkkS or factory calibration KV90xx, air flow, for digital probe, see chapter Calibration certificates.
The DAkkS calibration fulfills the requirements of DIN EN ISO/IEC 17025 for test equipment.

Digital precision vane anemometer mini FVAD 15 -H120 / -H140

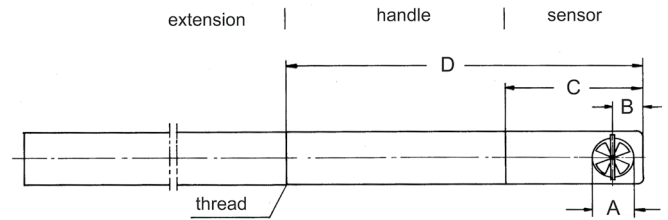
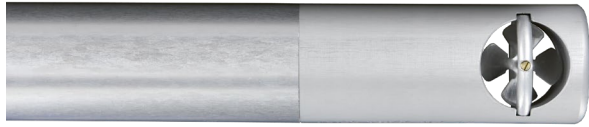

- The construction type as a cylindrical probe is optimized for safely introducing the probe in a flow channel. Probe head and handle have the same diameter.

Technical data:

Version:	mini, aluminum	Probe head:	aluminum, Ø 25 mm
Measured medium:	air/gas		dimensions C 60 mm
Operative range:	-20 to +125 °C (including cable)		dimensions A Ø 18.2 mm
Pressure resistance:	up to 6 bar overpressure		dimensions B 13.4 mm
Measuring range:	refer to Variants	Sensor shaft:	Aluminum, Ø 25 mm
Accuracy:	± (+0.5 % of final value sensor + 1.0 % of measured value) specific multi-point adjustment.	Sensor length:	dimensions D 170 mm
		Cable exit:	thread M 22 x 1.5
		Cable length:	2 m

Variants (including manufacturer's test certificate)

Digital precision vane anemometer for air/gas,
permanently connected cable, adapter cable with ALMEMO® D6 plug

Probe head MN20GA, measuring range of 0.3 to 20 m/s

Probe head MN40GA, measuring range of 0.4 to 40 m/s

Order no.

FVAD15H120

FVAD15H140

Digital precision vane anemometer micro FVAD 15H -H220 / -H240

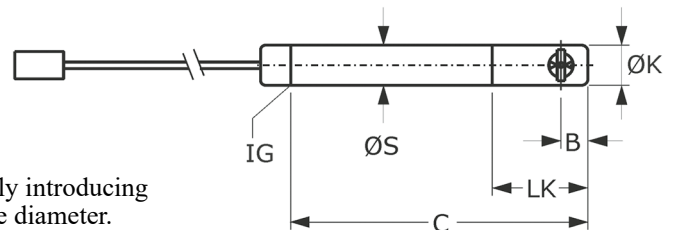

- The construction type as a cylindrical probe is optimized for safely introducing the probe in a flow channel. Probe head and handle have the same diameter.

Technical data:

Version:	micro, aluminum,	Probe head:	aluminum,
Measured medium:	air/gas		dimensions ØK Ø 16 mm
Operative range:	-20 to +125 °C (including cable)		dimensions LK 53 mm
Pressure resistance:	up to 3 bar overpressure		dimensions B 10,65 mm
Measuring range:	refer to Variants	Sensor shaft:	Aluminum,
Accuracy:	± (+0.5 % of final value sensor + 1.0 % of measured value) specific multi-point adjustment.		dimensions ØS Ø 16 mm
		Sensor length:	dimensions C 163 mm
		Cable exit:	dimensions IG thread M 14 x 1.5
		Cable length:	2 m

Variants (including manufacturer's test certificate)

Digital precision vane anemometer for air/gas,
permanently connected cable, adapter cable with ALMEMO® D6-plug.

Probe head MC20GA, measuring range of 0.6 to 20 m/s

Probe head MC40GA, measuring range of 0.7 to 40 m/s

Order no.

FVAD15H220

FVAD15H240

Digital precision vane anemometer makro FVAD 15 -HMK5 / -HMK20

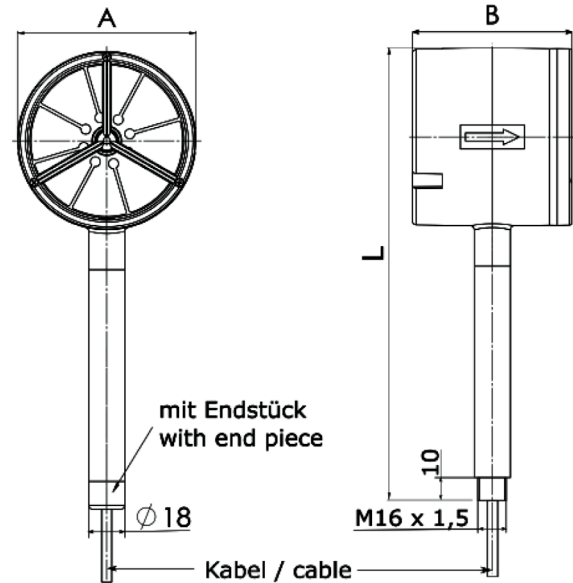

- Anemometer with T-measuring head.
- Large cross-sectional area.
- Small measuring range available.

- Low inclined flow sensitivity.
- For measuring medium air, pure gases or gas mixtures.

Applications

The digital precision vane anemometer with measuring head makro is used in a wide variety of applications to measure air velocity.

- Measurements on ventilation, air conditioning and filtration systems.
- Measurement of laminar flow and net measurements on large inlets and outlets.
- Verification of air movements in clean rooms.
- Control measurements on fume hoods of workbenches, workstations.
- Measurements in automotive engineering: during investigations in wind tunnels and in vehicle interiors.

Technical data:

Version:	makro, zinc alloy	Probe head:	zinc alloy
Measured medium:	air/gas	Impeller:	aluminum
Operative range:	-20 to +125 °C (including cable)		dimensions A Ø 90 mm
Pressure resistance:	atmospheric pressure		dimensions B 80 mm
Measuring range:	refer to Variants	Sensor shaft:	stainless steel, Ø 18 mm
Accuracy:	± (+0.5 % of final value sensor + 1.0 % of measured value)	Sensor length:	dimensions L 225 mm (without end piece)
	specific multi-point adjustment.	Cable exit:	thread M 22 x 1.5
		Cable length:	2 m
		Weight:	approx. 1kg (incl. cable)

Accessories

Carrying case for vane anemometer macro

Order no.

ZB9605TK

Variants (including manufacturer's test certificate)

Digital precision vane anemometer for air/gas, permanently connected cable, adapter cable with ALMEMO® D6 plug

Probe head MK5, measuring range of 0.15 to 5 m/s

Probe head MK20, measuring range of 0.25 to 20 m/s

Order no.

FVAD15HMK5

FVAD15HMK20

