

Tower Light Series

ETHERNET TOWER LIGHT

(small size, 60 mm dia., Modbus/TCP, 1 - 5 layers)

Functions & Features

- Lighting, blinking and buzzing available with PLC or PC via Modbus/TCP.

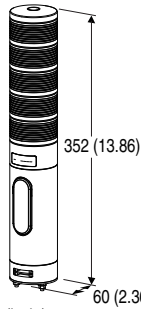

Lamp Layers	A
1	224 (8.82)
2	256 (10.08)
3	288 (11.34)
4	320 (12.60)
5	352 (13.86)

MODEL: IT60SRE-[1][2][3][4][5][6]D1-[7]

ORDERING INFORMATION

- Code number: IT60SRE-[1][2][3][4][5][6]D1-[7]
- Specify a code from below for each [1] through [7].
- (e.g. IT60SRE-5RYGBWD1-R)

[1] LAMP LAYERS

- 1: 1 layer
- 2: 2 layers
- 3: 3 layers
- 4: 4 layers
- 5: 5 layers

[2] LAMP 1 COLOR

(1st layer from the top)

- R: Red
- Y: Amber
- G: Green
- B: Blue
- W: White

[3] LAMP 2 COLOR

(2nd layer from the top)

- R: Red

Y: Amber

G: Green

B: Blue

W: White

N: None (not available when Lamp Layers selected are 2 - 5)

[4] LAMP 3 COLOR

(3rd layer from the top)

R: Red

Y: Amber

G: Green

B: Blue

W: White

N: None (not available when Lamp Layers selected are 3 - 5)

[5] LAMP 4 COLOR

(4th layer from the top)

R: Red

Y: Amber

G: Green

B: Blue

W: White

N: None (not available when Lamp Layers selected are 4 - 5)

[6] LAMP 5 COLOR

R: Red

Y: Amber

G: Green

B: Blue

W: White

N: None (not available when Lamp Layers selected are 5)

* Select "None" option for the layers other than the selected.

MOUNTING

D: Direct mounting

DESIGN TYPE

1: Type 1

(refer to outline dimensions)

[7] POWER INPUT

AC Power

M2: 100 - 240 V AC (Operational voltage range 85 - 264 V, 47 - 66 Hz)

DC Power

R: 24 V DC

(Operational voltage range 24 V ±10 %, ripple 10 %p-p max.)



RELATED PRODUCTS

- LAN cable (model: ITCA)
- Mounting Pole (model: ITPL)
- PC configurator software (model: ITCFG)

Functions are configurable using the PC Configurator Software.

Downloadable at M-System's web site.

Access to 192.168.0.1, the factory default setting, to set the device first time.

GENERAL SPECIFICATIONS

Degree of protection: IP 65, vertical mounting only (bottom connectors excluded)

Connection

Power: UL1007 AWG20

Network: RJ-45 Modular Jack

Housing material: Flame-resistant resin

Lens: Flame-resistant resin (transparent)

Isolation: Network to power input to FE1 (Functional Earth)

DIP SW Setting: Frequency of lamp blinking and buzzing discontinuance, buzzing volume level, output at connection failed and IP address (refer to the instruction manual)

Lamp: Red, amber, green, blue and white LEDs on/blinking (approx. 2 Hz, 10 Hz)

Indicator LEDs: Power, Run, Link, Link100, COL (5 LEDs) indicate the module's operating conditions. (Refer to the instruction manual)

Buzzing: Approx. 3.3 kHz

Interval: continuous/intermittent (approx. 2 Hz, 10 Hz)

COMMUNICATION

Communication Standard: IEEE 802.3u

Transmission: 10BASE-T, 100BASE-TX

Baud rate: 10/100 Mbps (Auto Negotiation function)

Protocol: Modbus/TCP

Data: RTU (Binary)

Max. number of socket connections: 2

Transmission media: 10BASE-T (STP, Category 5) 100BASE-TX (STP, Category 5e)

Max. length of fieldbus segment: 100 meters

IP address: 192.168.0.1 (factory setting);
Selectable with PC Configurator Software

Port No.: 502

Ethernet indicator LED: Link, Link100, COL

INSTALLATION

Power Consumption

•AC:

Approx. 7.5 VA at 100 V with max. load

Approx. 10 VA at 200 V with max. load

Approx. 11 VA at 240 V with max. load

•DC: Approx. 5 W

Operating temperature: -10 to +55°C (14 to 131°F)

Operating humidity: 30 to 90 %RH (non-condensing)

Atmosphere: No corrosive gas

Mounting: Direct mounting

Mounting direction: Vertical

Weight: 750 g (1.65 lb)

PERFORMANCE

Insulation resistance: $\geq 100 \text{ M}\Omega$ with 500 V DC

Dielectric strength: 1500 V AC @ 1 minute
(network to power to FE1)

STANDARDS & APPROVALS

Refer to the manuals to comply with the standards.

CE conformity:

EMC Directive (2004/108/EC)

EN 60947-5-1: 2004/A1: 2009

Low Voltage Directive (2006/95/EC)

EN 60947-5-1: 2004/A1: 2009

24 V DC power

Installation Category III

Pollution Degree 3

100 - 240 V AC power

Installation Category II

Pollution Degree 2

Input to power: Reinforced insulation (300 V)



EXTERNAL VIEW

■ FRONT VIEW (with the cover open)

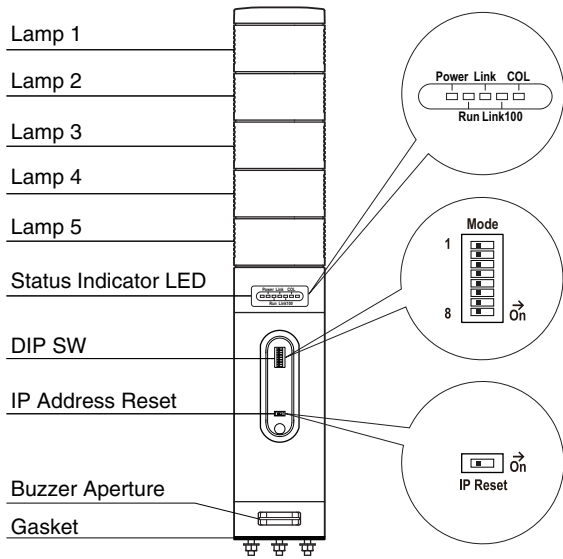

■ BOTTOM VIEW

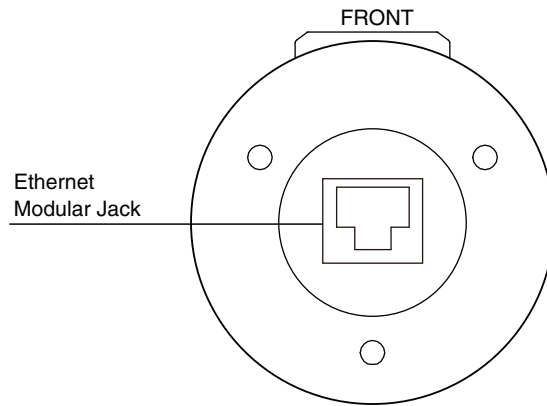

DIMENSIONS unit: mm

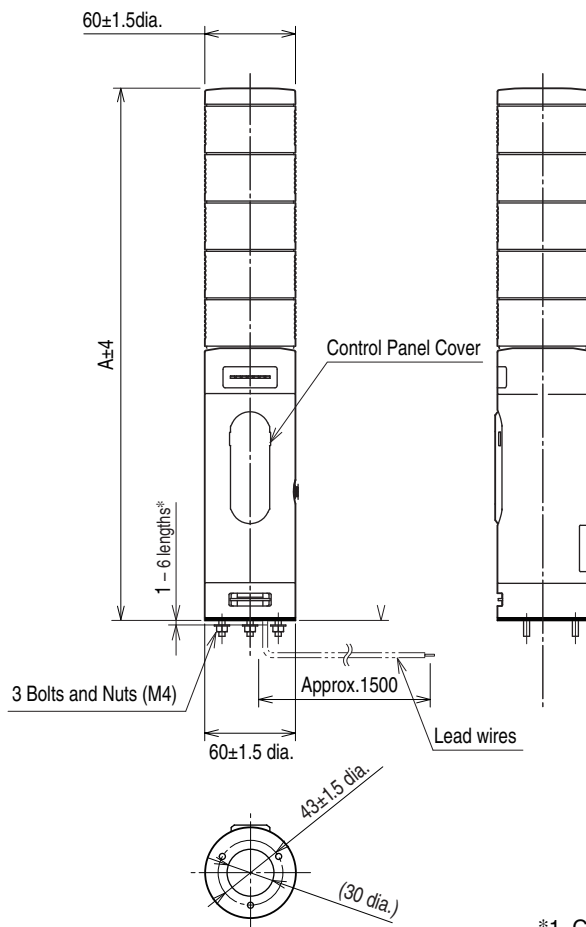

Lamp Layers	A
1	224
2	256
3	288
4	320
5	352

*1. Consult M-System for other bolt length.



MOUNTING REQUIREMENTS unit: mm

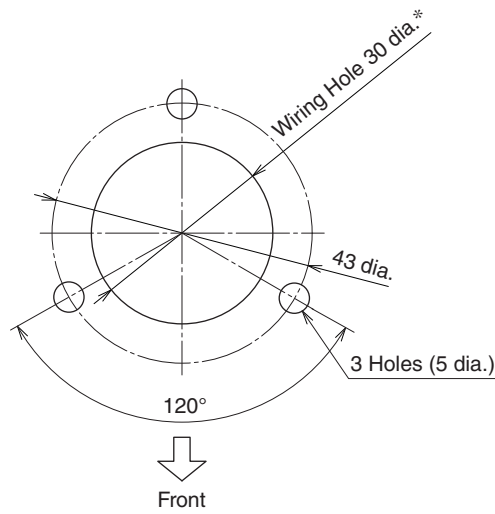

*Protect wires to prevent scratching them at the edge of the compartment.

SCHEMATIC CIRCUITRY & CONNECTION DIAGRAM

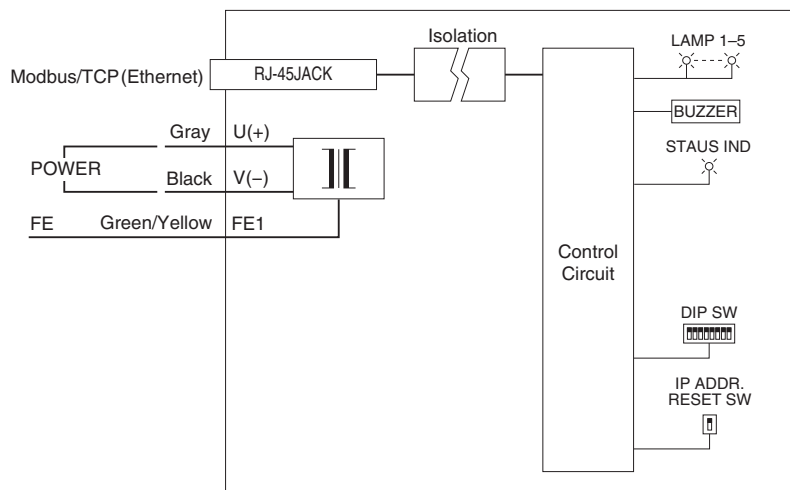

Specifications are subject to change without notice.