

Tower Light Series

CC-Link TOWER LIGHT

(small size, 50 mm dia., 1 - 5 layers)

Functions & Features

- Lighting, blinking and buzzing are controllable with PLC.
- Separable tension clamp terminal

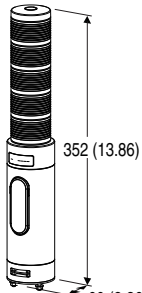

| Lamp Layers | A |
|-------------|-------------|
| 1 | 224 (8.82) |
| 2 | 256 (10.08) |
| 3 | 288 (11.34) |
| 4 | 320 (12.60) |
| 5 | 352 (13.86) |

MODEL: IT50SRC-[1][2][3][4][5][6]D1-[7]

ORDERING INFORMATION

- Code number: IT50SRC-[1][2][3][4][5][6]D1-[7]
- Specify a code from below for each [1] through [7].
(e.g. IT50SRC-5RYGBWD1-M2)

[1] LAMP LAYERS

- 1: 1 layer
- 2: 2 layers
- 3: 3 layers
- 4: 4 layers
- 5: 5 layers

[2] LAMP 1 COLOR

(1st layer from the top)

- R: Red
- Y: Amber
- G: Green
- B: Blue
- W: White

[3] LAMP 2 COLOR

(2nd layer from the top)

- R: Red
- Y: Amber

G: Green

B: Blue

W: White

N: None (not available when Lamp Layers selected are 2 - 5)

[4] LAMP 3 COLOR

(3rd layer from the top)

R: Red

Y: Amber

G: Green

B: Blue

W: White

N: None (not available when Lamp Layers selected are 3 - 5)

[5] LAMP 4 COLOR

(4th layer from the top)

R: Red

Y: Amber

G: Green

B: Blue

W: White

N: None (not available when Lamp Layers selected are 4 - 5)

[6] LAMP 5 COLOR

R: Red

Y: Amber

G: Green

B: Blue

W: White

N: None (not available when Lamp Layers selected are 5)

* Select "None" option for the layers other than the selected.

MOUNTING

D: Direct mounting

DESIGN TYPE

1: Type 1

[7] POWER INPUT

AC Power

M2: 100 - 240 V AC (Operational voltage range 85 - 264 V, 47 - 66 Hz)

DC Power

R: 24 V DC

(Operational voltage range 24 V ±10 %, ripple 10 %p-p max.)



RELATED PRODUCTS

- Mounting Pole (model: ITPL)

GENERAL SPECIFICATIONS

Degree of protection: IP 65, vertical mounting only (bottom connectors excluded)

Connection

Power input: UL1007 AWG20

CC-Link: Separable tension clamp terminal

Applicable wire size: 0.2 to 1.5 mm², stripped length 10 mm

Recommended solderless terminal:

AI0,5-10WH 0.5mm² (Phoenix Contact)

AI0,75-10GY 0.75mm² (Phoenix Contact)

Housing material: Flame-resistant resin

Lens: Flame-resistant resin (transparent)

Isolation: Network to power input to FE1 (Functional Earth)

DIP SW Setting: Frequency of lamp blinking and buzzing discontinuance, buzzing volume level and output at connection failed. (refer to the instruction manual)

Lamp: Red, amber, green, blue and white LEDs on/blinking (approx. 2 Hz, 10 Hz)

Indicator LEDs: Power, Run, Error, SD and RD (5 LEDs) indicate the module's operating conditions. (Refer to the instruction manual)

Buzzing: Approx. 3.3 kHz

Interval: continuous/intermittent (approx. 2 Hz, 10 Hz)

CC-Link COMMUNICATION

Protocol: CC-Link V1.10

Device type: Remote I/O station

Station No. setting: Rotary switch; 1 - 64

Required node: 1

Baud rate setting: Rotary switch

156kbps, 625kbps, 2.5Mbps, 5Mbps, 10Mbps

Cable for comm. link: Specified by Mitsubishi Electric

Terminating resistor: Built-in (Selected with the DIP SW)

INSTALLATION

Power consumption

•AC: Approx. 5.5 VA at 100 V

Approx. 7 VA at 200 V

Approx. 8 VA at 240 V

•DC: Approx. 3 W

Operating temperature: -10 to +55°C (14 to 131°F)

Operating humidity: 30 to 90 %RH (non-condensing)

Atmosphere: No corrosive gas

Mounting: Direct mounting

Mounting direction: Vertical

Weight: 700 g (1.5 lb)

PERFORMANCE

Insulation resistance: $\geq 100 \text{ M}\Omega$ with 500 V DC

Dielectric strength: 1500 V AC @ 1 minute
(network to power to FE1)

STANDARDS & APPROVALS

CE conformity:

EMC Directive (2004/108/EC)

EN 60947-5-1: 2004/A1: 2009

Low Voltage Directive (2006/95/EC)

EN 60947-5-1: 2004/A1: 2009

24 V DC power

Installation Category III

Pollution Degree 3

100 - 240 V AC power

Installation Category II

Pollution Degree 2

Input to power: Reinforced insulation (300 V)

Protection against access to the terminal blocks:

Finger protection (VDE 0660-514)



EXTERNAL VIEW

■ FRONT VIEW (with the cover open)

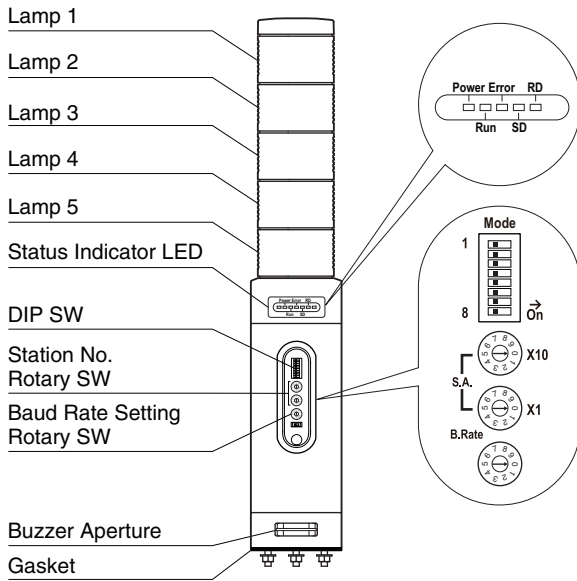

■ BOTTOM VIEW

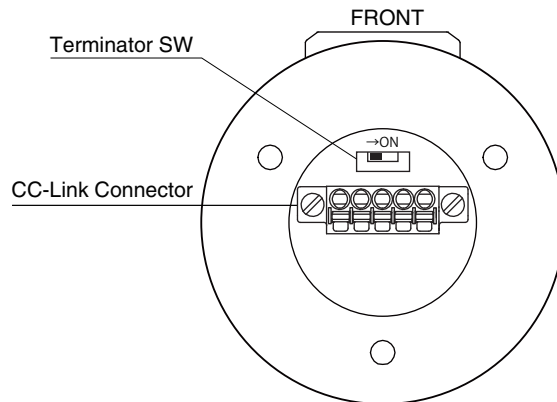

TERMINAL ASSIGNMENTS

■ CC-Link CONNECTOR



| | | |
|---|-----|--------|
| 1 | FE | FE |
| 2 | SLD | Shield |
| 3 | DG | Yellow |
| 4 | DB | White |
| 5 | DA | Blue |

DIMENSIONS unit: mm

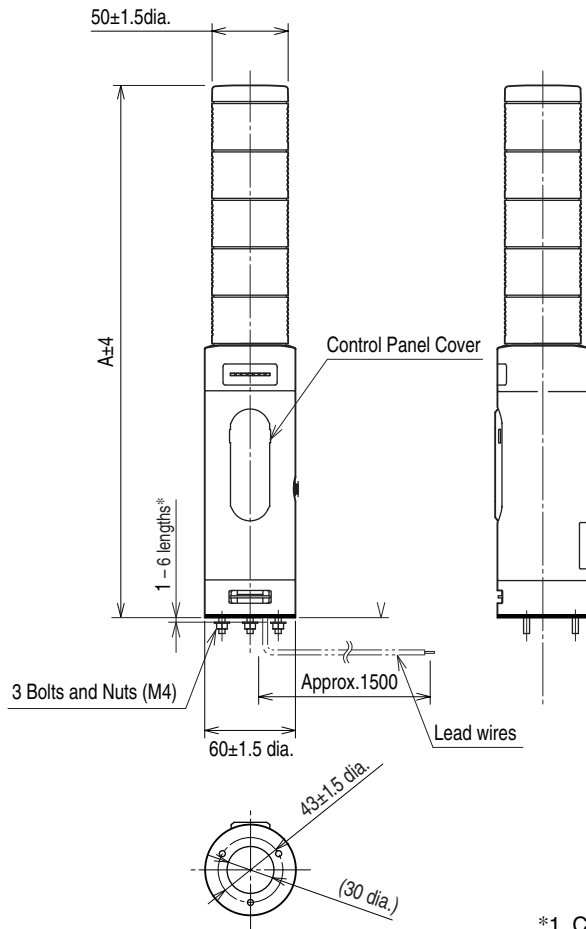

| Lamp Layers | A |
|-------------|-----|
| 1 | 224 |
| 2 | 256 |
| 3 | 288 |
| 4 | 320 |
| 5 | 352 |

*1. Consult M-System for other bolt length.

MOUNTING REQUIREMENTS unit: mm

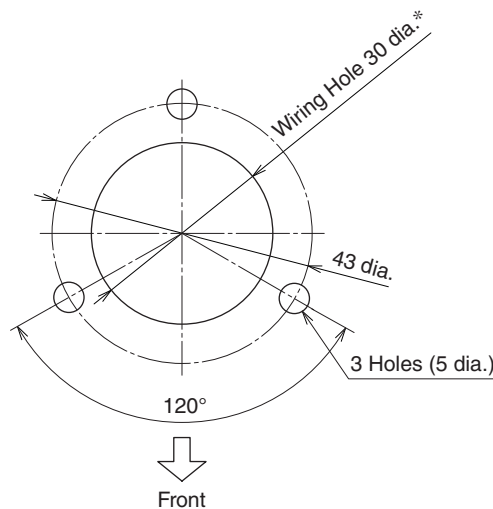

*Protect wires to prevent scratching them at the edge of the compartment.



SCHEMATIC CIRCUITRY & CONNECTION DIAGRAM

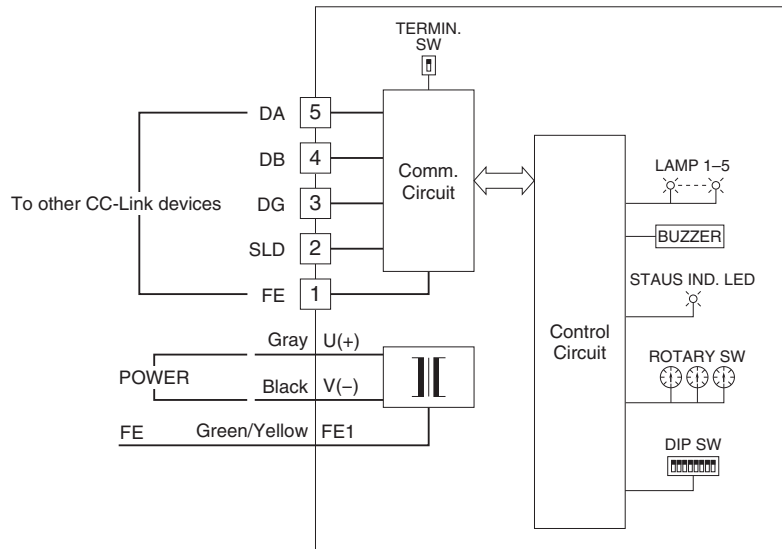

Specifications are subject to change without notice.

