

## Remote I/O R3 Series

### POTENTIOMETER INPUT MODULE

(8 points, isolated)

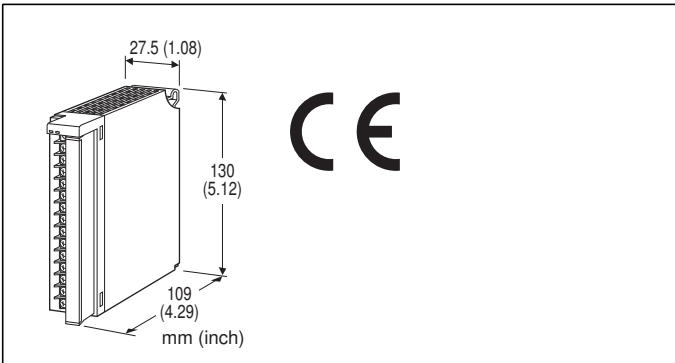

### MODEL: R3-MS8[1][2]

#### ORDERING INFORMATION

- Code number: R3-MS8[1][2]

Specify a code from below for each [1] and [2].

(e.g. R3-MS8W/CE/Q)

- Specify the specification for option code /Q  
(e.g. /C01)

#### INPUT

Total resistance 500 Ω - 100 kΩ

#### NO. OF CHANNELS

8: 8

#### [1] COMMUNICATION MODE

S: Single

W: Dual

#### [2] OPTIONS (multiple selections)

##### Standards & Approvals

blank: Without CE

/CE: CE marking

##### Other Options

blank: none

/Q: Option other than the above (specify the specification)

#### SPECIFICATIONS OF OPTION: Q

**COATING (For the detail, refer to M-System's web site.)**

/C01: Silicone coating

/C02: Polyurethane coating

/C03: Rubber coating

#### GENERAL SPECIFICATIONS

##### Connection

**Internal bus:** Via the Installation Base (model: R3-BSx)

**Input:** M3 separable screw terminal (torque 0.5 N·m)

**Internal power:** Via the Installation Base (model: R3-BSx)

**Screw terminal:** Nickel-plated steel

**Isolation:** Input 1 to input 2 to input 3 to input 4 to input 5 to input 6 to input 7 to input 8 to internal bus or internal power

**Conversion rate:** Selectable with the side DIP SW

**RUN indicator:** Bi-color (red/green) LED;

Red when the bus A operates normally;

Green when the bus B operates normally;

Amber when both buses operate normally.

**ERR indicator:** Bi-color (red/green) LED;

Red with the input abnormality;

Green in normal operating conditions.

#### INPUT SPECIFICATIONS

**Minimum span:** 50 % of the total resistance range

**Excitation:** Approx. 0.5 V DC

#### INSTALLATION

**Operating temperature:** -10 to +55°C (14 to 131°F)

**Operating humidity:** 30 to 90 %RH (non-condensing)

**Atmosphere:** No corrosive gas or heavy dust

**Mounting:** Installation Base (model: R3-BSx)

**Weight:** 250 g (0.55 lb)

#### PERFORMANCE

**Conversion accuracy:** Refer to the table at the end of this section.

The resolution, conversion accuracy and temperature coefficient are defined against the potentiometer's total resistance. If the actual resistance range (between the zero and span positions) is narrower than the total resistance, the values change in proportion. Using at least 50 % of the total resistance is basically recommended.

**Conversion rate:** 160 / 80 / 40 / 20 msec. selectable

**Data range:** 0 - 10000

**Data allocation:** 8

**Current consumption:** Approx. 100 mA

**Temp. coefficient:** ±0.015 % /°C

The resolution, conversion accuracy and temperature coefficient are defined against the potentiometer's total resistance. If the actual resistance range (between the zero and span positions) is narrower than the total resistance, the values change in proportion. Using at least 50 % of the total resistance is basically recommended.

**Insulation resistance:** ≥ 100 MΩ with 500 V DC

**Dielectric strength:** 1000 V AC @ 1 minute (input 1 to input 2 to input 3 to input 4 to input 5 to input 6 to input 7 to



input 8 to internal bus or internal power)  
 2000 V AC @ 1 minute (power input to FG; isolated on the power supply module)

### Conversion accuracy

	CONVERSION RATE			
	160 msec.	80 msec.	40 msec.	20 msec.
Resolution	1/10000	1/5000	1/2500	1/1250
Accuracy	±0.05%	±0.1%	±0.2%	±0.4%

## STANDARDS & APPROVALS

### CE conformity:

EMC Directive (2004/108/EC)

EMI EN 61000-6-4: 2007/A1: 2011

EMS EN 61000-6-2: 2005

## EXTERNAL VIEW

### ■ SIDE VIEW

### ■ FRONT VIEW

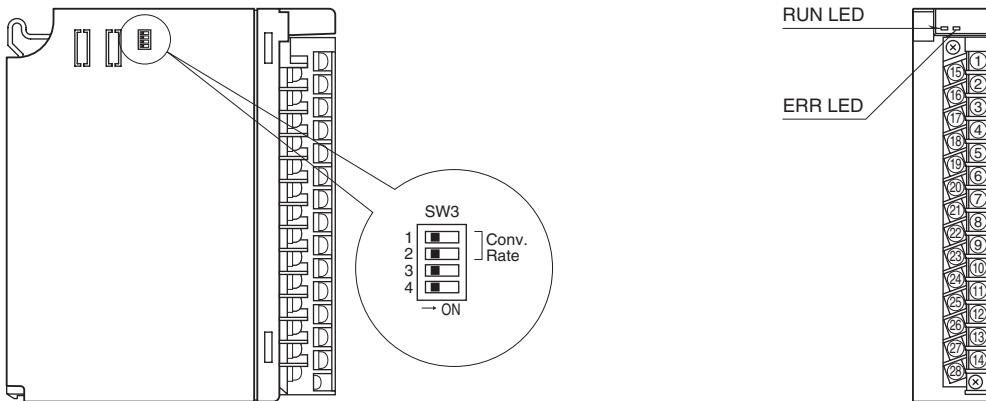

## EXTERNAL DIMENSIONS & TERMINAL ASSIGNMENTS unit: mm (inch)

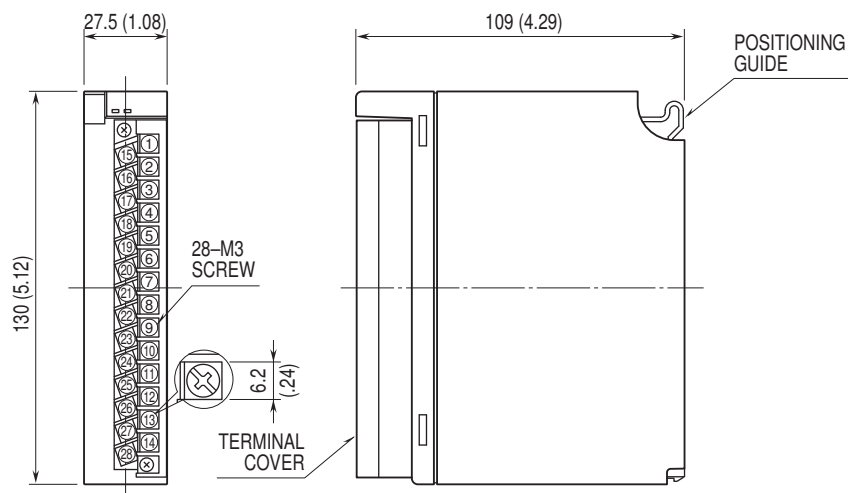

## SCHEMATIC CIRCUITRY & CONNECTION DIAGRAM

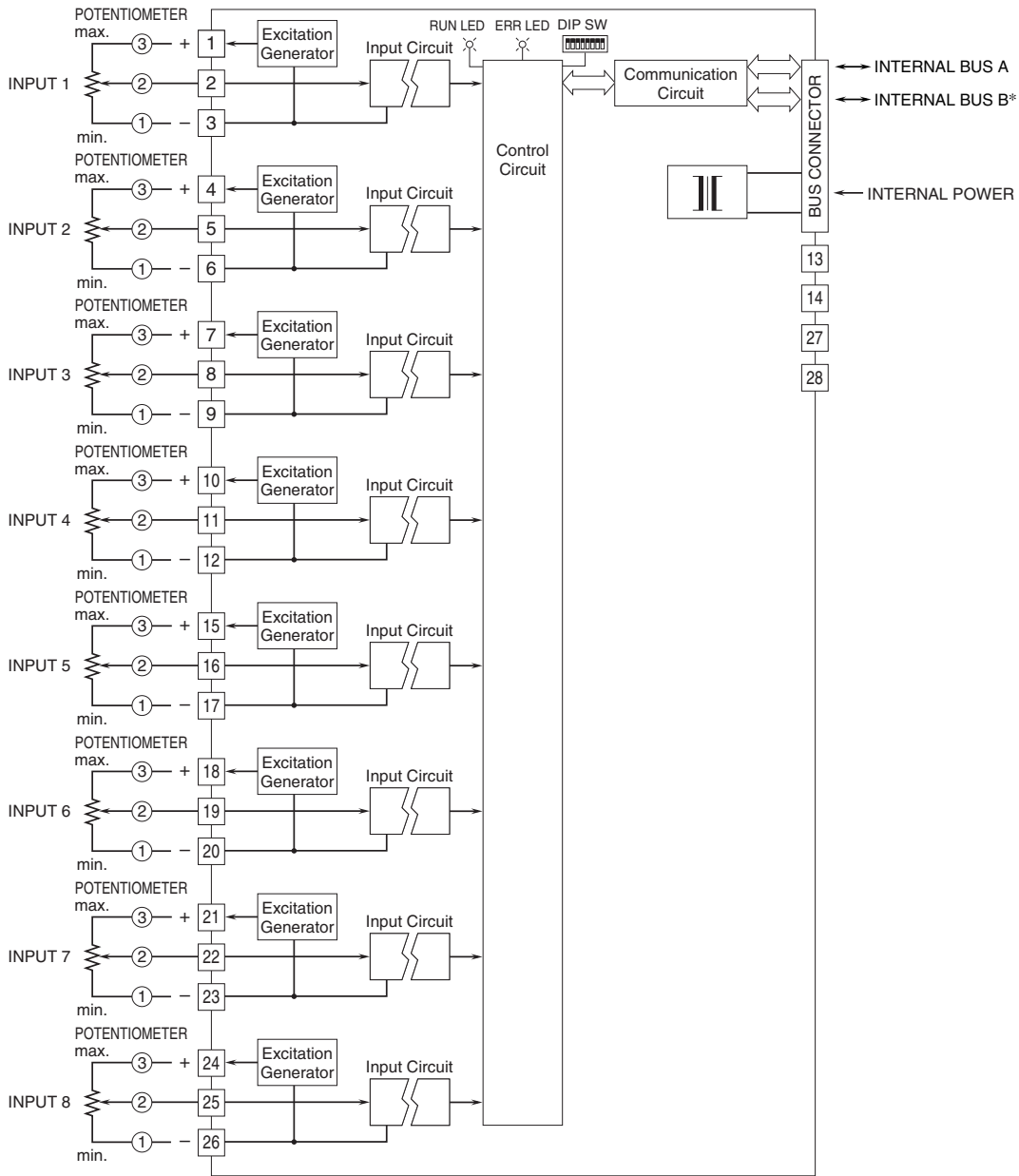

\*For dual redundant communication.

### • Unused Input Channels

Close across the unused input terminals as shown below.

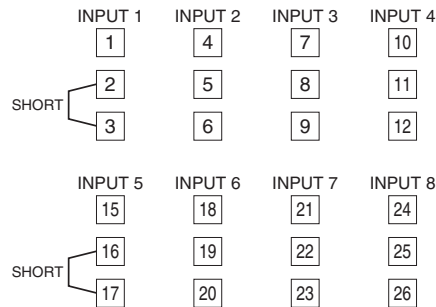

The input will become unstable if unused channels are left open.

Unused channels can be specified and set so on the PC Configurator Software (model: R3CON) without needing to short at the field terminals.





Specifications are subject to change without notice.



**幸託有限公司**  
XIN TOP CORPORATION

TEL : (02)2598-1199  
FAX : (02)2596-2331

E-mail : [info@xintop.com](mailto:info@xintop.com)  
Website : [www.xintop.com](http://www.xintop.com)