

Remote I/O R3 Series

THERMOCOUPLE INPUT ALARM MODULE

(4 points, isolated)

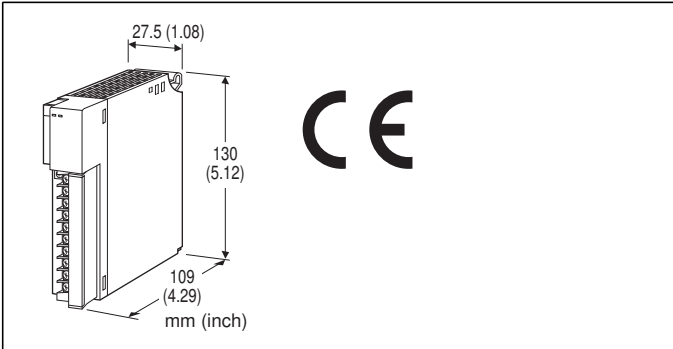

MODEL: R3-AT4[1][2]

ORDERING INFORMATION

- Code number: R3-AT4[1][2]
- Specify a code from below for each [1] and [2]. (e.g. R3-AT4W/CE/Q)
- Specify the specification for option code /Q (e.g. /C01)

NO. OF CHANNELS

4: 4

[1] COMMUNICATION MODE

S: Single

W: Dual

[2] OPTIONS (multiple selections)

Standards & Approvals

blank: Without CE

/CE: CE marking

Other Options

blank: none

/Q: Option other than the above (specify the specification)

SPECIFICATIONS OF OPTION: Q

COATING (For the detail, refer to M-System's web site.)

/C01: Silicone coating

/C02: Polyurethane coating

/C03: Rubber coating

GENERAL SPECIFICATIONS

Connection

Internal bus: Via the Installation Base (model: R3-BSx)

Input: M3 separable screw terminal (torque 0.5 N·m)

Internal power: Via the Installation Base (model: R3-BSx)

Screw terminal: Nickel-plated steel

Isolation: Input 1 to input 2 to input 3 to input 4 to internal bus or internal power

Sensor type: Selectable with the side DIP SW

Temperature unit: °C, °F or absolute temperature selectable with the side DIP SW

Conversion rate: Selectable with the side DIP SW

Burnout detection: Upscale or downscale selectable with the side DIP SW

Linearization: Standard

Cold junction compensation: CJC sensor attached to the input terminals

RUN indicator: Bi-color (red/green) LED;

Red when the bus A operates normally;

Green when the bus B operates normally;

Amber when both buses operate normally.

ERR indicator: Bi-color (red/green) LED;

Red with the burnout; Green in normal operating conditions.

INPUT SPECIFICATIONS

Input resistance: 30 kΩ min.

Burnout sensing: 0.1 μA

Temperature range

T/C	°C	
	USABLE RANGE	CONFORMANCE RANGE
K (CA)	-270 to +1370	-150 to +1370
E (CRC)	-270 to +1000	-170 to +1000
J (IC)	-210 to +1200	-180 to +1200
T (CC)	-270 to +400	-170 to +400
B (RH)	100 to 1820	400 to 1760
R	-50 to +1768	200 to 1760
S	-50 to +1768	0 to 1760
C (WRe 5-26)	0 to 2315	0 to 2315
N	-270 to +1300	-130 to +1300
U	-200 to +600	-200 to +600
L	-200 to +900	-200 to +900
P (Platinel II)	0 to 1395	0 to 1395
(PR)	0 to 1760	0 to 1760
T/C	°F	
	USABLE RANGE	CONFORMANCE RANGE
K (CA)	-454 to +2498	-238 to +2498
E (CRC)	-454 to +1832	-274 to +1832
J (IC)	-346 to +2192	-292 to +2192
T (CC)	-454 to +752	-274 to +752
B (RH)	212 to 3308	752 to 3200
R	-58 to +3214	392 to 3200
S	-58 to +3214	32 to 3200
C (WRe 5-26)	32 to 4199	32 to 4199
N	-454 to +2372	-202 to +2372
U	-328 to +1112	-328 to +1112
L	-328 to +1652	-328 to +1652
P (Platinel II)	32 to 2543	32 to 2543
(PR)	32 to 3200	32 to 3200



INSTALLATION

Operating temperature: -10 to +55°C (14 to 131°F)
Operating humidity: 30 to 90 %RH (non-condensing)
Atmosphere: No corrosive gas or heavy dust
Mounting: Installation Base (model: R3-BSx)
Weight: 200 g (0.44 lb)

PERFORMANCE

Conversion accuracy: $\pm 1.0^{\circ}\text{C}$ ($\pm 1.8^{\circ}\text{F}$) except $\pm 2.0^{\circ}\text{C}$ ($\pm 3.6^{\circ}\text{F}$) for B, R, S, C, PR
Conversion rate: 250 msec. or 1 sec. selectable
Data allocation: 1
Current consumption: 70 mA
Cold junction compensation error:
 $\pm 1.0^{\circ}\text{C}$ max. (at $25^{\circ}\text{C} \pm 10^{\circ}\text{C}$)
 $\pm 1.8^{\circ}\text{F}$ max. (at $77^{\circ}\text{F} \pm 18^{\circ}\text{F}$)
($\pm 1.5^{\circ}\text{C}$ or $\pm 2.7^{\circ}\text{F}$ for R, S, PR)
Temp. coefficient: $\pm 0.015\%$ / $^{\circ}\text{C}$ ($\pm 0.008\%$ / $^{\circ}\text{F}$)
Burnout response time: ≤ 2 sec.
Insulation resistance: $\geq 100\ \text{M}\Omega$ with 500 V DC
Dielectric strength: 1500 V AC @ 1 minute (input 1 to input 2 to input 3 to input 4 to internal bus or internal power)
2000 V AC @ 1 minute (power input to FG; isolated on the power supply module)

STANDARDS & APPROVALS

CE conformity:
EMC Directive (2004/108/EC)
EMI EN 61000-6-4: 2007/A1: 2011
EMS EN 61000-6-2: 2005

ALARM SETTING

The following parameters are programmable using the PC Configurator Software (model: R3CON).

■ALARM TRIP POINT

(-270.0 to +2400.0°C or -454 to +4352°F)

Four alarm setpoints are selectable per each input.

■ALARM TYPE (High or Low)

High or Low alarm is selectable for each alarm trip point.

High alarm: An alarm is set when the input signal goes above the setpoint.

Low alarm: An alarm is set when the input signal goes below the setpoint.

■DEADBAND (HYSTERESIS)

(0.0 to 900.0°C or 0 to 1620°F; factory set to 10.0°C or 100°F)

Deadband (deviation between the points where the alarm is set and reset) is selectable for each alarm trip point.

■ALARM ON DELAY TIME

(0.0 to 99.0 seconds; factory set to 1.0)

The alarm output is set when the preset time elapses after

the input has entered in the alarm range.

This setting is common to all four points.

■POWER ON DELAY TIME

(0.0 to 99.0 sec.; factory set to 5.0)

The alarm output start functioning in the preset time after the power has been turned on.

This setting is common to all four points.

■ALARM HOLD TIME

(0.0 to 99.0 seconds; factory set to 1.0)

The alarm output is held for the preset time even if it is reset in shorter time.

This setting is common to all four points.



EXTERNAL VIEW

■ FRONT VIEW

■ SIDE VIEW

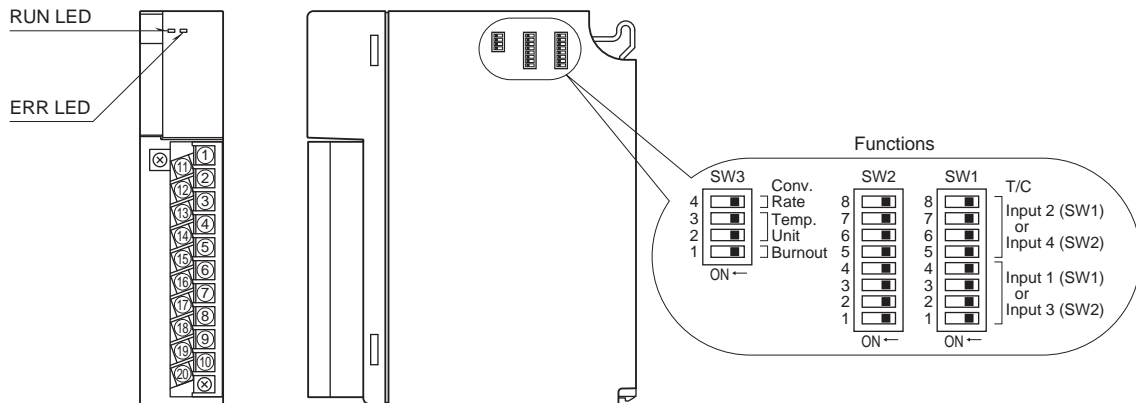

OUTPUT DATA DESCRIPTIONS

Four alarm setpoints are selectable per each input. One (1) word (16 bit) data is transmitted to the PLC or the host device via the R3 network module.

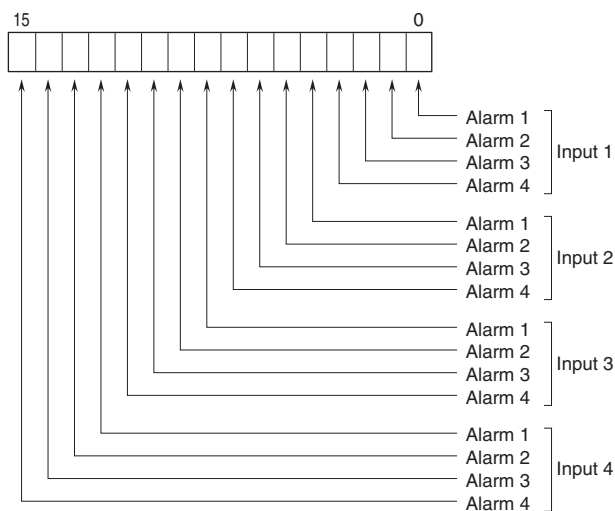

EXTERNAL DIMENSIONS & TERMINAL ASSIGNMENTS unit: mm (inch)

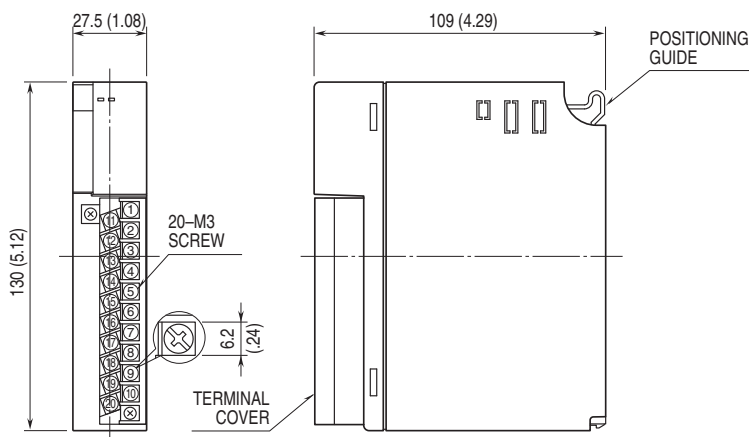

SCHEMATIC CIRCUITRY & CONNECTION DIAGRAM

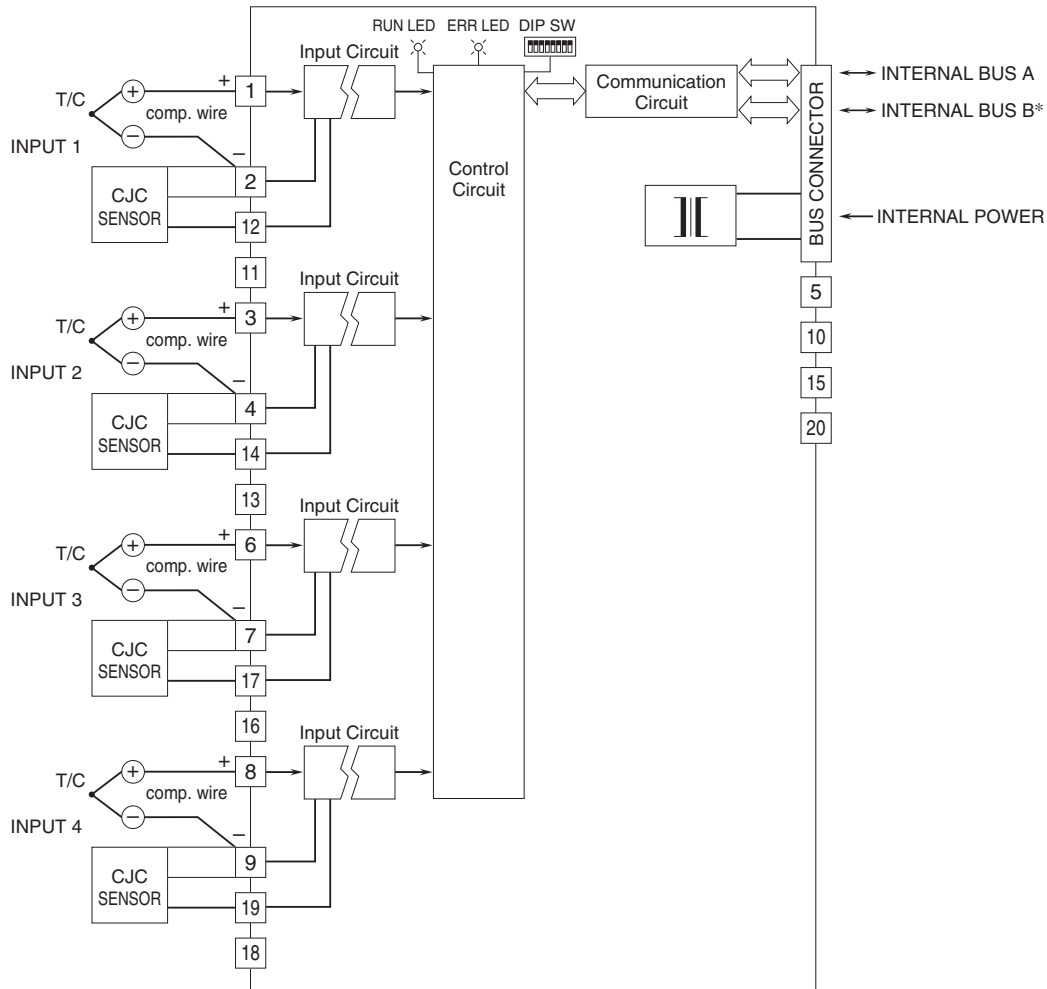

*For dual redundant communication.

• Unused Input Channels

Close across the unused input terminals as shown below.
(Choose K (CA) thermocouple for unused channels.)

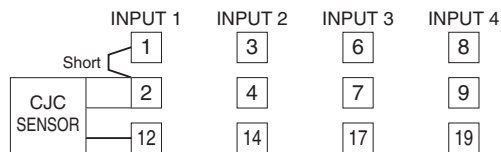

Unused channels left open are equal to the burnout, which turns the red ERR LED on and sets a burnout flag at the PLC or the host device.

Shortcircuiting the terminals means approximate room temperature. An alarm setpoint must be set to a value that does not trip an unwanted alarm.

Unused channels can be specified and set so on the PC Configurator Software (model: R3CON) without needing to short at the field terminals.



Specifications are subject to change without notice.



幸託有限公司
XIN TOP CORPORATION

TEL : (02)2598-1199
FAX : (02)2596-2331

E-mail : info@xintop.com
Website : www.xintop.com