

Remote I/O R3 Series

DC CURRENT INPUT ALARM MODULE

(4 points, isolated)

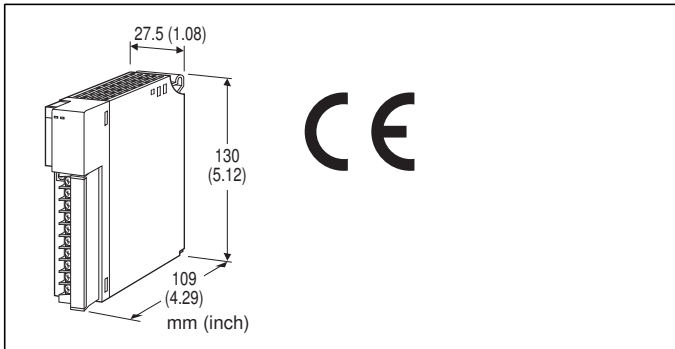

MODEL: R3-AS4[1][2]

ORDERING INFORMATION

- Code number: R3-AS4[1][2]
- Specify a code from below for each [1] and [2]. (e.g. R3-AS4W/CE/Q)
- Specify the specification for option code /Q (e.g. /C01)

NO. OF CHANNELS

4: 4

[1] COMMUNICATION MODE

S: Single

W: Dual

[2] OPTIONS (multiple selections)

Standards & Approvals

blank: Without CE

/CE: CE marking

Other Options

blank: none

/Q: Option other than the above (specify the specification)

SPECIFICATIONS OF OPTION: Q

COATING (For the detail, refer to M-System's web site.)

/C01: Silicone coating

/C02: Polyurethane coating

/C03: Rubber coating

CAUTION

■UNUSED INPUT CHANNELS

Set the unused input channels to ± 20 mA or 0 - 20 mA

range. Unused channels left open with 4 - 20 mA setting are equal to the input lower than -15 %, which sets a data abnormality at the PLC or the host device.

Open circuit with the input range set to ± 20 mA means 50 % of the full-scale. An alarm setpoint must be set to a value that does not trip an unwanted alarm.

Unused channels can be specified and set so on the PC Configurator Software (model: R3CON) without needing the above mentioned setting.

GENERAL SPECIFICATIONS

Connection

Internal bus: Via the Installation Base (model: R3-BSx)

Input: M3 separable screw terminal (torque 0.5 N·m)

Internal power: Via the Installation Base (model: R3-BSx)

Screw terminal: Nickel-plated steel

Isolation: Input 1 to input 2 to input 3 to input 4 to internal bus or internal power

Input range: Selectable with the side DIP SW

Conversion rate: Selectable with the side DIP SW

RUN indicator: Bi-color (red/green) LED;

Red when the bus A operates normally;

Green when the bus B operates normally;

Amber when both buses operate normally.

ERR indicator: Bi-color (red/green) LED;

Red with the input circuit abnormality (AD converter response failure);

Green in normal operating conditions.

INPUT SPECIFICATIONS

■ **DC Current:** -20 - +20 mA, 0 - 20 mA, 4 - 20 mA DC

Input resistance: 20 Ω resistor incorporated

INSTALLATION

Operating temperature: -10 to +55°C (14 to 131°F)

Operating humidity: 30 to 90 %RH (non-condensing)

Atmosphere: No corrosive gas or heavy dust

Mounting: Installation Base (model: R3-BSx)

Weight: 200 g (0.44 lb)

PERFORMANCE

Conversion accuracy: Refer to the table at the end of this section.

Conversion rate: 80 / 40 / 20 / 10 msec. selectable

Data allocation: 1

Current consumption: 60 mA

Temp. coefficient: ± 0.03 %/°C (± 0.02 %/°F)

Insulation resistance: ≥ 100 M Ω with 500 V DC

Dielectric strength: 1500 V AC @ 1 minute (input 1 to input 2 to input 3 to input 4 to internal bus or internal power)



2000 V AC @ 1 minute (power input to FG; isolated on the power supply module)

RANGE	RATE			
	80 msec.	40 msec.	20 msec.	10 msec.
-20 – +20 mA	±0.05%	±0.1%	±0.2%	±0.4%
0 – 20 mA	±0.1%	±0.2%	±0.4%	±0.8%
4 – 20 mA	±0.1%	±0.2%	±0.4%	±0.8%

STANDARDS & APPROVALS

CE conformity:

EMC Directive (2004/108/EC)

EMI EN 61000-6-4: 2007/A1: 2011

EMS EN 61000-6-2: 2005

ALARM SETTING

The following parameters are programmable using the PC Configurator Software (model: R3CON).

■ALARM TRIP POINT (-15.00 to +115.00 %)

Four alarm setpoints are selectable per each input.

■ALARM TYPE (High or Low)

High or Low alarm is selectable for each alarm trip point.

High alarm: An alarm is set when the input signal goes above the setpoint.

Low alarm: An alarm is set when the input signal goes below the setpoint.

■DEADBAND (HYSTERESIS)

(0.00 to 100.00 %; factory set to 5.00)

Deadband (deviation between the points where the alarm is set and reset) is selectable for each alarm trip point.

■ALARM ON DELAY TIME

(0.0 to 99.0 seconds; factory set to 1.0)

The alarm output is set when the preset time elapses after the input has entered in the alarm range.

This setting is common to all four points.

■POWER ON DELAY TIME

(0.0 to 99.0 sec.; factory set to 5.0)

The alarm output start functioning in the preset time after the power has been turned on.

This setting is common to all four points.

■ALARM HOLD TIME

(0.0 to 99.0 seconds; factory set to 1.0)

The alarm output is held for the preset time even if it is reset in shorter time.

This setting is common to all four points.



EXTERNAL VIEW

■ FRONT VIEW

■ SIDE VIEW

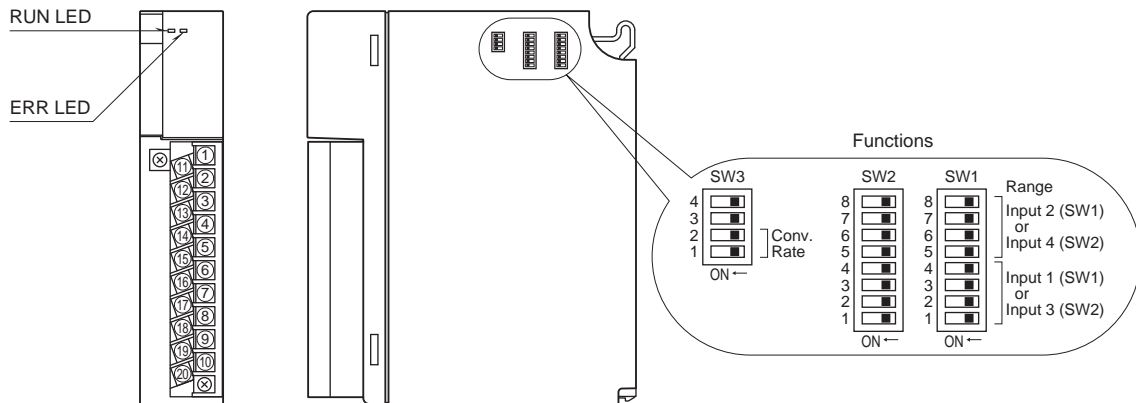

OUTPUT DATA DESCRIPTIONS

Four alarm setpoints are selectable per each input. One (1) word (16 bit) data is transmitted to the PLC or the host device via the R3 network module.

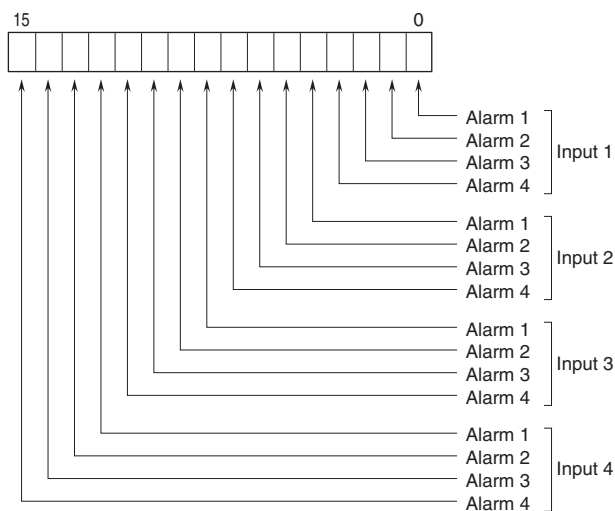

EXTERNAL DIMENSIONS & TERMINAL ASSIGNMENTS unit: mm (inch)

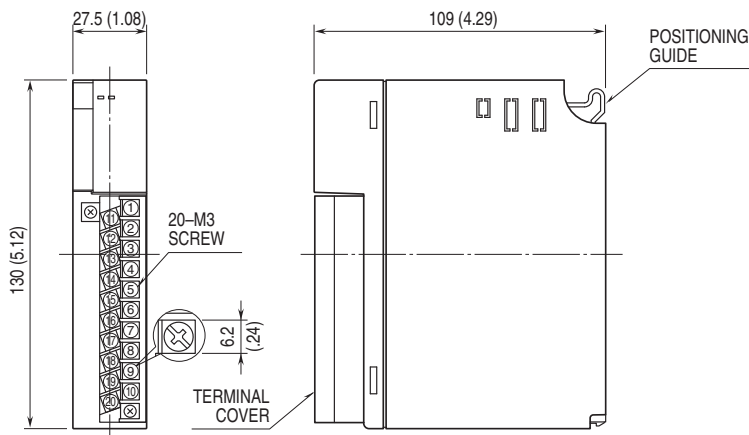

SCHEMATIC CIRCUITRY & CONNECTION DIAGRAM

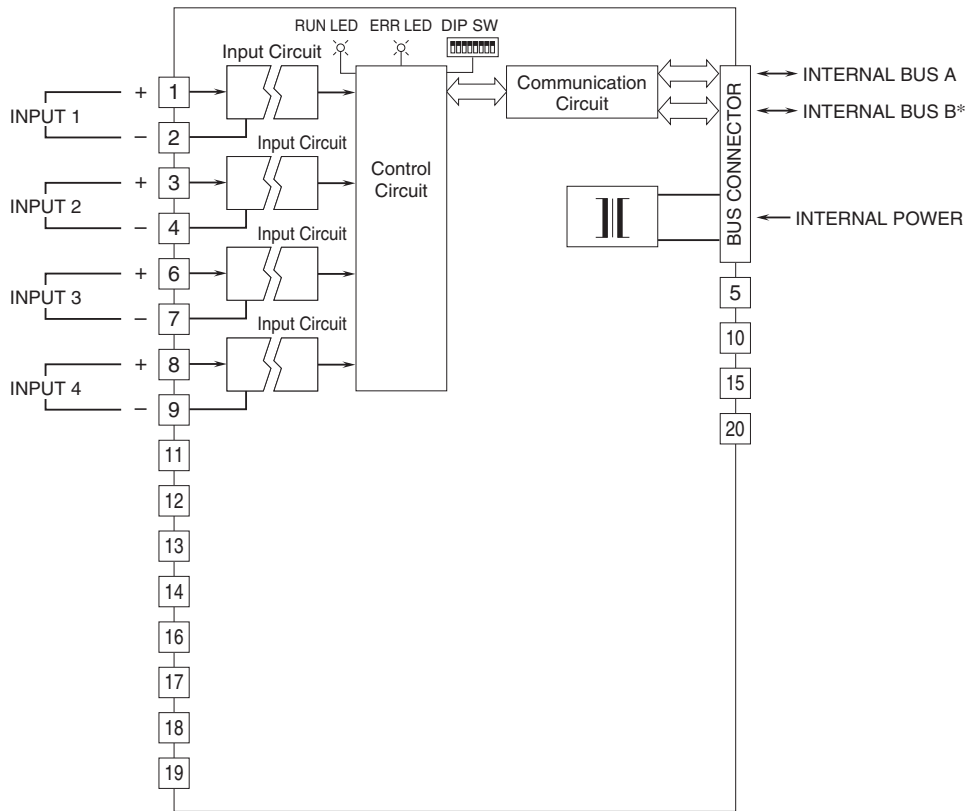

*For dual redundant communication.



Specifications are subject to change without notice.

