

Remote I/O R3 Series

RTD INPUT ALARM MODULE

(4 points, isolated)

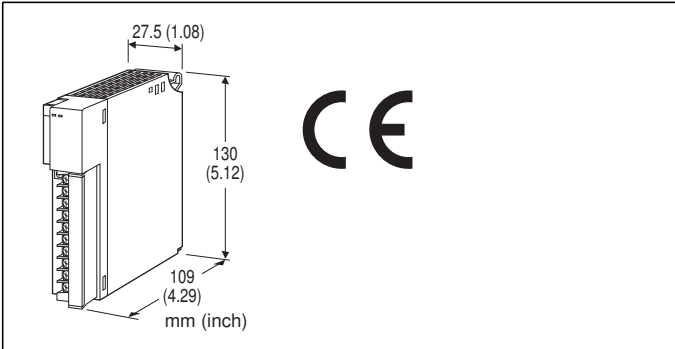

MODEL: R3-AR4[1][2]

ORDERING INFORMATION

- Code number: R3-AR4[1][2]
- Specify a code from below for each [1] and [2]. (e.g. R3-AR4W/CE/Q)
- Specify the specification for option code /Q (e.g. /C01)

NO. OF CHANNELS

4: 4

[1] COMMUNICATION MODE

S: Single

W: Dual

[2] OPTIONS (multiple selections)

Standards & Approvals

blank: Without CE

/CE: CE marking

Other Options

blank: none

/Q: Option other than the above (specify the specification)

SPECIFICATIONS OF OPTION: Q

COATING (For the detail, refer to M-System's web site.)

/C01: Silicone coating

/C02: Polyurethane coating

/C03: Rubber coating

GENERAL SPECIFICATIONS

Connection

Internal bus: Via the Installation Base (model: R3-BSx)

Input: M3 separable screw terminal (torque 0.5 N·m)

Internal power: Via the Installation Base (model: R3-BSx)

Screw terminal: Nickel-plated steel

Isolation: Input 1 to input 2 to input 3 to input 4 to internal bus or internal power

Sensor type: Selectable with the side DIP SW

Temperature unit: °C, °F or absolute temperature selectable with the side DIP SW

Conversion rate: Selectable with the side DIP SW

Burnout detection: Upscale or downscale selectable with the side DIP SW

Linearization: Standard

RUN indicator: Bi-color (red/green) LED;

Red when the bus A operates normally;

Green when the bus B operates normally;

Amber when both buses operate normally.

ERR indicator: Bi-color (red/green) LED;

Red with the burnout; Green in normal operating conditions.

INPUT SPECIFICATIONS

Maximum leadwire resistance: 100 Ω per wire

Sensing current: ≤ 1 mA

Temperature range

RTD	USABLE RANGE	
	°C	°F
Pt 100 (JIS '97/IEC)	-200 to +850	-328 to +1562
Pt 100 (JIS '89)	-200 to +660	-328 to +1220
JPt 100 (JIS '89)	-200 to +510	-328 to +950
Pt 50Ω (JIS '81)	-200 to +649	-328 to +1200
Ni 100	-80 to +250	-112 to +482
Cu 10 (25°C)	-50 to +250	-58 to +482
Pt 1000	-200 to +850	-328 to +1562
Ni 508.4Ω	-50 to +200	-58 to +392
Cu 50	-50 to +150	-58 to +302

INSTALLATION

Operating temperature: -10 to +55°C (14 to 131°F)

Operating humidity: 30 to 90 %RH (non-condensing)

Atmosphere: No corrosive gas or heavy dust

Mounting: Installation Base (model: R3-BSx)

Weight: 200 g (0.44 lb)

PERFORMANCE

Conversion accuracy: ±1.0°C (±1.8°F) except ±3.0°C (±5.4°F) for Cu 10 @ 25°C

Conversion rate: 250 msec. or 1 sec. selectable

Data allocation: 1

Current consumption: 70 mA

Temp. coefficient: ±0.015 %/°C (±0.008 %/°F)

Burnout response time: ≤ 2 sec.

Insulation resistance: ≥ 100 MΩ with 500 V DC



Dielectric strength: 1500 V AC @ 1 minute (input 1 to input 2 to input 3 to input 4 to internal bus or internal power)
2000 V AC @ 1 minute (power input to FG; isolated on the power supply module)

STANDARDS & APPROVALS

CE conformity:

EMC Directive (2004/108/EC)

EMI EN 61000-6-4: 2007/A1: 2011

EMS EN 61000-6-2: 2005

ALARM SETTING

The following parameters are programmable using the PC Configurator Software (model: R3CON).

■ALARM TRIP POINT (-200.0 to +850.0°C or -328 to +1562°F)

Four alarm setpoints are selectable per each input.

■ALARM TYPE (High or Low)

High or Low alarm is selectable for each alarm trip point.

High alarm: An alarm is set when the input signal goes above the setpoint.

Low alarm: An alarm is set when the input signal goes below the setpoint.

■DEADBAND (HYSTERESIS)

(0.0 to 1000.0°C or 0 to 1800°F; factory set to 10.0°C or 100°F)

Deadband (deviation between the points where the alarm is set and reset) is selectable for each alarm trip point.

■ALARM ON DELAY TIME

(0.0 to 99.0 seconds; factory set to 1.0)

The alarm output is set when the preset time elapses after the input has entered in the alarm range.

This setting is common to all four points.

■POWER ON DELAY TIME

(0.0 to 99.0 sec.; factory set to 5.0)

The alarm output start functioning in the preset time after the power has been turned on.

This setting is common to all four points.

■ALARM HOLD TIME

(0.0 to 99.0 seconds; factory set to 1.0)

The alarm output is held for the preset time even if it is reset in shorter time.

This setting is common to all four points.



EXTERNAL VIEW

■ FRONT VIEW

■ SIDE VIEW

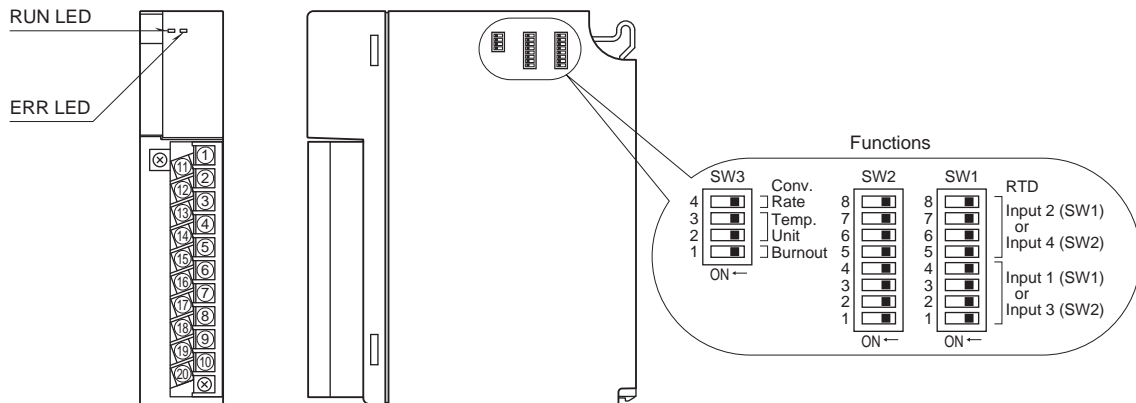

OUTPUT DATA DESCRIPTIONS

Four alarm setpoints are selectable per each input. One (1) word (16 bit) data is transmitted to the PLC or the host device via the R3 network module.

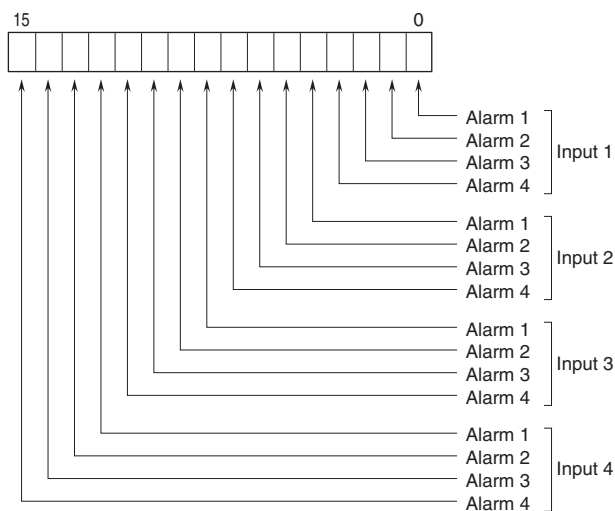

EXTERNAL DIMENSIONS & TERMINAL ASSIGNMENTS unit: mm (inch)

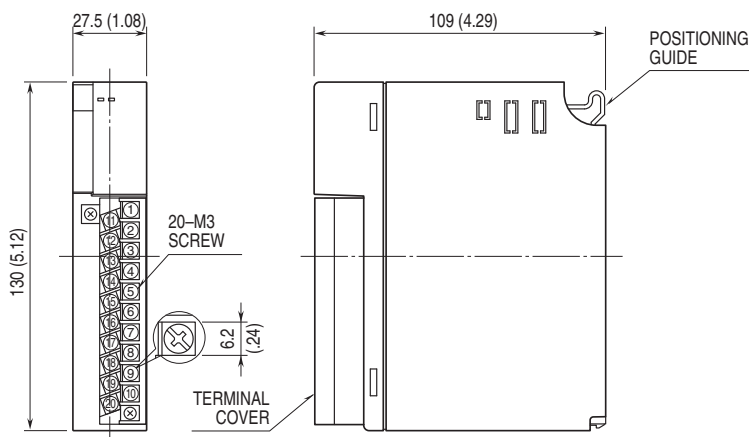

SCHEMATIC CIRCUITRY & CONNECTION DIAGRAM

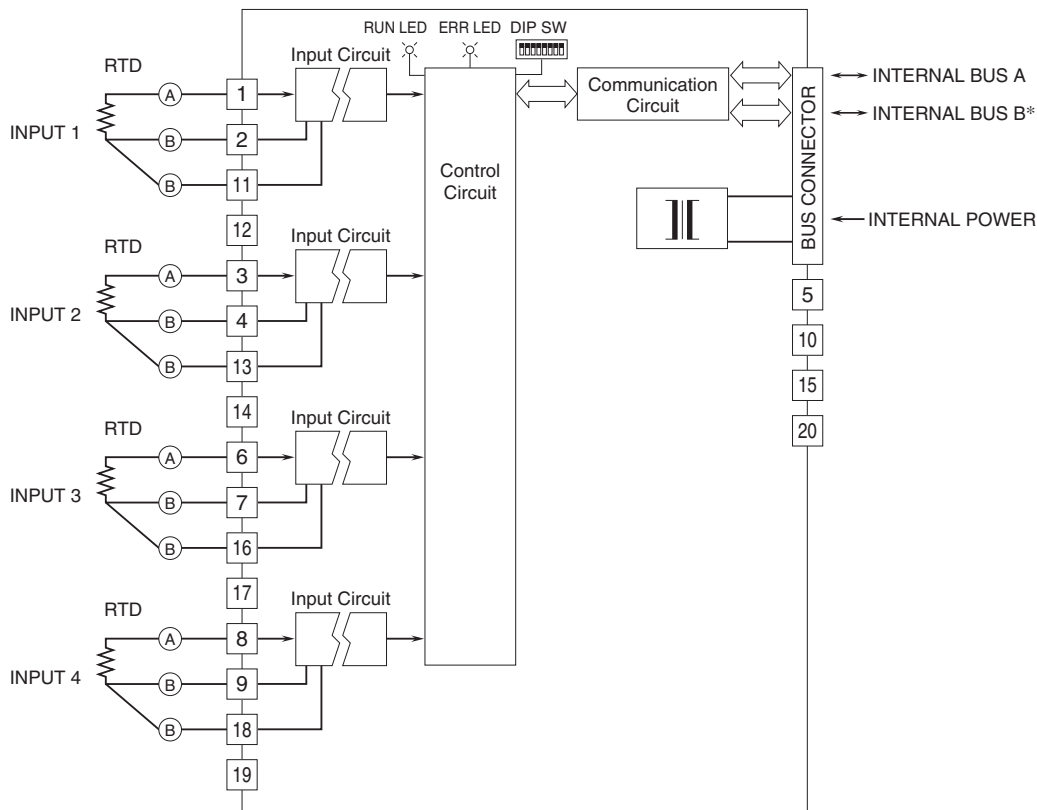

*For dual redundant communication.

• Unused Input Channels

Close across the unused input terminals with a resistor as shown below and set the DIP switch for Pt 100 input.

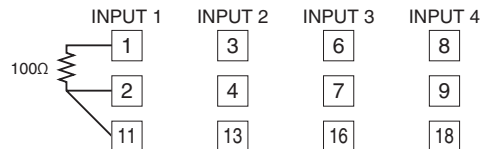

Unused channels left open are equal to the burnout, which turns the red ERR LED on and sets a burnout flag at the PLC or the host device.

Connecting the resistor means approx. 0 °C. An alarm setpoint must be set to a value that does not trip an unwanted alarm.

Unused channels can be specified and set so on the PC Configurator Software (model: R3CON) without needing to connect resistors at the field terminals.



Specifications are subject to change without notice.