

Remote I/O R1M Series

CONTACT I/O MODULE

(4 totalized counter inputs, 8 contact inputs and outputs)

Functions & Features

- Totalized counter inputs
- Counts stored in E²PROM
- Easy system expansion via Modbus RTU

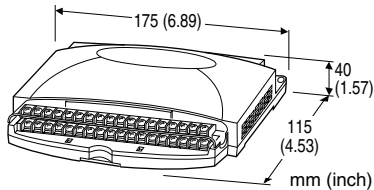

MODEL: R1M-P4T-[1]

ORDERING INFORMATION

- Code number: R1M-P4T-[1]
- Specify a code from below for [1]
(e.g. R1M-P4T-M2)

FIELD TERMINAL TYPE

T: M3 screw terminals

[1] POWER INPUT

AC Power

M2: 100 - 240 V AC (Operational voltage range 85 - 264 V, 47 - 66 Hz)

DC Power

R: 24 V DC
(Operational voltage range 24 V \pm 10 %, ripple 10 %p-p max.)

RELATED PRODUCTS

- R1X configurator software (model: R1CON)
Downloadable at M-System's web site.
A dedicated cable is required to connect the module to the PC. Please refer to the internet software download site or the users manual for the PC configurator for applicable cable types.

GENERAL SPECIFICATIONS

Connection

Power input, transmission: Euro type connector terminal

RS-232-C: 9-pin D-sub connector (male)
(Lock screw No. 4-40 UNC)

I/O: M3 screw terminals

Channel selector for the digital display: Rotary DIP switch;
1 thr. 8: ch.1 thr. ch.8 contact input
A thr. D: ch.A thr. ch.D totalized counter input
0, 9, E, F: no display

Isolation: RS-232-C or RS-485 to I/O to power

Node address setting: Rotary switch; 1 - F (15 nodes)

RUN indicator LED: Green light blinks in normal conditions.

Count memory at power loss: Count value is saved in the the non-volatile memory (E²PROM) when the power supply is lost.

Number of rewritable times: 10⁵ times

Data storing characteristics: 10 years at 20°C

■ Indicators

Digital display: 6-digit red LED; 4.6 mm high; Shows either totalized (lower 6 digits only) or momentary value; selectable with internal DIP switch

COMMUNICATION

Baud rate: 38.4 kbps

Communication: Half-duplex, asynchronous, no procedure

Protocol: Modbus RTU

Refer to Modbus Protocol Reference Guide (EM-5650) for supported functions.

■ RS-232-C

Standard: Conforms to RS-232-C, EIA

Transmission distance: 10 meters max.

■ RS-485

Standard: Conforms to RS-485, EIA

Transmission distance: 500 meters max.

Transmission media: Shielded twisted-pair cable (CPEV-S 0.9 dia.)

INPUT SPECIFICATIONS

■ **Totalized Counter Input (high speed):** Dry contact, 4 points

Commons: All negatives

Max. input frequency: 10 kHz

Minimum pulse width: 50 μ sec.

Max. counter value: 999 999 999 (reset to zero at overflow)

Sensing: Approx. 5 V DC (pull-up resistance 22 k Ω); \leq 0.8 V at Lo; \geq 4 V at Hi

Caution: The totalized counter itself can accept frequencies as high as 10 kHz. In order to eliminate unwanted input by chattering, be careful to choose an input device to be free of the problem (e.g. mercury relay).

■ **Contact Input:** Dry contact, 8 points

Commons: All negatives

Sensing: Approx. 5 V DC (pull-up resistance 22 k Ω); \leq 0.8 V at Lo; \geq 4 V at Hi

Sampling rate: 50 msec.

Totalizing counter function



Number of input channels: 8

Max. input frequency: 100 Hz

Minimum pulse width: 5 msec.

Max. counter value: 999 999 999 (reset to zero at overflow)

■ **Counter Reset Input:** Dry contact, 1 point

Commons: All negatives

Sensing: Approx. 5 V DC (pull-up resistance 22 k Ω); \leq 0.8 V at Lo; \geq 4 V at Hi

Sampling rate: 50 msec.

Logic: Enable at pulse edge sinking

OUTPUT SPECIFICATIONS

■ **Contact Output:** Open collector, 8 points

Commons: All negatives

Rating: 24 V DC @ 50 mA (resistive load)

Saturation voltage: 1.6 V DC

For use with inductive loads, external protection of contact and noise quenching is recommended.

Sampling rate: 50 msec.

INSTALLATION

Power consumption

•AC: Approx. 10 VA

•DC: Approx. 7 W

Operating temperature: -5 to +60°C (23 to 140°F)

Operating humidity: 30 to 90 %RH (non-condensing)

Mounting: Surface or DIN rail

Weight: 400 g (0.88 lbs)

PERFORMANCE

Multi-transmission time: 5 msec.

Insulation resistance: \geq 100 M Ω with 500 V DC

Dielectric strength: 2000 V AC @ 1 minute (RS-232-C or RS-485 to I/O to power to ground)

EXTERNAL VIEW

■ REAR VIEW

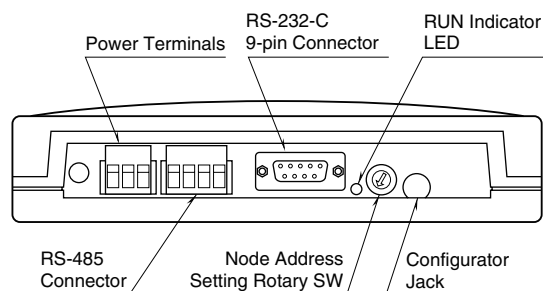

TOP VIEW

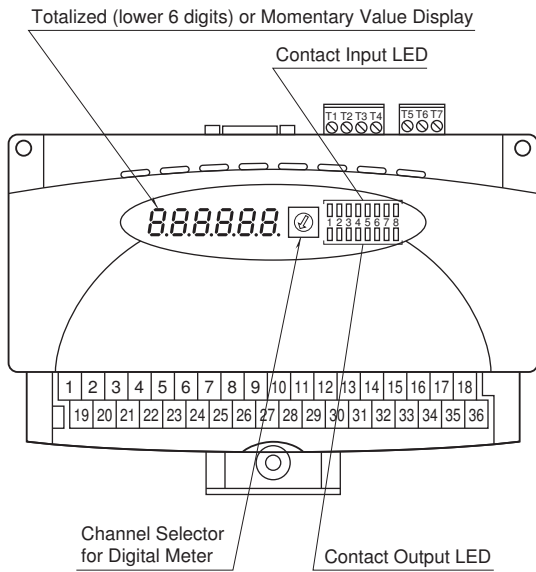

BOTTOM VIEW

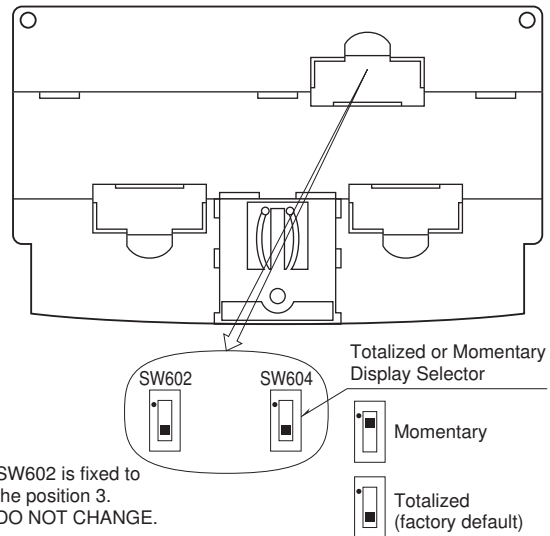

■ RS-232-C INTERFACE



ABBR.	PIN NO.	EXPLANATION OF FUNCTION
BA (SD)	2	Transmitted Data
BB (RD)	3	Received Data
AB (SG)	5	Signal Common
CB (CS)	7	Clear to Send
CA (RS)	8	Request to Send
	1	Not Used.
	4	DO NOT connect. Connecting may cause malfunctions.
	6	
	9	

MODBUS WIRING CONNECTION

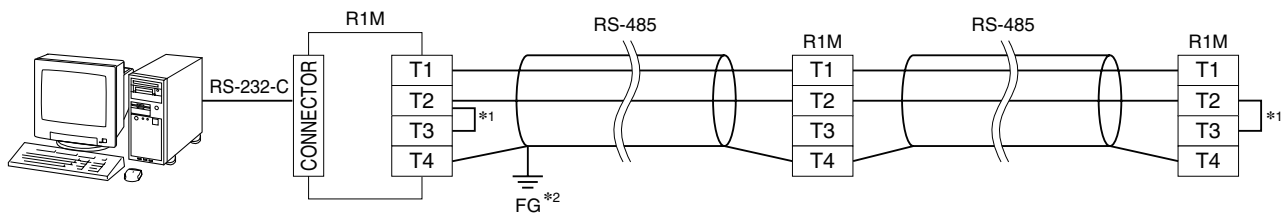

- *1. Internal terminating resistor is used when the device is at the end of a transmission line.
- *2. Install shielded cables to all sections and ground them at single point.



CONNECTION DIAGRAM

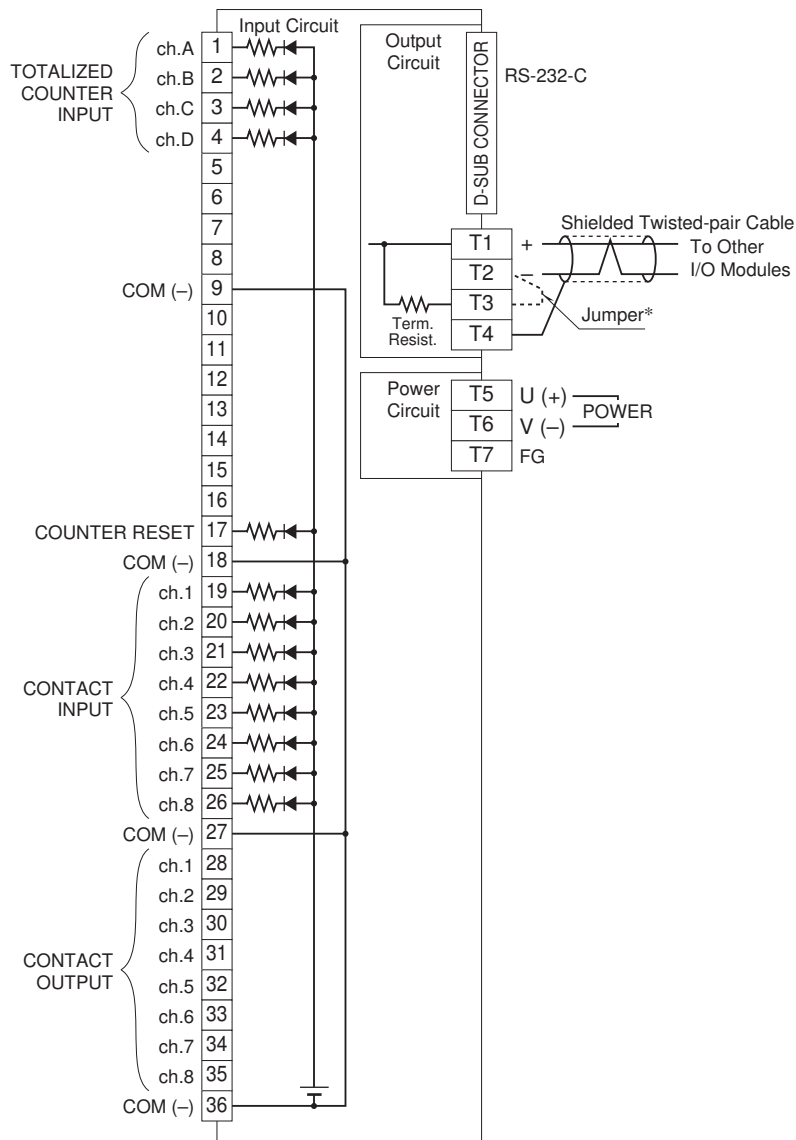

* When the device is located at the end of a transmission line via twisted-pair cable, (when there is no cross-wiring), close across the terminal T2 –T3 with the attached jumper pin (or with a leadwire).

When the device is not at the end, remove the jumper pin.

DO NOT CONNECT to the terminals 5 thr. 8 or 10 thr. 16.
Wrong connection may cause failure of the device.

MODBUS COMMUNICATION

COMMUNICATION PARAMETERS

PARAMETER	SPECIFICATION
Data Mode	RTU
Baud Rate	9600 / 19200 / 38400 (*) bps
Parity	None / Odd (*) / Even
Bit Length	8
Stop Bit	1 (*) / 2
Node Address	1 (*) to 15
Floating Point Data	N/A
Interface	RS-232-C/ RS-485

(*) Ex-factory setting



幸託有限公司
XIN TOP CORPORATION

TEL : (02)2598-1199

E-mail : info@xintop.com

FAX : (02)2596-2331

Website : www.xintop.com

FUNCTION CODES & SUPPORTED CODES

CODE	NAME		
01	Read Coil Status	X	Digital output from the slave
02	Read Input Status	X	Status of digital inputs to the slave
03	Read Holding Registers	X	General purpose register within the slave
04	Read Input Registers	X	Collected data from the field by the slave
05	Force Single Coil	X	Digital output from the slave
06	Preset Single Registers	X	General purpose register within the slave
07	Read Exception Status		
08	Diagnostics		
09	Program 484		
10	Poll 484		
11	Fetch Comm. Event Counter		Fetch a status word and an event counter
12	Fetch Comm. Event Log		A status word, an event counter, a message count and a field of event bytes
13	Program Controller		
14	Poll Controller		
15	Force Multiple Coils	X	Digital output from the slave
16	Preset Multiple Registers	X	General purpose register within the slave
17	Report Slave ID		Slave type / 'RUN' status
18	Program 884/M84		
19	Reset Comm. Link		
20	Read General Reference		
21	Write General Reference		
22	Mask Write 4X Register		
23	Read/Write 4X Register		
24	Read FIFO Queue		

DATA ADDRESS

	ADDRESS	DATA FORMAT	NAME
Coil (0X)	1 – 8	bit	DO
	49	bit	All counters reset
	50	bit	Pulse logic to count
Input Status (1X)	1 – 8	bit	DI
Input Register (3X)	1 – 16	UL	Totalized count (ch.1 – 8)
	17 – 24	UL	Totalized count (ch.A – D)
	33 – 40	UI	Momentary value (ch.1 – 8)
	41 – 44	UI	Momentary value (ch.A – D)
	513	I	System status
	514 – 521	B16	Model No. ("R1M-x")
	522 – 529	B16	Serial No.
	530 – 537	B16	Hardware version No.
	538 – 545	B16	Firmware version No.
Holding Register (4X)	1 – 16	UL	Counter preset value (ch.1 – 8)
	17 – 24	UL	Counter preset value (ch.A – D)

bit = 1 bit, UL = 32-bit integer, I = signed 16-bit integer, UI = 16-bit integer, B16 = 16-byte character

INPUT DATA

- 32-bit Integer, No sign

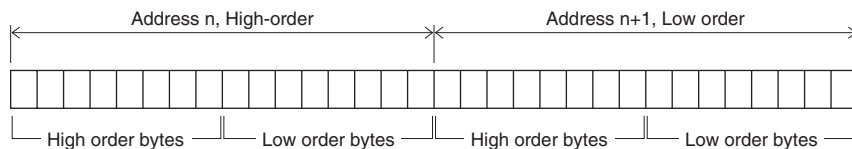

EXTERNAL DIMENSIONS & TERMINAL ASSIGNMENTS unit: mm (inch)

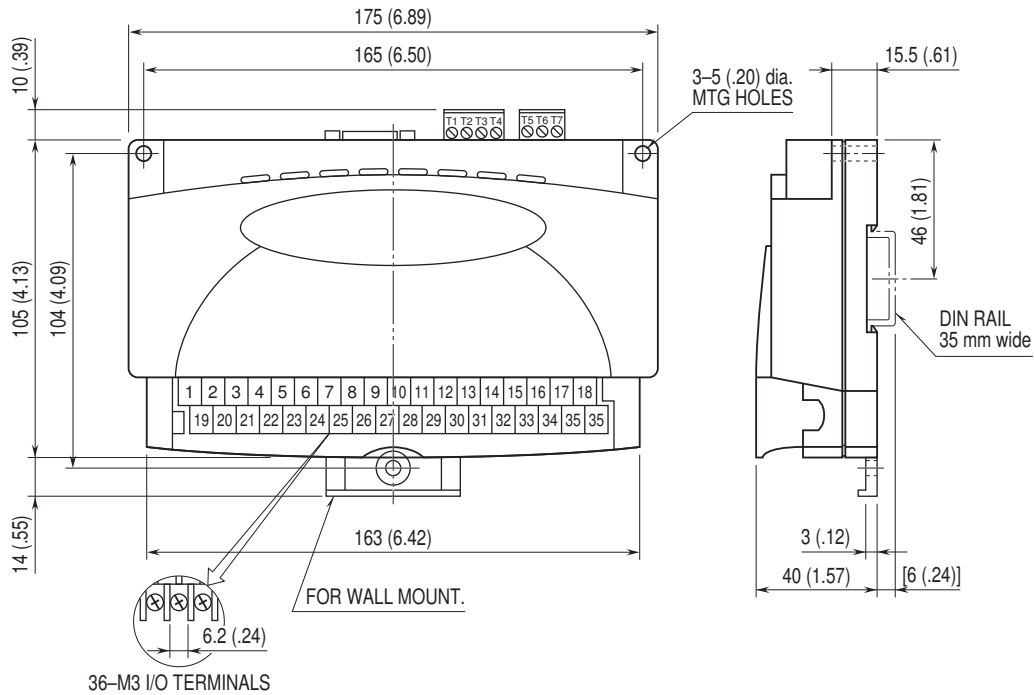

SYSTEM CONFIGURATION EXAMPLES

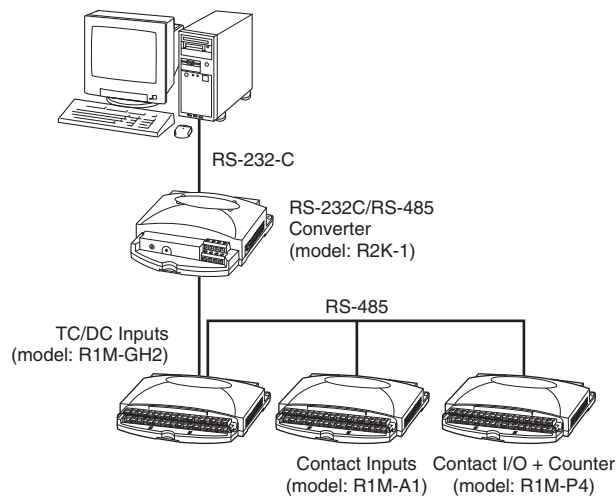

When the cable distance between the PC and the R1Ms is long, insert an RS-232C/RS-485 Converter for isolation.



Specifications are subject to change without notice.