

Lightning Surge Protectors for Electronics Equipment M-RESTER

LIGHTNING SURGE PROTECTOR FOR LonWorks

(life monitor)

Functions & Features

- Designed specifically for the network
- Life monitor function helps you to decide when you should replace the surge protector
- LED and alarm contact output indicate the degradation and life span of the surge protection circuits
- Easy maintenance thanks to discharge elements installed on the element module
- No interruption of signal even unplugging head element
- DIN rail mounting

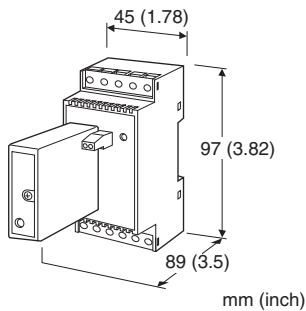

HEAD ELEMENT MODEL: MDW5ALW-E

BASE MODEL: MDW5ALW-B-[1]

ORDERING INFORMATION

Order the both pieces of this surge protector (the head element and the base), respectively required for the use. Order the pieces by separate only for replacement.

- Head element
Code number: MDW5ALW-E
- Base
Code number: MDW5ALW-B-[1]
Specify a code from below for [1].
(e.g. MDW5ALW-B-R)

[1] POWER INPUT

AC Power

M2: 100 - 240 V AC (Operational voltage range 90 - 264 V, 47 - 66 Hz)

DC Power

R: 24 V DC
(Operational voltage range 24 V \pm 10 %, ripple 10 %p-p max.)
P: 110 V DC
(Operational voltage range 85 - 150 V, ripple 10 %p-p max.)

APPLICABLE NETWORK

LonWorks FTT-10A network
This unit is not applicable to LonWorks Link Power network.

GENERAL SPECIFICATIONS

Construction: Plug-in

Degree of protection: IP20 (If the solderless terminals are covered with insulation tubes.)

Surge protection type: Two-port SPD

Connection

- **Transmission, power & grounding:** M3 screw terminals (torque 0.8 N·m)
- **Alarm output:** Euro Type Connector Terminal (torque 0.6 N·m)

Applicable wire size

Line, communication: See the 'External Dimensions.'

Alarm output: 0.2 to 2.5 mm² (7 mm exposed)

Screw terminal

- **Transmission, power & grounding:** Nickel-plated steel
- **Alarm output:** Tin-plated copper alloy

Housing material: Flame-resistant resin (black)

Indicators

- **ALM:** Green/Amber/Red tricolor LED
OFF when no surge is detected.
Green ON when surge is detected more than once.
Amber ON when element life is about to expire.
(Prepare to replace)
Red ON when element life is expired or deteriorated or internal battery is drained. (Replace)
- **PWR:** Green LED
ON when power is supplied.
OFF when the base power circuit is in error.

Degradation judged: When the leakage current at the voltage limiter exceeds approx. 100 μ A

Life time judged: When the number of discharges of the discharge element reaches the expected life span.

Alarm contact: Relay N.C contact

- **Element error:** ON when life span of the discharge element has expired, the voltage limiter is degraded, battery drain or element is removed.
- **Base error:** ON with power circuit error or power supply failure

Rated load: 250 V AC @ 1 A (cos ϕ = 1)

30 V DC @ 1 A (resistive load)

Maximum switching voltage: 264 V AC or 125 V DC



Maximum switching power: 250 VA or 30 W

Minimum load: 5 V DC @ 10 mA

Battery: Lithium battery built in the element, used for life time judgement. No recharge or replacement available.

Battery life: 10 years minimum

STANDARDS & APPROVALS

Surge protection: IEC 61643-21: 2000

(Categories C1, C2)

INSTALLATION

Power consumption

•AC: Approx. 2 VA at 100 V

Approx. 3 VA at 200 V

Approx. 4 VA at 240 V

•DC: ≤ 2 W

Operating temperature: -10 to +55°C (14 to 131°F)

Operating humidity: 30 to 90 %RH (non-condensing)

Mounting: DIN rail

Weight: 160 g (0.35 lbs)

PERFORMANCE

Max. continuous operating voltage (Uc):

Line to line: ± 1.5 V min

Line to earth: ± 100 V min

SHLD to earth: ± 160 V min

Voltage protection level (Up):

@ 4 kV (1.2/50 μ sec.)

Line to line: ± 30 V max.

Line to earth: ± 370 V max.

SHLD to earth: ± 800 V max.

Response time:

Line to line: ≤ 4 nsec.

Line or SHLD to earth: ≤ 20 nsec.

Leakage current

(@ max. continuous operating voltage)

Line to line: ≤ 50 μ A

Line to earth: ≤ 20 μ A

SHLD to earth: ≤ 5 μ A

Max. discharge current (Imax): 10 kA (8/20 μ sec.), 1.0 kA

(10/350 μ A)

Nominal current (In): 100 mA

Insulation resistance: ≥ 100 M Ω with 500 V DC

(surge protector circuit to alarm contact to power)

Dielectric strength: 2000 V AC @ 1 minute

(surge protector circuit to alarm contact to power)

Internal series resistance: ≤ 3.8 Ω (including return)

≤ 4.2 Ω (for only base, including return)

AC durability: 1 Arms (60 Hz 1 sec.) 5 times

Capacitance @ 1 MHz:

Line to line: Approx. 100 pF

Line to earth: Approx. 100 pF

SHLD to earth: Approx. 100 pF



EXTERNAL VIEW

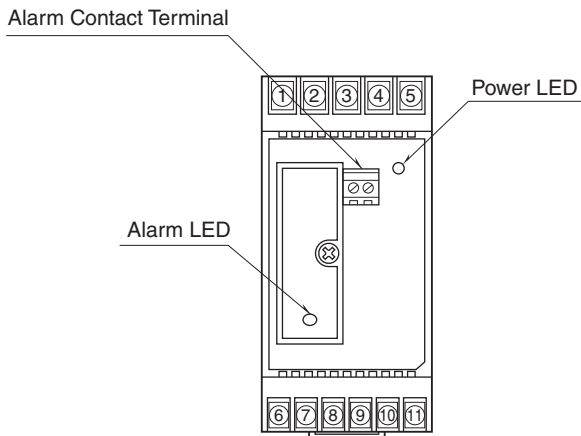

EXTERNAL DIMENSIONS & TERMINAL ASSIGNMENTS unit: mm (inch)

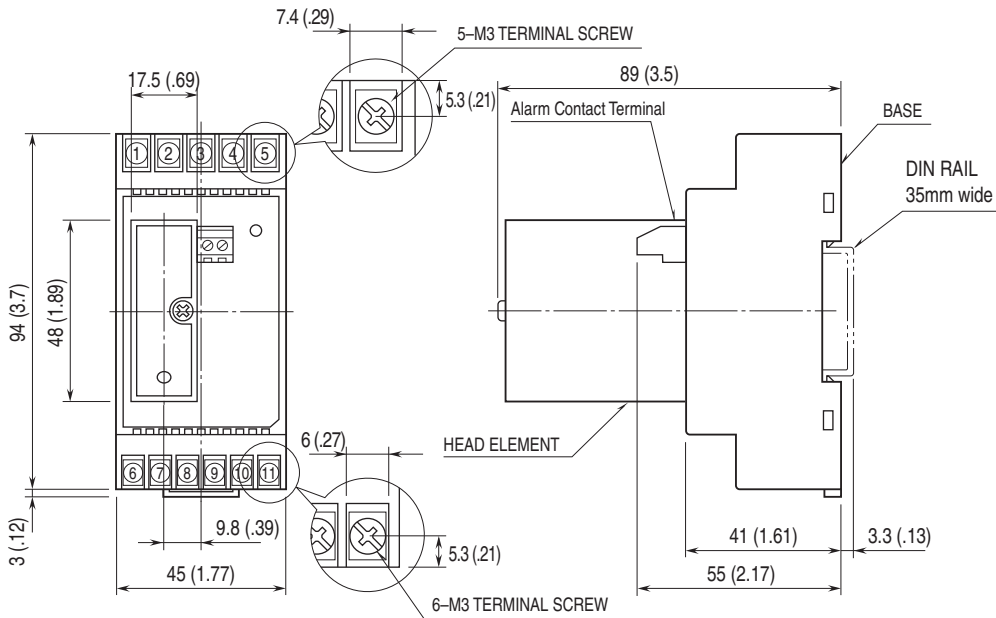

• When mounting, no extra space is needed between units.



SCHEMATIC CIRCUITRY & CONNECTION DIAGRAM

■ CONNECTION DIAGRAM

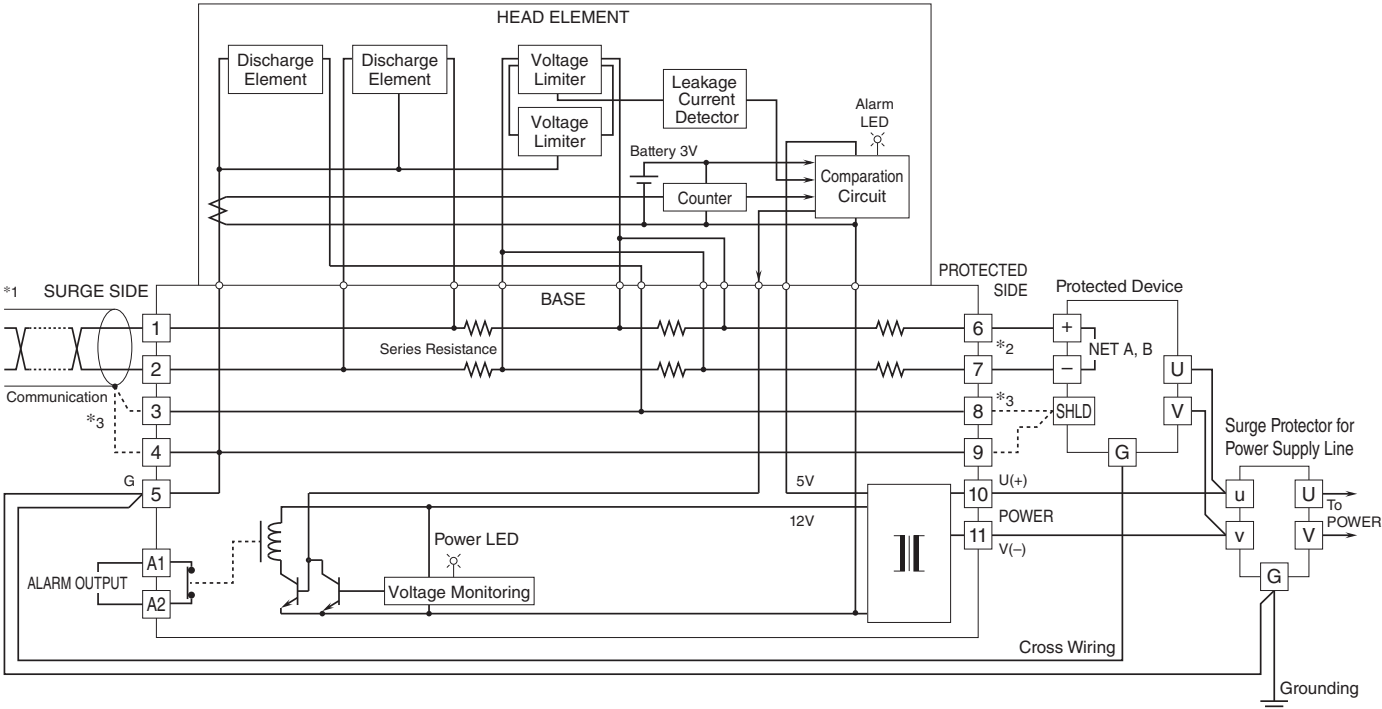

- *1. Be sure to use twisted-pair cables.
- *2. No polarity.
- *3. With shielded twisted-pair cables, connect the shield of the cable to the '3' terminal of the M-Rester for floating, and with the '4' terminal for grounding. Follow instructions provided with the protected device whether '8' and '9' terminals should be connected or not. However, if the shield terminal of the protected device is not isolated from NET A / B, DO NOT connect '8' and '9' terminals to the protected device.



■ NETWORK CONFIGURATION

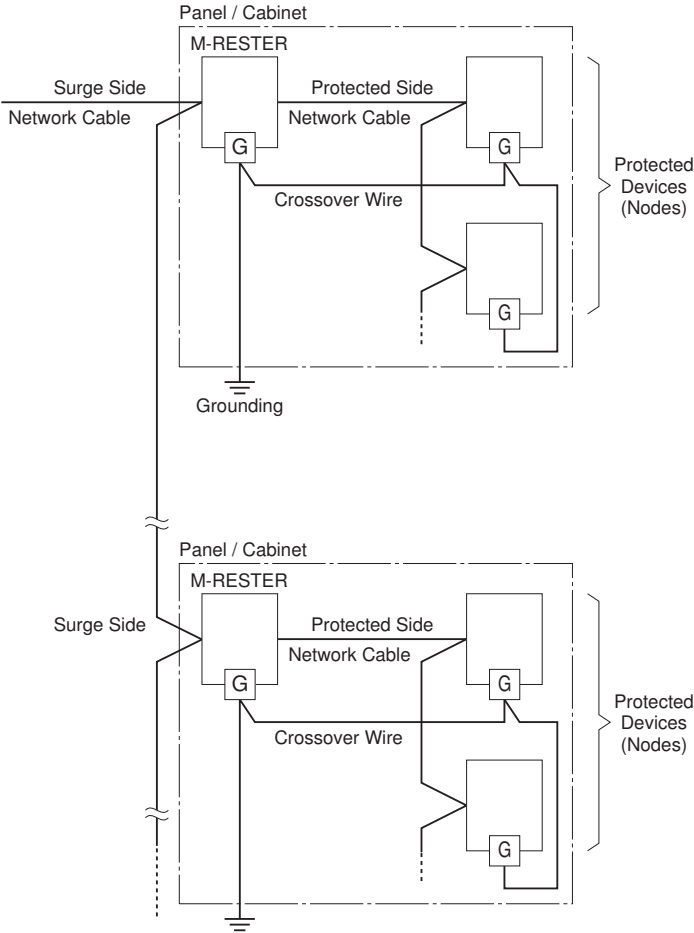

- The M-RESTER is applicable to networks which consist only of FTT-10A. Not applicable to the ones connected to Link Power network.
- The maximum number of nodes connectable to the network segment is reduced by one when one unit of M-RESTER is added.
- When the distance between nodes are relatively long (e.g. grouped and separated by cabinets), install the M-RESTER by each group of devices. Insert the M-RESTER at the surge side of the network.
- For detailed information on the network, refer to LONWORKS FTT-10A Free Topology Transceiver User's Guide provided by Echelon.



Specifications are subject to change without notice.

