

Lightning Surge Protectors for Electronics Equipment M-RESTER

LIGHTNING SURGE PROTECTOR FOR PROFIBUS-PA

(ultra-slim)

Functions & Features

- High discharge current capacity 20 kA (8 / 20 μ s), 1 kA (10 / 350 μ s)
- Ultra-thin 7-mm-wide module can be mounted in high density
- Excellent protection employing multi-stage SPD circuits
- DIN rail mounting and grounding
- Shield terminal provided
- Conforms with FISCO
- CE marking

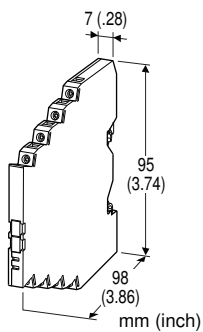

MODEL: MD7PA-[1][2]

ORDERING INFORMATION

- Code number: MD7PA-[1][2]
- Specify a code from below for each [1] and [2]. (e.g. MD7PA-FF0)
- For the safety approval code 2, specify the product's destination country using Ordering Information Sheet (No. ESU-8057).

[1] SHIELD TERMINAL (to earth)

- FF: Floating
- FG: Grounding

[2] SAFETY APPROVAL

- 0: None
- 2: CENELEC intrinsic safety (ATEX)

APPLICABLE NETWORK

PROFIBUS-PA and other networks complied with IEC 61158-2

Caution: Power supply to the bus must be limited to 400 mA or less.

GENERAL SPECIFICATIONS

- Construction:** Slim-sized front terminal structure
- Degree of protection:** IP20
- Connection:** Euro terminal block (torque 0.3 N·m)
- Applicable wire size:** 0.2 - 2.5 mm²
- Grounding:** DIN Rail
- Housing material:** Flame-resistant resin (black)

INSTALLATION

- Operating temperature:** -25 to +85°C (-13 to +185°F)
(See Safety Parameters for use in a hazardous location.)
- Operating humidity:** 30 to 90 %RH (non-condensing)
- Mounting:** DIN Rail (TH35-7.5, 1-mm-thick)
- Oxide film on the surface of an aluminium rail may lower the electric conductivity between this module and the ground. Use a steel or copper rail.
- Weight:** 70 g (2.5 oz)

PERFORMANCE

Values for the floating type (FF). Shortcircuited for the grounding type (FG).

	LINE TO LINE	LINE TO EARTH	SHLD TO EARTH
Max. continuous operating voltage (Uc)	±32V	±160V	±160V*1
Voltage protection level (Up) @4kV (1.2 / 50 μ s)	±60V	±800V	±800V*1
Leakage current @Uc	≤5 μ A	≤5 μ A	≤5 μ A*1
Response time	≤4 nsec.	≤20 nsec.	≤20 nsec.*1
Approx. capacitance @10 kHz	1500 pF	100 pF	100 pF*1
Max. discharge current (Imax)	20kA (8 / 20 μ s) 1.0kA (10 / 350 μ s)		
Nominal current (In)	400mA		
Internal series resistance	1.5 Ω ±10% per line		



幸託有限公司
XIN TOP CORPORATION

TEL : (02)2598-1199
FAX : (02)2596-2331

E-mail : info@xintop.com
Website : www.xintop.com

STANDARDS & APPROVALS

CE conformity:

ATEX Directive (94/9/EC)
 Ex ia EN 60079-11: 2007
 Category 1G EN 60079-26: 2007
 EMC Directive (2004/108/EC)
 EMI EN 61000-6-4: 2007
 EMS EN 61000-6-2: 2005

Safety approval:

CENELEC: Intrinsic safety (ATEX)
 Ⓢ II 1G, Ex ia IIC; T4 and T5
 EN 60079-0: 2006
 EN 60079-11: 2007
 EN 60079-26: 2007
 EN 60079-27: 2008

Surge protection: IEC 61643-21: 2000
 (Categories C1, C2, D1)

SAFETY PARAMETERS

■ CENELEC / ATEX IS DATA

	Linear Barrier			FISCO Supply
Ui (Vmax)	32V			17.5V
Ii (Imax)	any			400mA
Ci	5 nF			5 nF
Li	0 μH			0 μH
Pi	Temp. Class	Range	Parameter	5.4W
		T4	-25 to +40°C	
		-25 to +60°C	1.2W	
		-25 to +80°C	1.0W	
	T5	-25 to +40°C	1.0W	

EXTERNAL DIMENSIONS & TERMINAL ASSIGNMENTS unit: mm (inch)

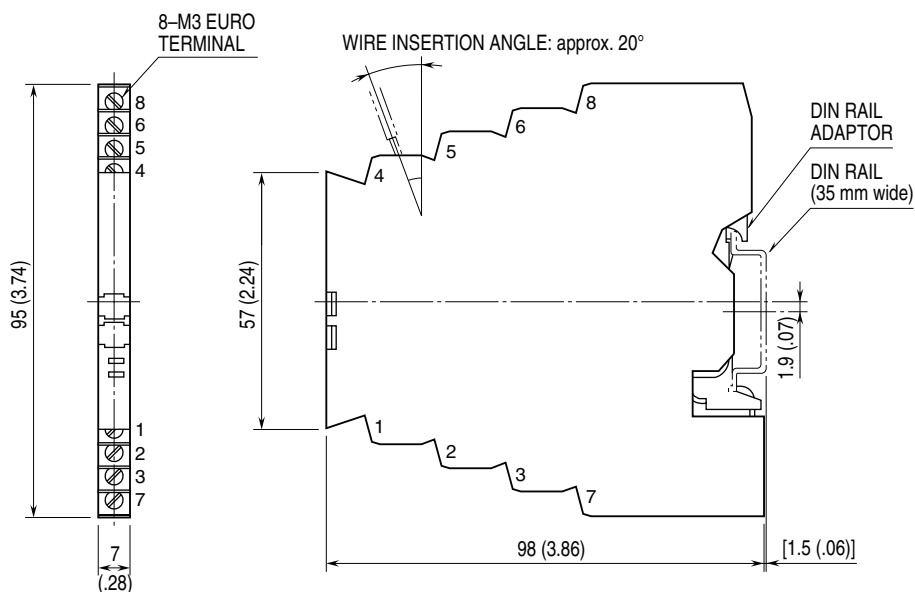

SCHEMATIC CIRCUITRY & CONNECTION DIAGRAM

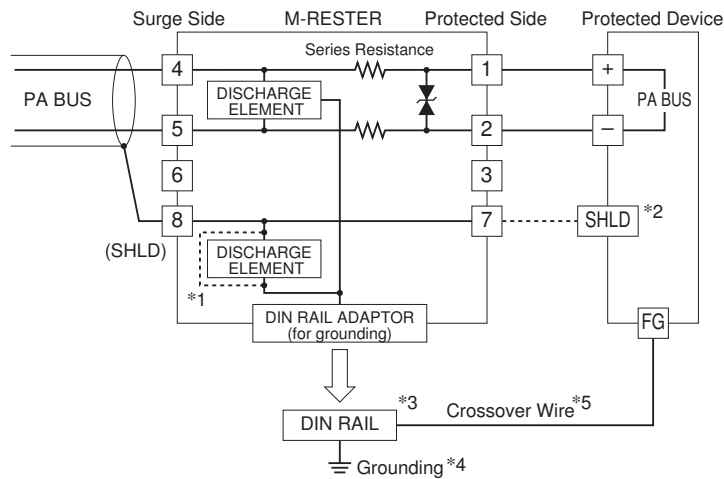

- *1. Choose the grounding (FG) when the shield wire is to be grounded.
- *2. When SHLD is not isolated from PA BUS, DO NOT connect the surge protector's terminal 7 to SHLD.
- *3. Oxide film on the surface of an aluminium rail may lower the electric conductivity between this module and the ground. Use a steel or copper rail.
- *4. Be sure to ground the DIN rail. Recommended grounding resistance max. 100 ohms.
- *5. Cross-wire from the DIN rail to the metal housing of the protected device to equalize the ground potential. Ground only the surge protector when the protected device has no grounding terminal.

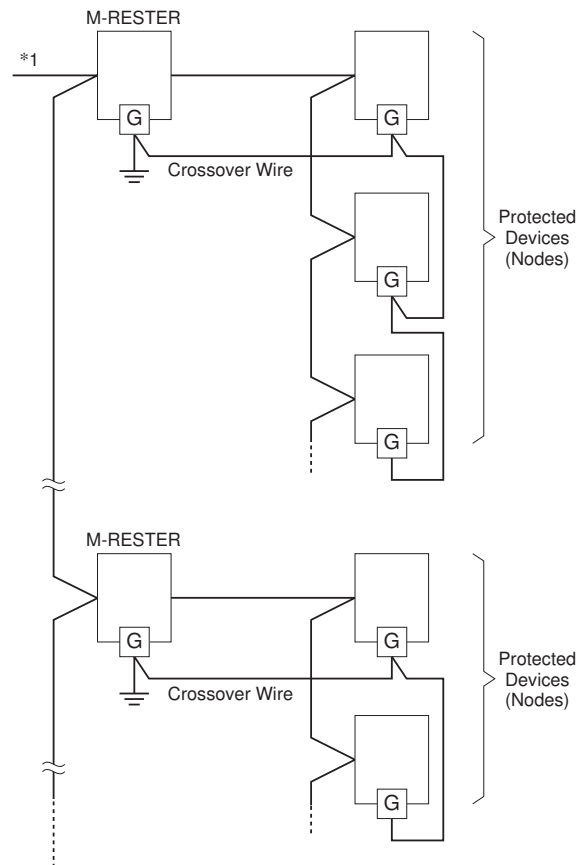

- *1. Fieldbus devices complying with IEC 61158-2 operate by a supply voltage between 9V and 32V DC. Take the MD7PA's internal series resistance into consideration when determining the cable distance if there is a large current flow on the bus line.

When the distance between nodes are relatively long (e.g. grouped and separated by cabinets), install the MD7PA by each group of devices. Insert the MD7PA at the surge side of the network. For detailed information on the network, refer to that provided by PROFIBUS International.





Specifications are subject to change without notice.

