

Lightning Surge Protectors for Electronics Equipment M-RESTER

LIGHTNING SURGE PROTECTOR FOR LonWorks

(ultra-slim, FTT-10A)

Functions & Features

- High discharge current capacity 20 kA (8 / 20 μ s), 1 kA (10 / 350 μ s)
- Ultra-thin 7-mm-wide module can be mounted in high density
- Excellent protection employing multi-stage SPD circuits
- DIN rail mounting and grounding
- Shield terminal provided
- CE marking

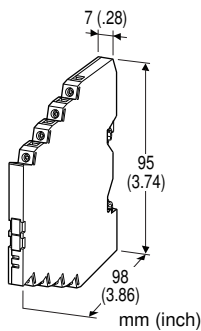

MODEL: MD7LWA-[1][2]

ORDERING INFORMATION

- Code number: MD7LWA-[1][2]
Specify a code from below for each [1] and [2].
(e.g. MD7LWA-FF)
- For the safety approval code /E2, specify the product's destination country using Ordering Information Sheet (No. ESU-8060).

[1] SHIELD TERMINAL (to earth)

- FF: Floating
- FG: Grounding

[2] OPTIONS

Safety approval

- blank: Without
- /E2: CENELEC intrinsic safety (ATEX)

APPLICABLE NETWORK

LonWorks FTT-10A network
This unit is not applicable to LonWorks Link Power network.

GENERAL SPECIFICATIONS

- Construction:** Slim-sized front terminal structure
- Degree of protection:** IP20
- Connection:** Euro terminal block (torque 0.3 N·m)
- Applicable wire size:** 0.2 - 2.5 mm²
- Grounding:** DIN Rail
- Housing material:** Flame-resistant resin (black)

INSTALLATION

- Operating temperature:** -25 to +85°C (-13 to +185°F)
(See Safety Parameters for use in a hazardous location.)
- Operating humidity:** 30 to 90 %RH (non-condensing)
- Mounting:** DIN Rail (TH35-7.5, 1-mm-thick)
Oxide film on the surface of an aluminium rail may lower the electric conductivity between this module and the ground. Use a steel or copper rail.
- Weight:** 70 g (2.5 oz)

PERFORMANCE

Values for the floating type (FF). Shortcircuited for the grounding type (FG).

	LINE TO LINE	LINE TO EARTH	SHLD TO EARTH
Max. continuous operating voltage (Uc)	±1.5V	±100V	±160V*1
Voltage protection level (Up) @4kV (1.2 / 50 μ s)	±30V	±370V	±800V*1
Leakage current @Uc	≤5 μ A	≤20 μ A	≤5 μ A*1
Response time	≤4 nsec.	≤20 nsec.	≤20 nsec.*1
Approx. capacitance @10 kHz	100 pF	100 pF	5 pF*1
Max. discharge current (Imax)	20kA (8 / 20 μ s) 1.0kA (10 / 350 μ s)		
Nominal current (IN)	100mA		
Internal series resistance	≤3.3 Ω including return		
Insertion loss	-0.5 dB max. @DC...5 MHz, Z ₀ = 100 Ω		

STANDARDS & APPROVALS

- CE conformity:**
- ATEX Directive (94/9/EC)
- Ex ia EN 60079-11: 2007
- Category 1G EN 60079-26: 2007
- EMC Directive (2004/108/EC)
- EMI EN 61000-6-4: 2007
- EMS EN 61000-6-2: 2005
- Safety approval:**
- CENELEC: Intrinsic safety (ATEX)
- ⊕ II 1G, Ex ia IIC; T4 and T5
- EN 60079-0: 2006
- EN 60079-11: 2007
- EN 60079-26: 2007

Surge protection: IEC 61643-21: 2000



幸託有限公司
XIN TOP CORPORATION

TEL : (02)2598-1199
FAX : (02)2596-2331

E-mail : info@xintop.com
Website : www.xintop.com

(Categories C1, C2, D1)

SAFETY PARAMETERS

■ CENELEC / ATEX IS DATA

U _i (V _{max})	7V		
I _i (I _{max})	any		
C _i	50 nF		
L _i	0 μH		
P _i	Temp. Class	Range	Parameter
	T4	-25 to +40°C	1.3W
		-25 to +60°C	1.2W
		-25 to +80°C	1.0W
T5	-25 to +40°C	1.0W	

EXTERNAL DIMENSIONS & TERMINAL ASSIGNMENTS unit: mm (inch)

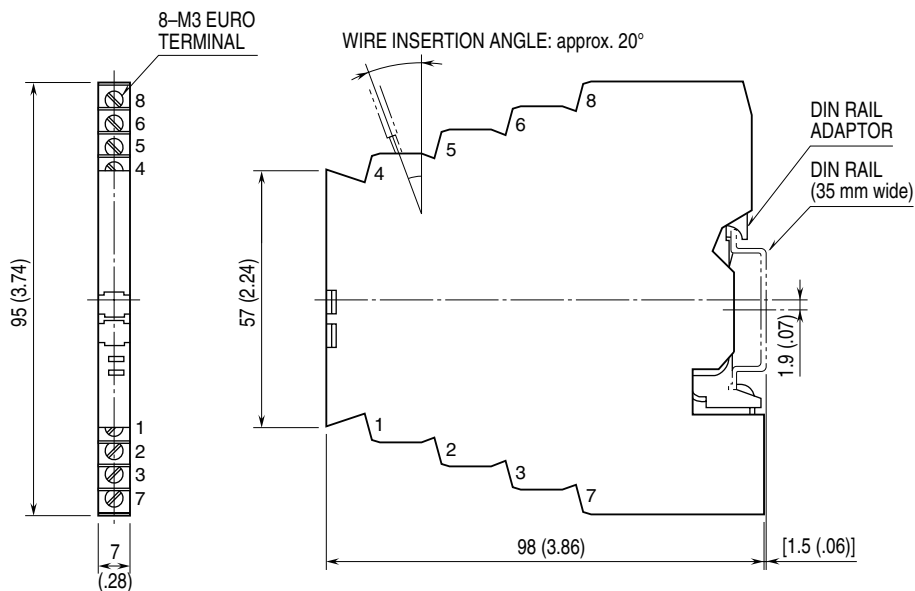

SCHEMATIC CIRCUITRY & CONNECTION DIAGRAM

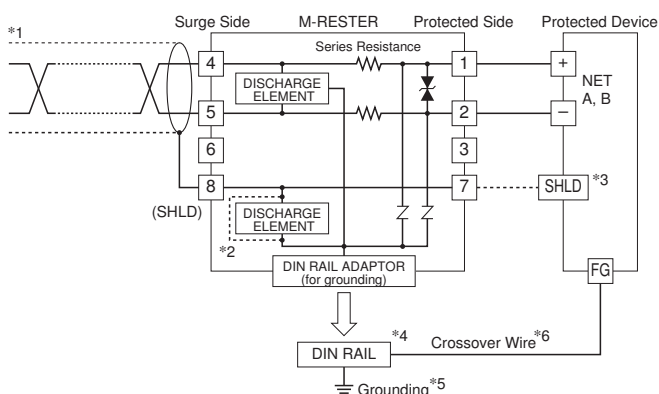

*1. Be sure to use twisted-pair cables.

*2. Choose the M-RESTER – FG when the shield wire is to be grounded.

*3. When the twisted-pair cable is with a shield, connect it to the surge protector's terminal 8, and follow instructions given by the protected device for the terminal 7. When SHLD is not isolated from NET A / B, DO NOT connect the terminal 7 to SHLD.

*4. Oxide film on the surface of an aluminium rail may lower the electric conductivity between this module and the ground. Use a steel or copper rail.

*5. Be sure to ground the DIN rail. Recommended grounding resistance max. 100 ohms.

*6. Cross-wire from the DIN rail to the metal housing of the protected device to equalize the ground potential.
Ground only the surge protector when the protected device has no grounding terminal.



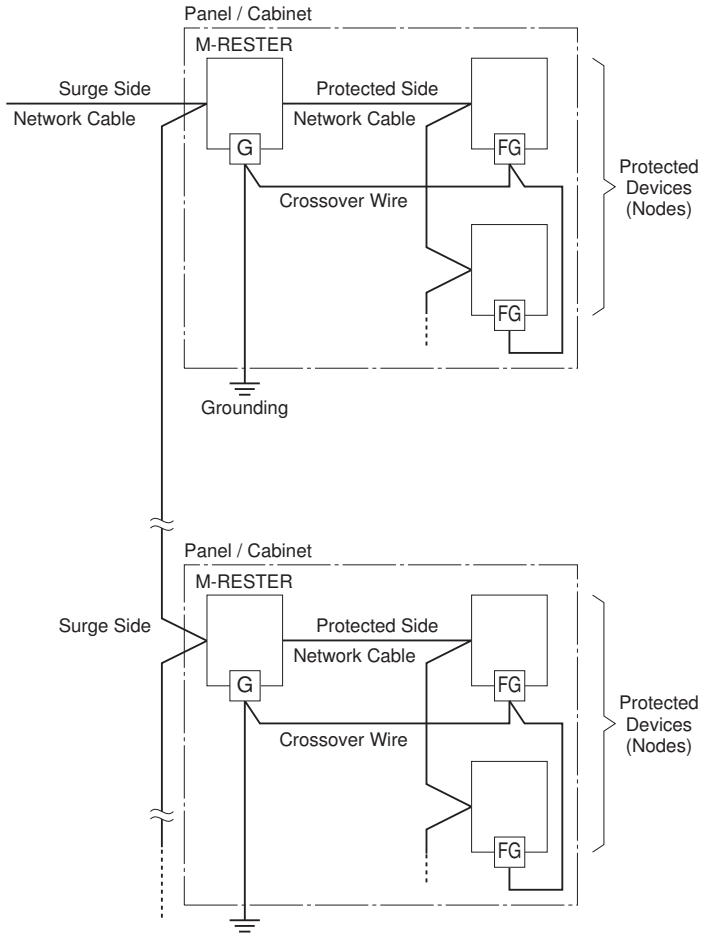

- The M-RESTER is applicable to networks which consist only of FTT-10A.
Not applicable to the ones connected to Link Power network.
- The maximum number of nodes connectable to the network segment is reduced by one when one unit of M-RESTER is added.
- When the distance between nodes are relatively long (e.g. grouped and separated by cabinets), install the M-RESTER by each group of devices. Insert the M-RESTER at the surge side of the network.
- For detailed information on the network, refer to LONWORKS FTT-10A Free Topology Transceiver User's Guide provided by Echelon.



Specifications are subject to change without notice.

