

**Lightning Surge Protectors for
Electronics Equipment M-RESTER**

**LIGHTNING SURGE PROTECTOR FOR
THREE-WIRE SIGNAL LOOP**

(ultra-slim)

Functions & Features

- High discharge current capacity 20 kA (8 / 20 μ s), 1 kA (10 / 350 μ s)
- Ultra-thin 7-mm-wide module can be mounted in high density
- Excellent protection employing multi-stage SPD circuits
- DIN rail mounting and grounding
- CE marking

Typical Applications

- Protecting a 3-wire transmitter loop
- Protecting an electronic device I/O

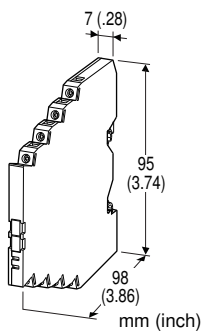

MODEL: MD73W-32[1]

ORDERING INFORMATION

- Code number: MD73W-32[1]
Specify a code from below for [1].
(e.g. MD73W-320)
- For the safety approval code 2, specify the product's destination country using Ordering Information Sheet (No. ESU-8057).

NOMINAL VOLTAGE

32: 32 V DC

[1] SAFETY APPROVAL

- 0: None
- 2: CENELEC intrinsic safety (ATEX)

GENERAL SPECIFICATIONS

- Construction:** Slim-sized front terminal structure
- Degree of protection:** IP20
- Connection:** Euro terminal block (torque 0.3 N·m)
- Applicable wire size:** 0.2 - 2.5 mm²
- Grounding:** DIN Rail
- Housing material:** Flame-resistant resin (black)

INSTALLATION

- Operating temperature:** -25 to +85°C (-13 to +185°F)
(See Safety Parameters for use in a hazardous location.)
- Operating humidity:** 30 to 90 %RH (non-condensing)
- Mounting:** DIN Rail (TH35-7.5, 1-mm-thick)
Oxide film on the surface of an aluminium rail may lower the electric conductivity between this module and the ground. Use a steel or copper rail.
- Weight:** 70 g (2.5 oz)

PERFORMANCE

- Max. continuous operating voltage (Uc):**
Line to line: ± 32 V
Line to earth: ± 32 V
- Voltage protection level (Up) @ 6 kV (1.2 / 50 μ s):**
Line to line: ± 60 V
Line to earth: ± 60 V
- Response time:**
Line to line: ≤ 4 nsec.
Line to earth: ≤ 20 nsec.
- Leakage current @Uc:**
Line to line: ≤ 5 μ A
Line to earth: ≤ 5 μ A
- Max. discharge current (Imax):** 20 kA (8 / 20 μ s); 1.0 kA (10 / 350 μ s)
- Nominal current (In):** 400 mA
- Internal series resistance:** $\leq 2.2 \Omega \pm 20$ % per line

STANDARDS & APPROVALS

- CE conformity:**
ATEX Directive (94/9/EC)
Ex ia EN 60079-11: 2007
Category 1G EN 60079-26: 2007
- EMC Directive (2004/108/EC)
EMI EN 61000-6-4: 2007
EMS EN 61000-6-2: 2005
- Safety approval:**
CENELEC: Intrinsic safety (ATEX)
Ⓜ II 1G, Ex ia IIC; T4 and T5
EN 60079-0: 2006
EN 60079-11: 2007
EN 60079-26: 2007
- Surge protection:** IEC 61643-21: 2000



(Categories C1, C2, D1)

SAFETY PARAMETERS

■ CENELEC / ATEX IS DATA

U _i (V _{max})	32V		
I _i (I _{max})	150mA		
C _i	10 nF		
L _i	150 μH		
P _i	Temp. Class	Range	Parameter
	T4	-25 to +40°C	1.3W
		-25 to +60°C	1.2W
		-25 to +80°C	1.0W
	T5	-25 to +40°C	1.0W

EXTERNAL DIMENSIONS & TERMINAL ASSIGNMENTS unit: mm (inch)

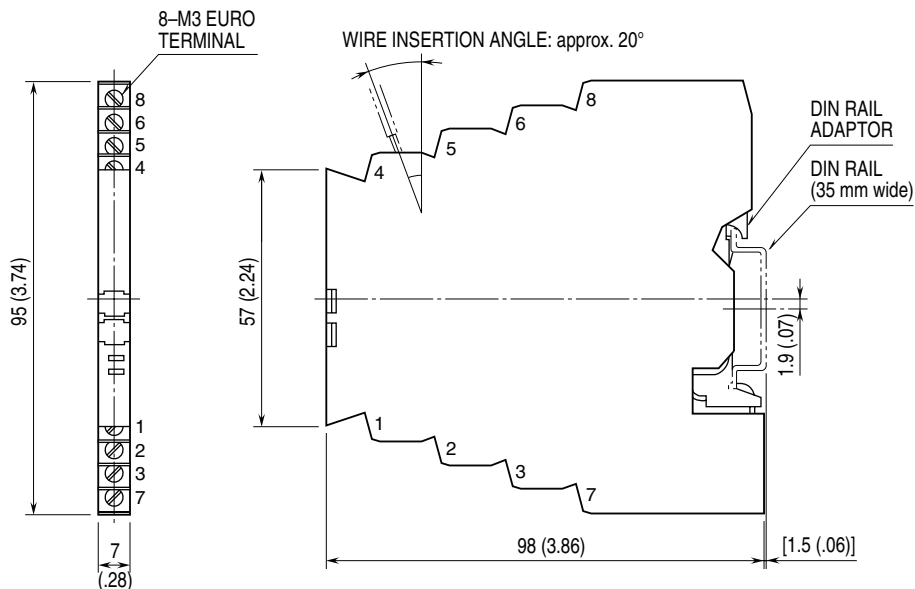

SCHEMATIC CIRCUITRY & CONNECTION DIAGRAM

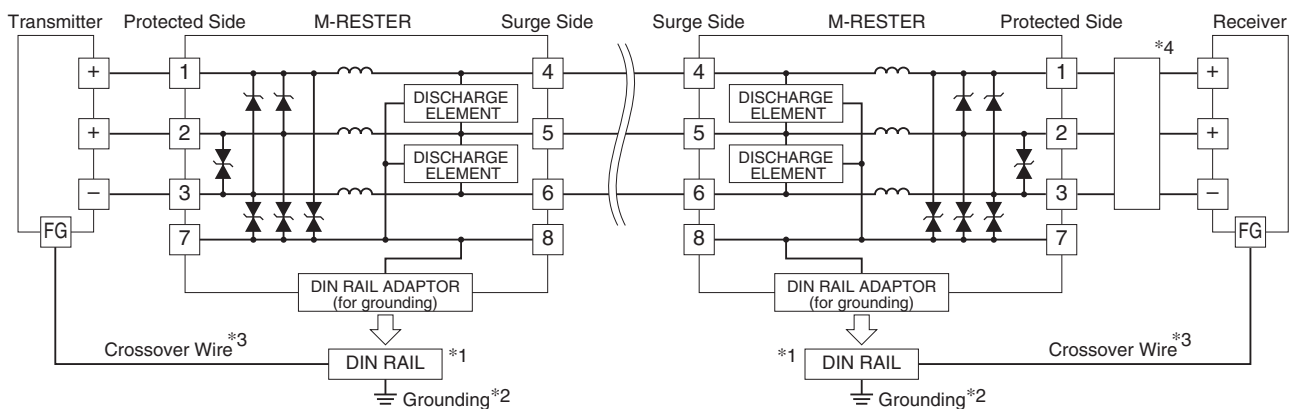

*1. Oxide film on the surface of an aluminium rail may lower the electric conductivity between this module and the ground. Use a steel or copper rail.

*2. Be sure to ground the DIN rail. Recommended grounding resistance $\leq 100\Omega$

*3. Cross-wire between the DIN rail and the metal housing of the protected device to equalize the earth potential.

Ground only the surge protector when the protected device has no ground terminal.

*4. Install a circuit protector if the excitation supply rating is greater than the maximum load current of the surge protector.





Specifications are subject to change without notice.

