

Lightning Surge Protectors for Electronics Equipment M-RESTER

SURGE PROTECTOR FOR PHOTOVOLTAIC SYSTEM (750V DC, 1000V DC USE)

Functions & Features

- Surge protection for photovoltaic array and power conditioner.
- High discharge current capacity 20 kA
- Degraded head element is automatically separated from the power lines by the incorporated thermal breaker, and the LED lamp (turns off) and the relay contact alerts the failure status.
- Breakdown of the surge protector remotely detected with the alarm output
- Photovoltaic system's resistance to earth is measurable without removing the SPD due to spark gap employed between line and earth.

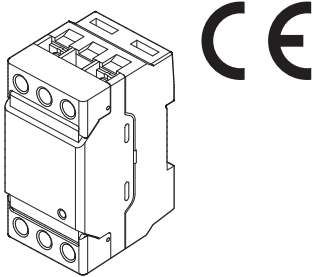

MODEL: MATPH-[1]M[2]

ORDERING INFORMATION

- Code number: MATPH-[1]M[2]
Specify a code from below for each [1] and [2].
(e.g. MATPH-1000MA)

[1] OPERATIONAL VOLTAGE

750: 750 V DC
1000: 1000 V DC

MAXIMUM DISCHARGE CURRENT

M: 20kA (8/20 μ sec.)

[2] ALARM OUTPUT

A: With
Y: Without

GENERAL SPECIFICATIONS

Construction: Standalone; terminal access at the front
Degree of protection: IP20 (If the solderless terminals are covered with insulation tubes.)

Surge protection type: One-port combination type SPD
Connection

Line: M5 screw terminal (torque: 2.5 N·m)

Alarm output: Tension clamp

Applicable wire size

Line: See the drawing below.

Alarm output: 0.13 to 1.5 mm² (8 mm exposed)

Screw terminal

Line: Nickel-plated steel

Alarm output: Tin-plated copper alloy

Housing material: Flame-resistant resin (black)

Alarm output: Trips when the thermal breaker operates.
(N.C. contact)

Rated load:

250 V AC @50 mA (resistive load)

24 V DC @50 mA (resistive load)

Safety function: Thermal breaker incorporated

Monitor LED: Green LED turns on during normal conditions (100 V DC to operational voltage), and turns off during failure condition, power off and the thermal breaker operating.

• Applicable Solderless Terminal Size

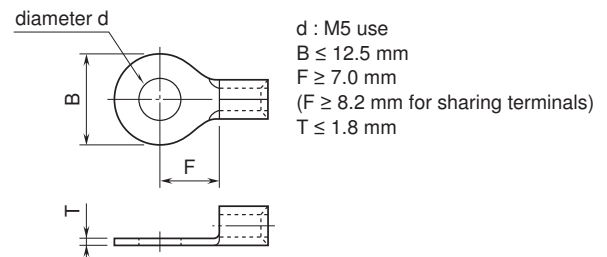

INSTALLATION

Operating temperature: -25 to +80°C (-13 to +176°F)

Operating humidity: 30 to 90 %RH (non-condensing)

Mounting: DIN Rail

Weight: 200 g (0.44 lb)

PERFORMANCE

Max. continuous operating voltage (Uc, Line to line):

750 V DC for MATPH-750

1000 V DC for MATPH-1000

Discharge voltage (Line to earth): 500 V DC

Voltage protection level (Up):

- MATPH-750

Line to line: 2.5 kV (@In)

Line to earth: 1.8 kV (@In)

- MATPH-1000



Line to line: 3.3 kV (@In)

Line to earth: 2.1 kV (@In)

Maximum discharge current (Imax): 20 kA (8/ 20 μ s)

Nominal discharge current (In): 10 kA (8/ 20 μ s)

Response time:

Line to line: ≤ 4 nsec.

Line to earth: ≤ 20 nsec.

Leakage current: ≤ 1 mA

Insulation resistance: ≥ 100 M Ω with 500 V DC (line to alarm output)

Dielectric strength: 2000 V AC @ 1 minute (line to alarm output)

STANDARDS & APPROVALS

Refer to the manuals to comply with the standards.

CE conformity:

Low Voltage Directive (2006/95/EC)

EN 61643-11: 2002

Surge protection:

IEC 61643-1: 1998 Class II

EN 61643-11: 2002 Class II

CONNECTION EXAMPLES

CONNECTION DIAGRAM

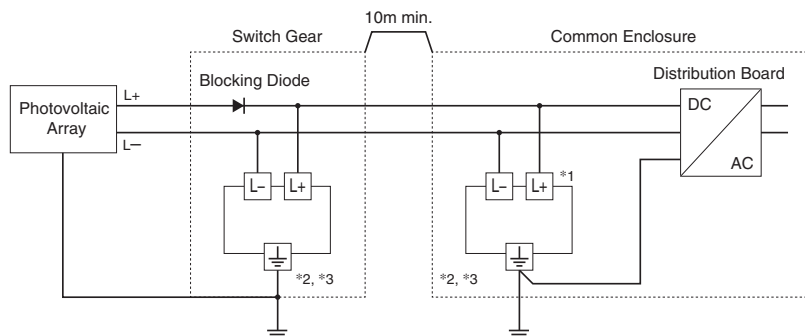

*1. When the wiring distance is longer than 10 m between the power conditioner and the surge protector in the switch gear, install near the power conditioner.

*2. Cable length between the branch point and the earthing: 0.5 m or less recommended

*3. When the solar panel manufacturer requires earthing at negative line of DC side, do NOT use the earth terminal of the MATPH but use the L- terminal. If also, earthing at positive line is necessary, earth the L+ terminal.

CIRCUIT BREAKER POSITION

If you want to use circuit breaker as SPD maintenance switch, insert a wiring MCCB for DC on SPD power side (diagram below).

Even when the output current of solar cell array is low, use 20 AT or more for wiring MCCB.

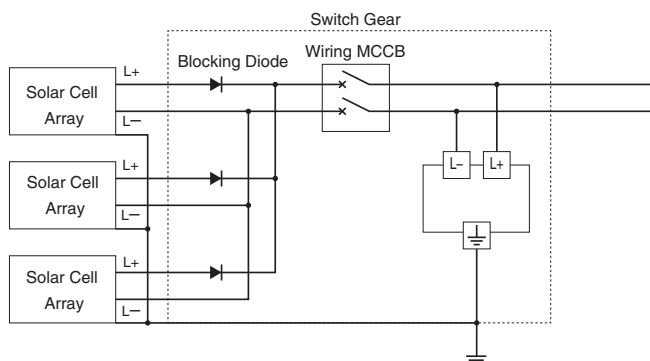

EXTERNAL DIMENSIONS & TERMINAL ASSIGNMENTS unit: mm (inch)

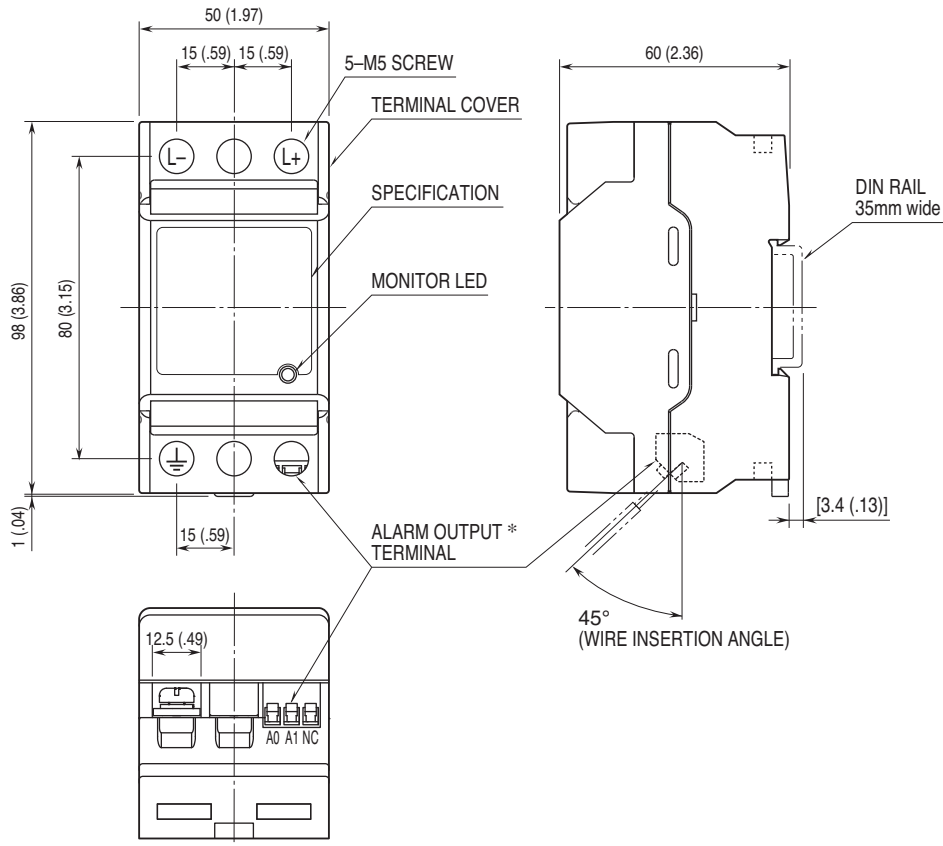

* Only for 'Alarm output' code 'A.'

SCHEMATIC CIRCUITRY

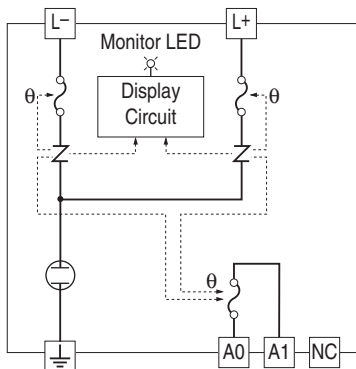

θ: Thermal breaker

Note: Terminals A0 & A1 are available for 'Alarm output' code 'A.'



Specifications are subject to change without notice.