

Paperless Recording System

PAPERLESS RECORDER

(remote I/O modules)

Functions & Features

- 100 msec. storing rate for the max. of 64 points (1 station) with the R3-NE1 module
- Graphic image view helps to recognize measuring points and signal status at a glance
- Data stored in CF Cards and SD cards
- Memory card slot accessible at the front
- Real time monitoring at the host PC via Ethernet
- Dedicated application software to view and analyze the data
- Touch panel operation
- IP 65 front panel

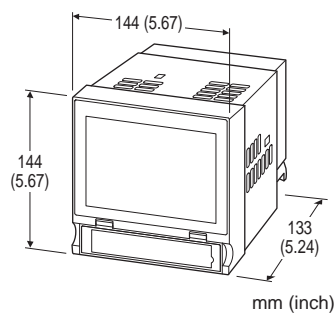

MODEL: 73VR1100-[1]-[2][3]

ORDERING INFORMATION

- Code number: 73VR1100-[1]-[2][3]
Specify a code from below for each [1] through [3].
(e.g. 73VR1100-E-M2/Q)
- Specify the specification for option code /Q
(e.g. /C01/S01/HA)

[1] LANGUAGE

N: Japanese
E: English

[2] POWER INPUT

AC Power

M2: 100 - 240 V AC (Operational voltage range 85 - 264 V, 47 - 66 Hz)

(CE not available for desktop type)

DC Power

R: 24 V DC

(Operational voltage range 24 V ±10 %, ripple 10 %p-p max.)

[3] OPTIONS

blank: none

/Q: With options (specify the specification)

SPECIFICATIONS OF OPTION: Q (multiple selections)

COATING (For the detail, refer to M-System's web site.)

/C01: Silicone coating

/C02: Polyurethane coating

/C03: Rubber coating

TERMINAL SCREW MATERIAL

/S01: Stainless steel

INSTALLATION

/HA: Desktop type (with handle and feet)

(Desktop type cannot be mounted on a panel surface.)

The handle and rubber feet cannot be detached.)

RELATED PRODUCTS

Please refer to data sheets for the respective models.

- PC Recorder R1M, R2M, R1MS, RZMS series

- Remote I/O R3 series

Ethernet (Modbus/TCP) Interface Module (model: R3-NE1)

Modbus Interface Module (model: R3-NM1)

- Remote I/O R5 series

Ethernet (Modbus/TCP) Interface Module (model: R5-NE1)

Modbus Interface Module (model: R5-NM1)

- Modbus I/O Module (model: R7M)

- Ethernet I/O Module, Modbus/TCP (model: R7E)

R7 Configurator Software (model: R7CON) To connect with

R7M series, change Modbus Communication Parameters of the R7M by using R7CON and the special cable.

- Multi Power Monitor (model: 53U)

- Ethernet Tower Light (Model: IT60RE)

Lamps and buzzer are turned on/off in combination with alarm output of 73VR1100.

- Ethernet Communication Adaptor (model: 72EM2-M4)

■ Memory card

A memory card is required to store data in the 73VR1100.

Available for purchase from M-System. Consult M-System.

M-System will not guarantee the product's described

performance if a memory card other than purchased from M-System, or specified below, is used.

- CF Card

1. Manufacturer: Hagiwara Solutions

Model No.: MCF10P-xxxxS

Capacity: 128 MB through 1 GB

(CFI-xxxxDG ... discontinued)

2. Manufacturer: Apacer Technology

Model name: CFC III

Model No.: AP-CFxxxE3ER-ETDNRK

Capacity: 256 MB through 1 GB

Part No.: 81.2A010.1H34C (256 MB)



81.2B010.1H34C (512 MB)

81.2E010.1H34C (1 GB)

(AP-CFxxxxE3ER-ETNDNR ... discontinued)

• SD Card (Compatible with 73VR1100 Ver.5.03.xx or later)

Manufacturer: Hagiwara Solutions

Model No.: NSD6-004GH

(NSDA-004GT, NSDA-004GL ... discontinued)

SD/CF Conversion Adapter is required to use SD card. There are some restrictions on using SD card. For details, refer to the instruction manual.

• SD/CF Conversion Adapter (recommended):

DeLOCK adaptor CF II to SDHC,SDXC, 61796

Note: Refer to the data sheets of the respective models.

PACKAGE INCLUDES...

• 73VR Application Software CD (model: 73VRPAC2)

• Mounting brackets (two)

(/HA: Not included for desktop type)

GENERAL SPECIFICATIONS

Construction: Panel mount type or desktop type

Degree of protection: IP65; applicable to the front panel of the recorder with single mounting according to the specified panel cutout (/HA: Desktop type cannot be mounted on a panel surface)

■ CONNECTION

Power input, alarm output, RUN contact output: M3 separable screw terminal (torque 0.5 N·m)

Screw terminal: Nickel-plated steel (standard) or stainless steel

Ethernet: RJ-45 Modular Jack

RS-485: Euro type connector terminal

Transmission media: Shielded twisted-pair cable (CPEV-S 0.9 dia.)

Wire diameter: 0.14 to 1.5 mm² or AWG 26 to AWG 16 for both stranded and single core wires. Use pin terminals with stranded wires.

■ MATERIALS

Enclosure: Steel

Bezel: Flame-resistant resin (black)

Front filter: Transparent resin

Isolation: Alarm output to RUN output to power to Ethernet to FG or RS-485

■ INDICATORS

RUN output indicator LED: Green light turns on in normal conditions; off in an abnormality.

Power indicator LED: Green light turns on when the power is supplied.

■ INTERFACE

Ethernet: 10BASE-T / 100BASE-TX automatically switched; Conforms to IEEE 802 (10BASE-T) or IEEE 802.3 (100BASE-

TX)

IP address: 192.168.0.1 (factory default setting)

Subnet mask: 255.255.255.0 (factory default setting)

Default gateway: None (factory default setting)

CF Card slot: Type I; for use with the cards' operating voltage 3.3 V

USB: Conforms to Version 1.1

■ ALARM / RUN OUTPUT

Rated load: 250 V AC @ 0.5 A (cos ϕ = 1)

(For desktop type CE conformity: < 50 V AC)

30 V DC @ 0.5 A (resistive load)

Maximum switching voltage: 250 V AC or 30 V DC

Maximum switching power: 250 VA or 150 W

Minimum load: 1 V DC @ 1 mA

Mechanical life: 2 × 10⁷ cycles (rate 300/min.)

External protection is recommended when driving an inductive load.

RUN output contact: ON in normal conditions; OFF in errors (CPU error, application errors)

Alarm output contact: Specified in the application software

■ DISPLAY

Display device: 5.5-inch TFT LCD

Display colors: 256

Resolution: 320 × 240 pixels

Pixel pitch: 0.12 × 0.35 mm

Note: The backlight can be replaced in M-System factory.

The LCD must be replaced at the same time.

EXTERNAL INTERFACE

■ Modbus RTU

Configuration: Half-duplex, asynchronous, no procedure

Standard: Conforms to TIA/EIA RS-485-A

Max. transmission distance: 500 meters

Transfer rate: 38400 bps

Data bit: 8

Parity bit: Odd

Stop bit: 1

Max. node number: 15 (except the master)

Transmission media:

Shielded twisted-pair cable (CPEV-S ϕ 0.9)

Terminating resistor: incorporated

INSTALLATION

Power input

•AC:

Approx. 15 VA at 100 V

Approx. 20 VA at 240 V

•DC: 8 W or 340 mA

Operating temperature: 0 to 50°C (32 to 122°F)

Display quality (e.g. decreased contrast) may deteriorate when the recorder is used for a long time in an environment



exceeding 50°C. However, it is only a temporary phenomenon. When the recorder is back in normal temperature, full legibility is recovered. No damage in performance.

Operating humidity: 30 to 85 %RH (non-condensing)

Allowable dust particles: 0.1 mg/m² (no conductive particles)

Corrosive gas: Not allowed

Mounting: Panel flush mounting (except desktop type)

Panel cutout dimensions: 137 × 137 mm (5.39" × 5.39")

Weight: 1.7 kg (3.7 lb)

Caution: Use of UPS (switching time: without delay, output: sine waveforms) is recommended to prevent data loss or CF card damage by a loss of power during recording.

PERFORMANCE

Calendar clock accuracy: Monthly deviation 3 minutes at 25°C

Insulation resistance: ≥ 100 MΩ with 500 V DC

Dielectric strength: 500 V AC @ 1 minute

(alarm output to RUN output to power or FG or RS-485)

AC powered:

2000 V AC @ 1 minute (power to FG or Ethernet or RS-485)

500 V AC @ 1 minute (FG or RS-485 to Ethernet)

DC powered:

1250 V AC @ 1 minute (power to FG or Ethernet or RS-485)

500 V AC @ 1 minute (FG or RS-485 to Ethernet)

STANDARDS & APPROVALS

CE conformity:

(M2 AC power of desktop type does not conform to EC directive)

EMC Directive (2004/108/EC)

EMI EN 61000-6-4: 2007/A1: 2011

EMS EN 61000-6-2: 2005

Low Voltage Directive (2006/95/EC)

EN 61010-1: 2010

Installation Category II

Pollution Degree 2

Alarm output to RUN output to power to FG or Ethernet or

RS-485: Reinforced insulation (300 V)

APPLICATION SOFTWARE CD

■ **73VRPAC2 (included in the product package)**

• 73VR1100 Builder Software: Model 73VR11BLD

Used to configure parameters on the PC.

- Parameter configurations can be downloaded to the recorder via Ethernet.

- Present setting on the 73VR1100 can be uploaded and displayed on the PC.

- Configuration files can be converted into CSV.

• 73VR Data Viewer: Model 73VRWV

Used to show and analyze recorded data on the PC.

- Data stored in the CF Card can be called up on the PC screen via the CF Card Reader.



- Data stored in the CF Card can be sent by FTP and called up on the PC screen.
 - Various analyzing functions
 - Data, alarm history and comment files can be converted into CSV.
 - PC Recorder Software: Model MSR128-V6
- The 73VR1100 data can be sampled and stored in real time via Ethernet by the MSR128-V6.

- Instruction Manuals
- 73VR1100 users manual
- 73VR11BLD users manual
- 73VRWV users manual
- MSR128-V6 users manual

PC REQUIREMENTS (provided by the user)

• 73VR1100 Builder Software: Model 73VR11BLD

OS	Windows XP SP2, SP3 or Windows Vista Business 32bits or Windows 7 Professional 32 bits Note: Proper software functions may not be ensured under certain conditions.
Screen area	1024 by 768 pixels
CD-ROM drive	Windows supported CD-ROM drive is used to install the software programs.
Card reader	Used to read/write the CF Card
Mouse	Windows supported
LAN card	LAN card required to connect to Ethernet; 10BASE-T or 100BASE-T cable

• 73VR Data Viewer: Model 73VRWV

OS	Windows XP SP2, SP3 or Windows Vista Business 32 bits or Windows 7 Professional 32 bits Note: Proper software functions may not be ensured under certain conditions.
Screen area	1024 by 768 pixels or higher
Display color	65000 colors (16 bits)
Main memory (RAM)	512MB or higher recommended 2 GB recommended for Windows Vista Business 32 bits or Windows 7 Professional 32 bits
CD-ROM drive	Windows supported CD-ROM drive is used to install the software programs.
Card reader	Used to read/write the CF Card
Mouse	Windows supported (Certain functions of the 73VR may be compromised if the mouse's software driver is not Windows standard.)
LAN card	LAN card required to connect to Ethernet; 10BASE-T or 100BASE-TX cable



• PC Recorder Software: Model MSR128-V6

	NORMAL MODE (storing rates ≥ 500 ms)	HIGH SPEED MODE (storing rates 100 / 200 ms)*1
PC	IBM PC/AT or compatible	
OS	Microsoft Windows XP SP1, SP2, SP3 or Windows Vista Business 32 bits or Windows 7 Professional 32 bits Note: Proper software functions may not be ensured under certain conditions.	
CPU	Pentium III 800 MHz or higher 1GHz higher for Windows Vista, Windows 7	Pentium IV 2.0 GHz or higher
Screen area	1024 by 768 pixels or better resolution	
Display color	65000 colors (16 bits)	
Video memory	2 MB minimum; 4 MB recommended	4 MB minimum
Main memory	256 MB recommended; 1 GB recommended for Windows Vista, Windows 7	512 MB recommended; 1 GB recommended for Windows Vista, Windows 7
Hard disk area	Use an internal hard disk. *2 Max. approx. 100 MB required per day.	Use an internal hard disk. *2 Max. approx. 500 MB required per day.
Printer	Use a printer for Windows. The programs use Standard System Fonts used in Windows. Use a printer driver for Standard System Fonts.	
CD-ROM drive	Used when installing the software program.	
Card reader drive	Used with devices which save data in a Compact Flash Card	
Communication port	RS-232C port (COM1 through COM5) supported LAN card	LAN card by Windows

*1. The 73VR1100 or the 73VR21x cannot be used in High Speed Mode.

*2. External (e.g. SCSI) devices may impair appropriate performance.

EXTERNAL VIEW

■ FRONT VIEW

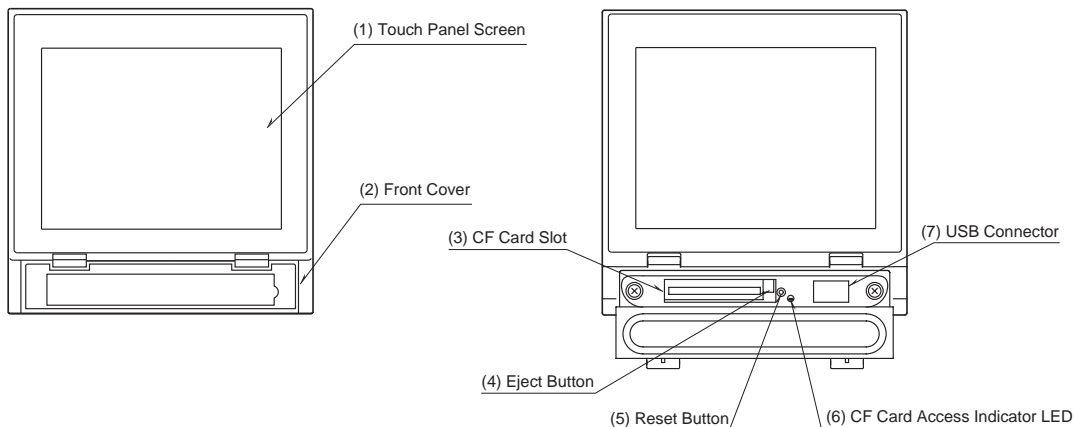

■ REAR VIEW

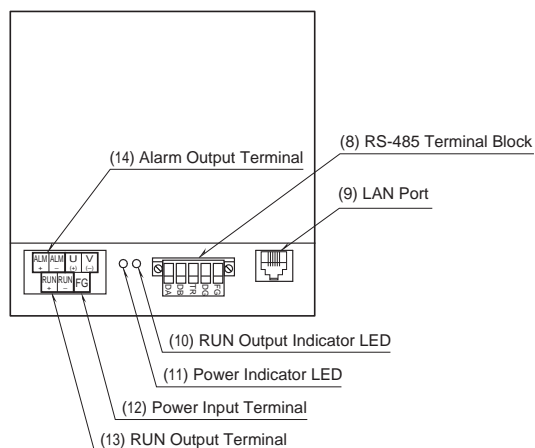

COMMUNICATION CABLE CONNECTIONS

■ R3-NM1, R5-NM1, R7M

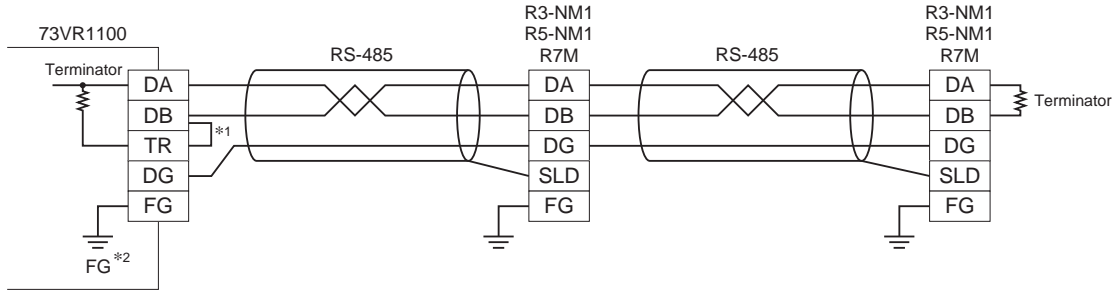

■ PC RECORDER, 53U

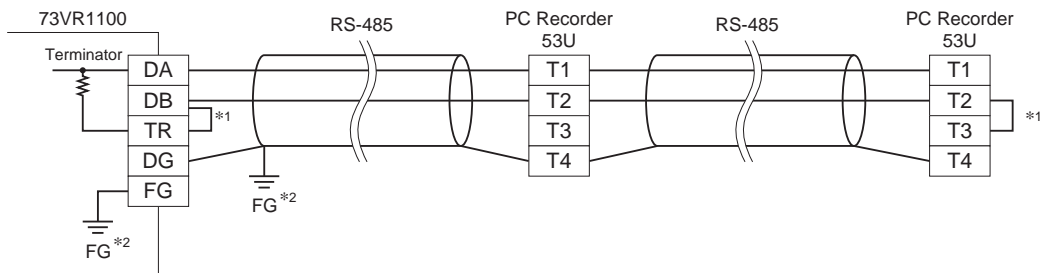

- *1. Internal terminating resistor is used when the device is at the extreme end of a transmission line.
- *2. Install shield cables to all sections and ground them at a single point.

CONNECTION DIAGRAM

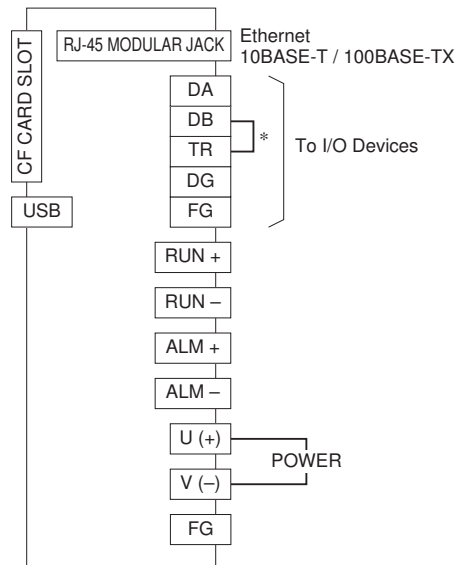

*Short across these terminals when the device is at the extreme end of a transmission line.



DIMENSIONS unit: mm (inch)

• Panel mount type

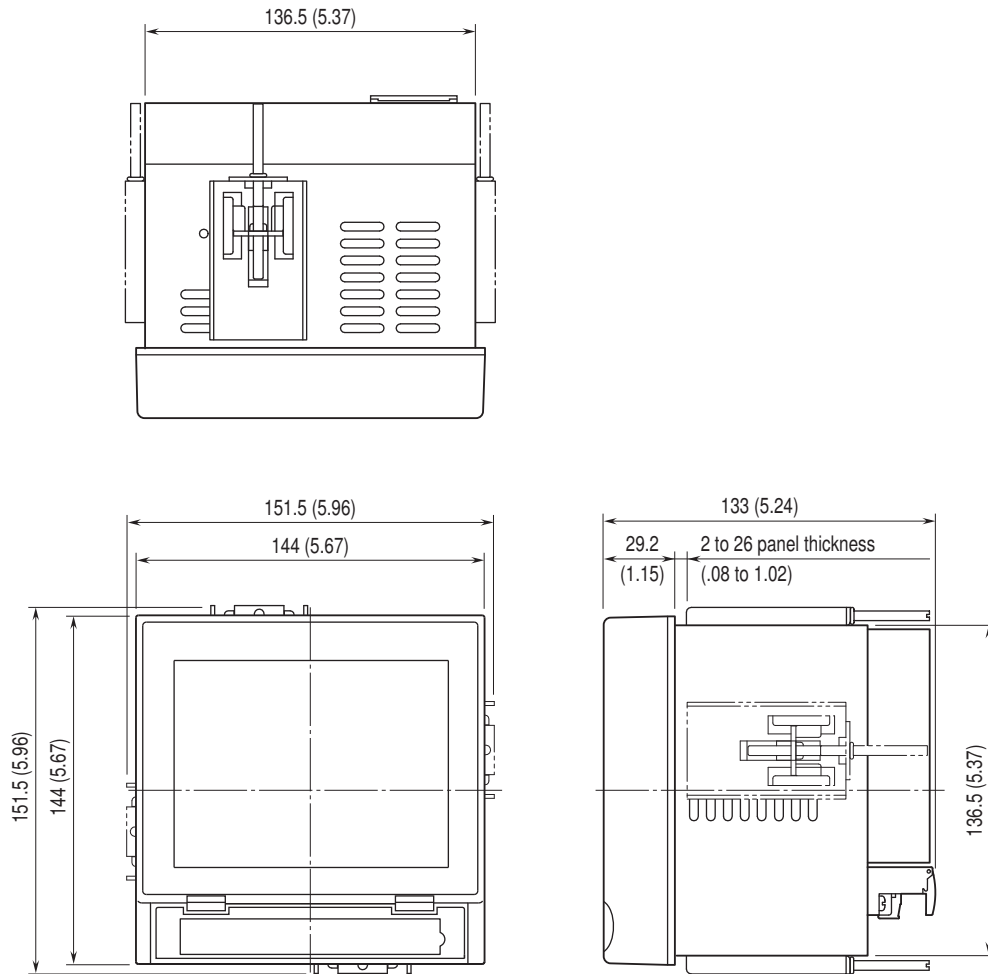

Attach the mounting bracket either on the top/bottom or on the sides.



• Desktop type

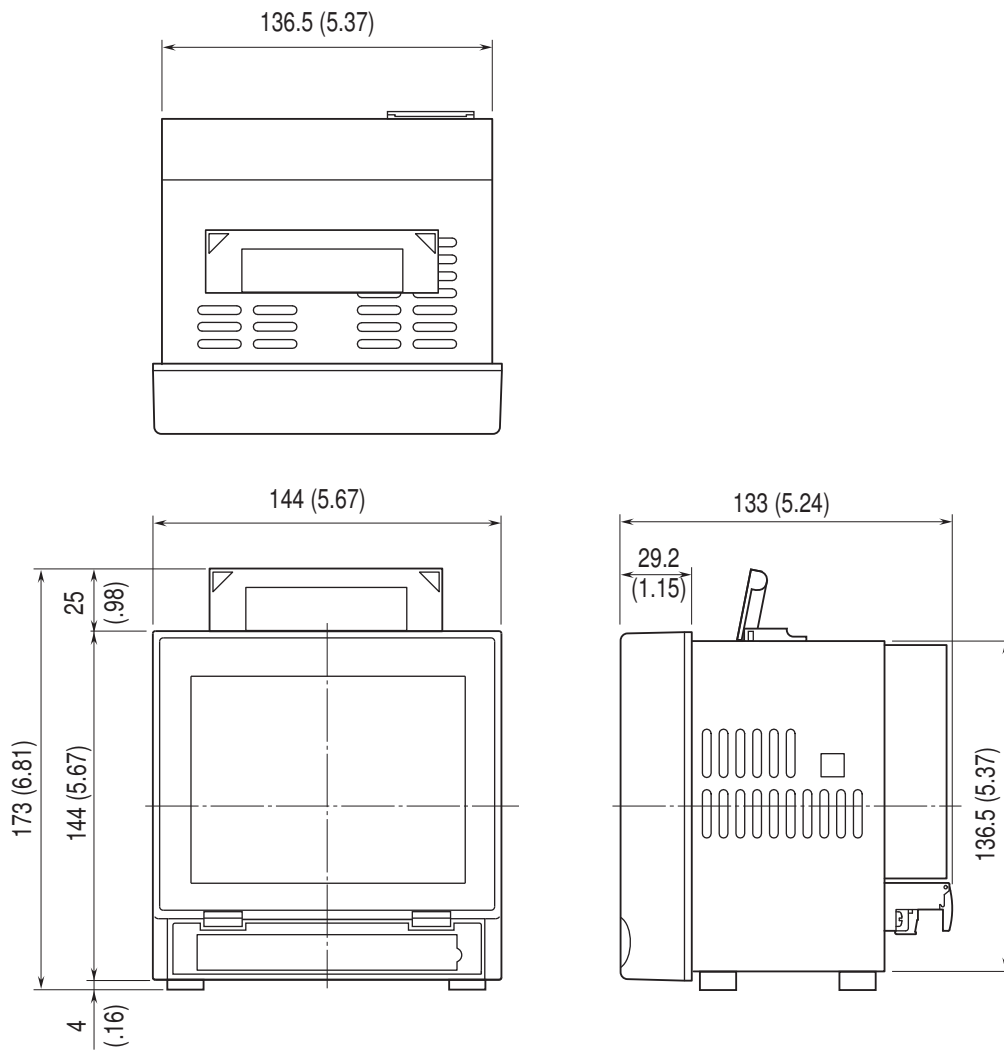

PANEL CUTOUT (unit: mm)

Usable panel thickness: 2 - 26 mm (0.08" - 1.02")

SINGLE MOUNTING

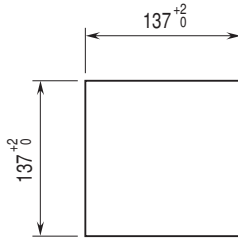

Number	L ₀ ⁺² (mm)
2	282
3	426
4	570
5	714
6	858
7	1002
8	1146
9	1290
10	1434
n	(114 × n) - 6

Notes

1. Dimensional tolerance ±3% unless otherwise specified. (±0.3 mm for <10 mm)
2. Desktop type cannot be mounted on a panel surface.

VERTICAL CLUSTERED MOUNTING (max. 3 units)

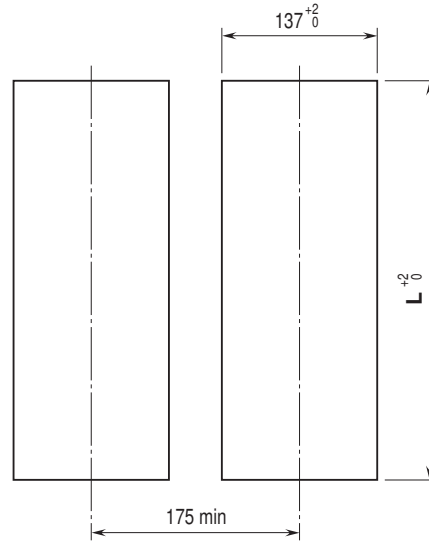

HORIZONTAL CLUSTERED MOUNTING

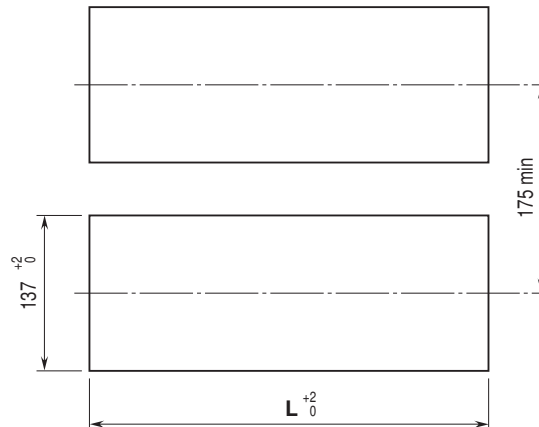

SOFTWARE FUNCTIONS

■ NUMBER OF INPUT PEN POINTS

High speed mode: 64 points

Normal mode: 128 points

Function pen points are included in the above figures.

■ TYPE OF I/O DEVICES

High speed mode: R3-NE1

Normal mode: R1M-GH2, R1M-J3, R1M-A1, R1M-D1, R1M-P4, R1MS-GH3, R2M-2G3, R2M-2H3, RZMS-U9, R3-NE1, R3-NM1, R5-NE1, R5-NM1, R7E, R7M, 53U, IT60RE

■ NUMBER OF I/O DEVICES

Ethernet

High speed mode: 1 station

Normal mode: 2 stations; Max. 15 nodes are connectable to one 72EM2-M4 station.

RS-485: 15 nodes

■ DATA STORING METHOD

Normal: Recording is manually initiated and stopped. Data is continuously stored while the recording is on.

Auto: Recording is automatically initiated and stopped at a predefined time.

Event recording: The recorder detects an external event by trigger signal, and stores preset number of samples (max. 1200 respectively) before and after the moment of event.

Remote trigger: Data is automatically recorded while the external trigger condition (input) is true.

■ STORING RATE

High speed mode: 100 msec.

Normal mode: 500 msec., 1, 2, 5, 10 seconds, 1 minute, 10 minutes (Actual storing rate depends upon the number of



I/O devices. Contact M-System for more information.)
[Example] Max. number of I/O devices that ensures 500 msec. storing intervals under the following conditions:
Data cycle priority on alarm, RS-485 connection, no trigger or alarm setting

R1M-GH2: 10

RZMS-U9: 2

R3-NE1: 1 (128 channels, analog input only)

■ DATA STORAGE

Data file: Stores momentary values in the storing rate and their calculation result.

Alarm history file: Records time index information when alarms are triggered and reset.

Oldest data is overwritten with new data when the number of records reaches its limit.

Comment history file: Records comments written in trend views with time index. Oldest data is overwritten with new data when the number of records reaches 1000 files.

Configuration file: Stores the 73VR1100 setting.

File format: Binary

Oldest measured data is overwritten with new data or data recording is stopped when the card memory is full.

■ ALARM

• Analog Alarm

Alarm setpoints: Max. 4 points per channel

Alarm type: High / Low

Deadband: Set in engineering unit values

Output: Remote output devices

• Discrete Alarm

Alarm type: ON / OFF

Delay time: Selectable

Output: Remote output devices

Data Storage: Trigger time, reset time, pen number and tag name, alarm message

Number of stored alarm events: Depends upon the CF Card capacity.

128 MB: 250 events

256 MB: 500 events

512 MB or 1 GB: 1000 events

■ CALCULATION FUNCTIONS

Function pen points

High speed mode: 32 points

Normal mode: 32 or 64 points selectable

Operations

Arithmetic: Addition/subtraction, Multiplication, Division

Logical: AND, OR, NOT, XOR

Mathematical: Square root extractor, Power

Accumulation: Analog accumulation, Pulse accumulation (per time unit)

Filter: Moving average, First order lag

Hold: Peak (maximum) hold (tracking increasing signal),
Peak (minimum) hold (tracking decreasing signal)

F value: F value

Anemoscope (16 directions)

Alarm: Alarm trip can be programmed for calculated results.

■ DATA DISPLAY FUNCTIONS

• Trend View

Chart direction: Perpendicular or horizontal

Number of pens displayed: 2, 4, 6, 8 per view

Number of display views: 4

Chart speed:(Chart speed is described as number of pixels to plot single data sample.)(pixel(s)/samples)

• 4, 1, 1/5, 1/32

• 1/160, 1/480 or 1/960 (Not selectable with 100 msec. storing rate)

Display rate:(Common setting to all views)

1, 2 or 5 sec.

Pen thickness: Normal and wide

Digital indicator: Shows momentary value.

Alarm indicator: Shows alarm status of the channels displayed on the screen.

Comment: Shows comments entered manually.

Scale: Linear and square root; Switchable to the engineering unit scale.

• Bargraph View

Bargraph direction: Perpendicular or horizontal

Number of pens displayed: 2, 4, 6, 8 per view

Number of display views: 4

Display rate:(Common setting to all views)

1, 2 or 5 sec.

Digital indicator: Shows momentary value.

Alarm indicator: Shows alarm status of the channels displayed on the screen.

Scale: Linear and square root;

Switchable to the engineering unit scale.

• Overview

Number of pens displayed: 2, 4, 6, 8, 16 per view

Number of display views: 64

Display rate:(Common setting to all views)

1, 2, or 5 sec.

Alarm indicator: Shows alarm status and date/time of the last alarm trip and reset for the channels displayed on the screen.

• Graphic View

Number of display views: 2

Display rate:(Common setting to all views)

1, 2 or 5 sec.

Background image file format: .bmp

Background image size: 320 by 240 pixels

Background image color: 256

Number of components displayed: Max. 64 per view

Retrieve View: Shows data stored in the CF Card.

Number of pens displayed: 2, 4, 6, 8 per view

Number of display views: 4



Data search: Scrolling the chart, specifying a specific time index, or searching by max./min. values.

- **Alarm History View:** Shows data stored in the alarm history file.

Number of displayed alarm events: 16

Number of display views: 1

Display update: Automatically updated by a new event

Data search: Scrolling the view or specifying a specific time index.

Jump: Scroll the view to an alarm event to show the relevant data on Retrieve View.

- **Comment History View:** Shows data stored in the comment history file.

Number of displayed alarm events: 16

Number of display views: 1

Data search: Scrolling the view or specifying a specific time index.

Jump: Scroll the view to a comment to show the relevant data on Retrieve View.

■ ETHERNET COMMUNICATION

- **Dedicated Protocol**

Real time communication: Transmits specific data to a host PC installed with the PC Recorder Software (model: MSR128). Max. 2 hosts.

FTP communication: Transmits data stored in the CF Card using the FTP protocol to a host PC by the 73VR Data Viewer (model: 73VRWV) installed in it. Data can be transmitted even during recording.

Download, Upload: Software configurations created on the 73VR1100 Configuration Builder (model: 73VR11BLD) can be downloaded to the 73VR1100. The configuration set up on the 73VR1100 can be uploaded and displayed on the 73VR11BLD.

- **Modbus Protocol**

Protocol: Modbus/TCP

Port No.: 502 (fixed)

IP address: Set on the recorder

Subnet mask: Set on the recorder

Default gateway: Set on the recorder

Max. number of 73VR1100 connected simultaneously: 2

Supported Function Codes

CODE	NAME	FUNCTION
01	Read Coil Status	Reads DO
02	Read Input Status	Reads DI
04	Read Input Register	Reads Input Register
11	Fetch Communication Event Counter	Reads Status Word and Event Counter from Comm. Event Counter

Exception Response

CODE	NAME	FUNCTION
01	Illegal Function	Function Not supported
02	Illegal Data Address	Specified address does not exist

Supported Function Codes

Data storing rate 100 msec.

	ADDR.	TYPE	NAME
Coil (0X)	1		Discrete output (pen 1, relay 1)
	2		Discrete output (pen 1, relay 2)
	3		Discrete output (pen 1, relay 3) (Unused with discrete alarm)
	4		Discrete output (pen 1, relay 4) (Unused with discrete alarm)
	:		:
	255		Discrete output (pen 64, relay 3) (Unused with discrete alarm)
	256		Discrete output (pen 64, relay 4) (Unused with discrete alarm)
	257		Discrete output (alarm output terminal)
Input Status (1X)	1 thr. 64		Input or function data (discrete)
Input Register (3X)	1 thr. 128	I or F	Input or function data (analog)

Data storing rate 500 msec.

	ADDR.	TYPE	NAME
Coil (0X)	1		Discrete output (pen 1, relay 1)
	2		Discrete output (pen 1, relay 2)
	3		Discrete output (pen 1, relay 3) (Unused with discrete alarm)
	4		Discrete output (pen 1, relay 4) (Unused with discrete alarm)
	:		:
	511		Discrete output (pen 128, relay 3) (Unused with discrete alarm)
	512		Discrete output (pen 128, relay 4) (Unused with discrete alarm)
	513		Discrete output (alarm output terminal)
Input Status (1X)	1 thr. 128		Input or function data (discrete)
Input Register (3X)	1 thr. 256	I or F	Input or function data (analog)

■ OTHER FUNCTIONS

- **Operation Lockout**

With a password setting, unauthorized operations on the



Trend View, Bargraph View and Overview can be locked out.

• **Data File Used Volume Information**

A bargraph with % indication is provided on the screen to show how much percent of the data file memory has been used up.

0 - 49 % used: Green bargraph

50 - 79 % used: Amber bargraph

80 - 100 % used: Red bargraph

• **Hot Swapping of the CF Card**

The CF Card is hot swappable: removable during data recording. However, there may be a slight disturbance in storing rate when the card is inserted.

• **Screen Saver**

The backlight is automatically turned off if the screen is untouched for a certain time period.

• **Writing/Reading Setting**

The recorder's present setting can be stored in a USB flash-memory. Setting stored in the memory can be read in to the 73VR1100.

■ **SELECTABLE REMOTE I/O MODULES**

• **PC Recorder (R1, R2, RZ) Series**

SIGNAL TYPE	MODELS
DC voltage input	R1M-GH2, R1MS-GH3, R2M-2G3, RZMS-U9
Thermocouple input	R1M-GH2 R1MS-GH3, R2M-2H3, RZMS-U9
RTD input	R1M-J3, RZMS-U9
Potentiometer input	R1M-J3, RZMS-U9
Contact input	R1M-A1
Contact output	R1M-D1
Totalized pulse input	R1M-P4, R1M-A1
Pulse input	R1M-P4

• **R3 Series Remote I/O**

SIGNAL TYPE	MODELS
DC voltage input	R3-SV4, R3-SV4A, R3-SV4B, R3-SV4C, R3(Y)-SV8, R3-SV8A, R3-SV8B, R3-SV8C, R3(S/Y)-SV8N, R3-SV16N, R3Y-SV16
DC current input	R3-SS4, R3(Y)-SS8, R3(S/Y)-SS8N, R3(Y)-SS16N
Thermocouple input	R3-TS4, R3-TS8
RTD input	R3-RS4, R3(S)-RS4A, R3(Y)-RS8, R3-RS8A, R3-RS8B
Universal input	R3-US4
Discrete input	R3(S/Y)-DA16, R3(Y)-DA16A, R3-DA16B, R3-DA32A, R3-DA64A
Discrete output	R3(Y)-DC16, R3-DC16A, R3-DC16B, R3-DC16C, R3-DC32A, R3-DC32C, R3-DC64A, R3-DC64C
Discrete I/O	R3(S)-DAC16*, R3(S)-DAC16A*
4 - 20mA input with excitation supply	R3(Y)-DS4, R3-DS4A, R3-DS8N
Potentiometer input	R3-MS4, R3(Y)-MS8
CT input	R3-CT4
AC current input with clamp-on current sensor	R3-CT4A**, R3-CT4B**, R3-CT4C, R3-CT8A**, R3-CT8B**, R3-CT8C
PT input	R3-PT4
Zero-phase current input	R3-CZ4
AC power input	R3-WT4, R3-WT4A, R3-WT4B, R3-WTU
High speed pulse input	R3-PA4
Encoder input	R3-PA2
Totalized pulse input	R3-PA4A, R3-PA4B, R3(Y)-PA16, R3(S)-PA8
Strain gauge input	R3-LC2
Alarm	R3-AD4, R3-AR4, R3-AS4, R3-AS8, R3-AT4, R3-AV4, R3-AV8
Gateway	R3-GC1, R3-GD1, R3-GE1, R3-GFL1, R3-GM1

* Only continuance output mode is available.

** Data range must be setup with the PC Configurator Software R3CON and the dedicated cable.



• R5 Series Remote I/O

SIGNAL TYPE	MODELS
DC voltage input	R5-SV, R5T-SV
DC current input	R5-SS, R5T-SS
Thermocouple input	R5-TS, R5T-TS
RTD input	R5-RS, R5T-RS
Discrete input	R5-DA4, R5T-DA4, R5-DA16
Discrete output	R5-DC4, R5T-DC4, R5-DC16
4 – 20mA input with excitation supply	R5-DS, R5T-DS
Potentiometer input	R5-MS
CT input	R5T-CT
AC current input with clamp-on current sensor	R5T-CTA*, R5T-CTB*
PT input	R5T-PT

*Data range must be setup with the the PC Configurator Software R5CON and the dedicated cable.

• Multi Power Monitor

SIGNAL TYPE	MODELS
AC power/energy	53U*

*Choose 'Modbus' option. Only 1 DO can be used for alarm output.

• ETHERNET Tower Light

SIGNAL TYPE	MODELS
Discrete output	IT60RE, IT40SRE, IT50SRE, IT60SRE

• R7M Series Remote I/O*

SIGNAL TYPE	MODELS
DC voltage/current input	R7M-SV4
Thermocouple input	R7M-TS4
RTD input	R7M-RS4
Potentiometer input	R7M-MS4
CT input	R7M-CT4E
Discrete input	R7M-DA16
Discrete output	R7M-DC16A, R7M-DC16B, R7M-DC8C
Discrete input (Extension)	R7M-EA8, R7M-EA16
Discrete output (Extension)	R7M-EC8A, R7M-EC16A, R7M-EC8B, R7M-EC16B

*Must be setup with R7X Configurator and the dedicated cable.

• R7E Series Remote I/O

SIGNAL TYPE	MODELS
DC voltage/current input	R7E-SV4
Thermocouple input	R7E-TS4
RTD input	R7E-RS4
Potentiometer input	R7E-MS4
CT input	R7E-CT4E*
Discrete input	R7E-DA16
Discrete output	R7E-DC16A, R7E-DC16B
Discrete input (Extension)	R7E-EA8, R7E-EA16
Discrete output (Extension)	R7E-EC8A, R7E-EC16A, R7E-EC8B, R7E-EC16B

*Must be setup with R7X Configurator and the dedicated cable.



■ STORABLE TIME DURATION IN 1GB CF CARD

RATE	8 ch input	16 ch input	32 ch input	64 ch input	128 ch input
0.1 seconds	27 days, 16 hours	15 days, 8 hour	8 days, 8 hours	4 days, 8 hours	- - -
0.5 seconds	142 days	77 days	40 days	20 days, 16 hours	14 days
1 seconds	277 days	154 days	81 days, 16 hours	42 days	28 days, 8 hours
10 seconds	7 years, 222 days	4 years, 83 days	2 years, 86 days	1 years, 55 days	213 days
1 minute	10 years minimum	10 years minimum	10 years minimum	6 years, 335 days	3 years, 172 days

--- : Not Applicable

Note 1) Data are calculated ones, and thus not guaranteed.

Note 2) Assuming 4 bytes per data per channel.

Note 3) A year is calculated as 365 days.



SYSTEM CONFIGURATION EXAMPLES

R1M, R2M, RZMS

[Example 1]

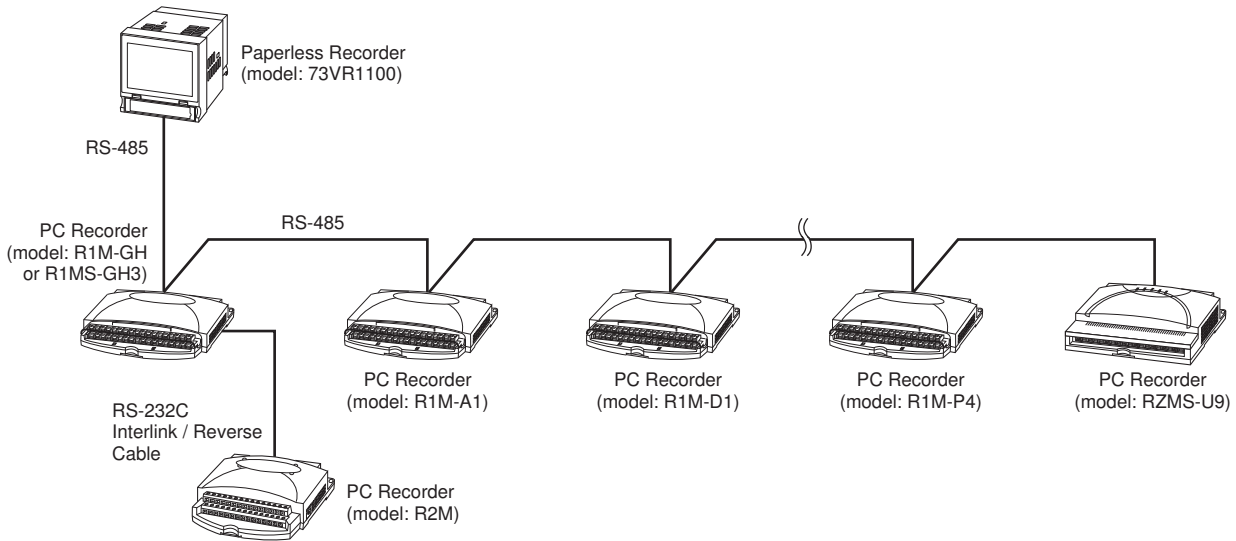

[Example 2]

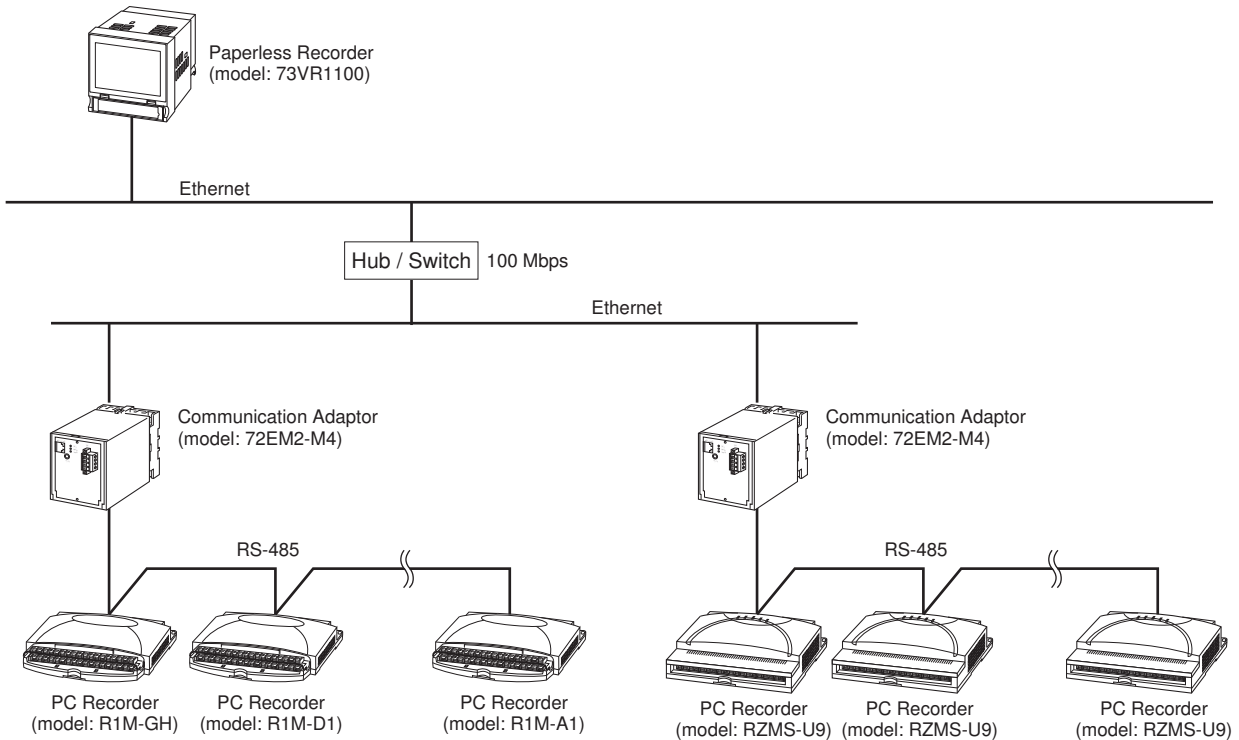

[Remarks]

1. Use a dedicated network for the 73VR1100 and its input devices.
2. The sampling rate depends upon the number of devices to be connected.



R3, R5 SERIES

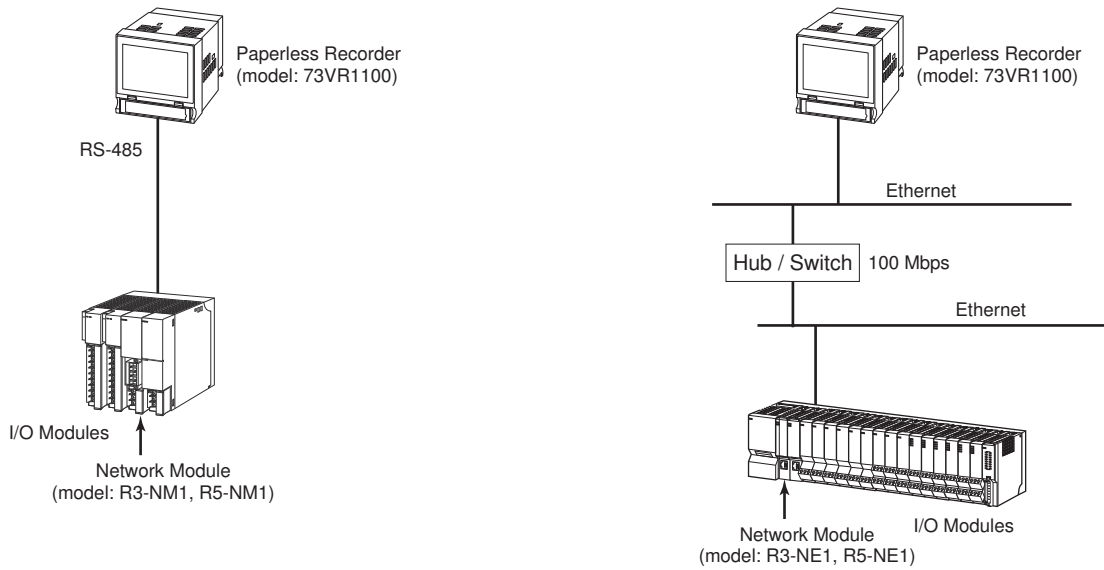

[Remarks]

1. Use a dedicated network for the 73VR1100 and its input devices.
2. The sampling rate depends upon the number of devices to be connected for the R3 series.
3. Use of a switch/hub via straight type cables is recommended to connect the R3-NE1 or the R5-NE1 to the 73VR1100.

R7E

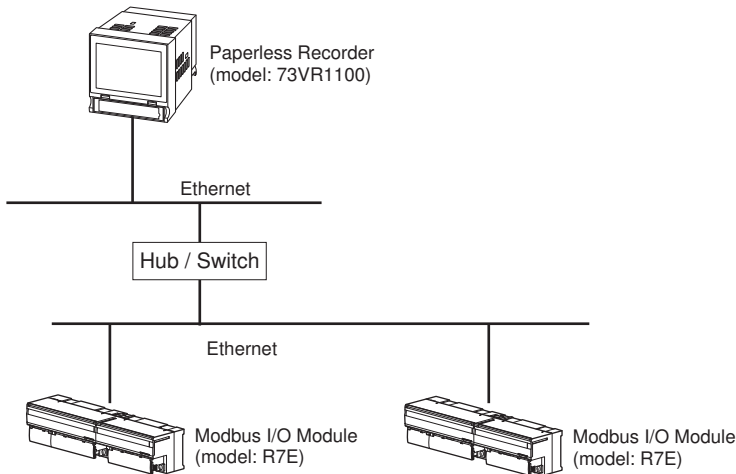

R7M

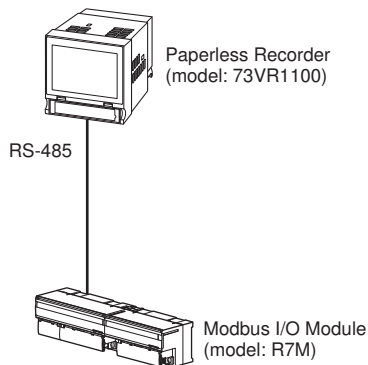

53U

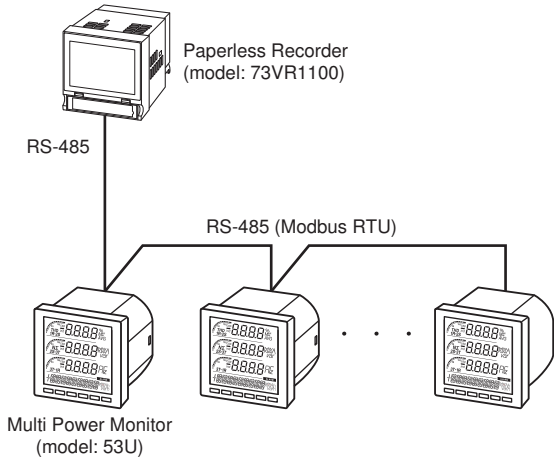

IT60RE (R3 applied on input units)

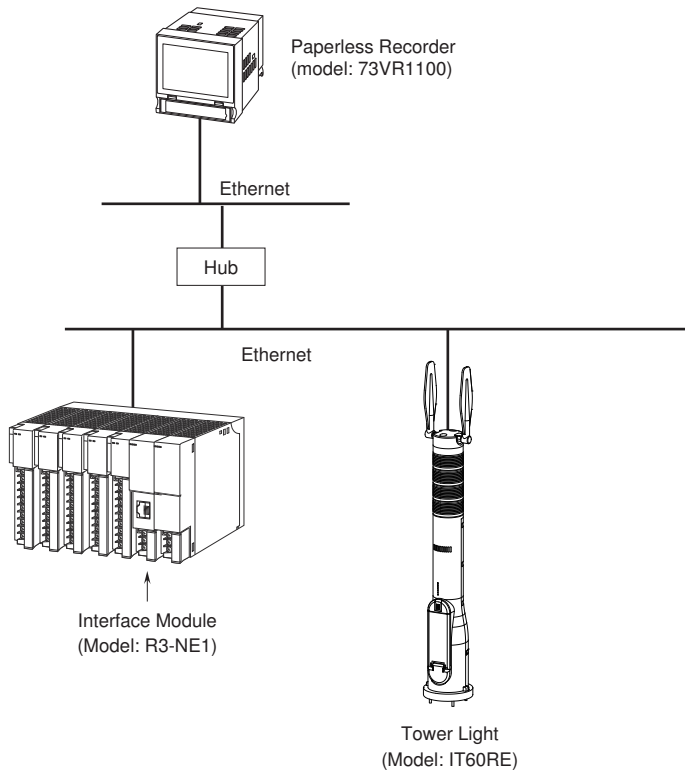

MSR128

• I/O devices connected to RS-485

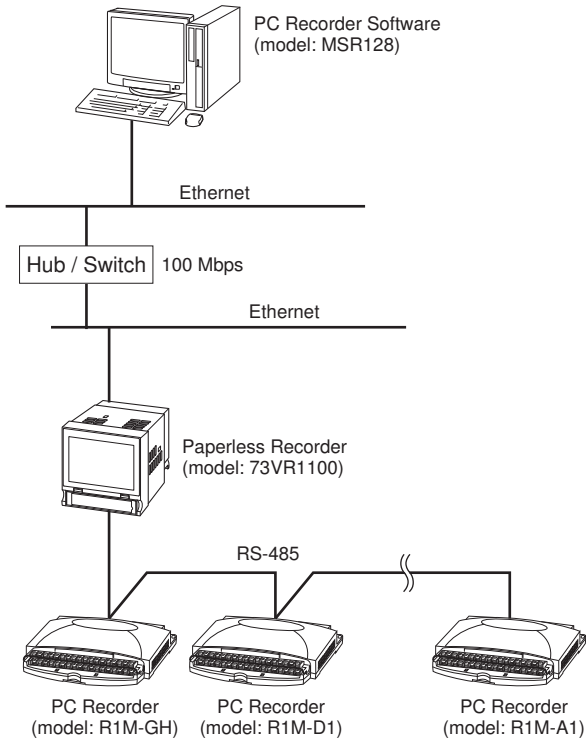

• Transferring data from the CF Card

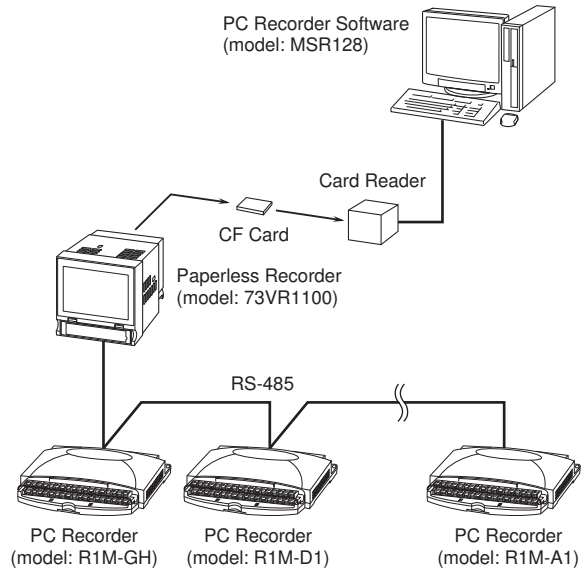

• I/O devices connected to Ethernet

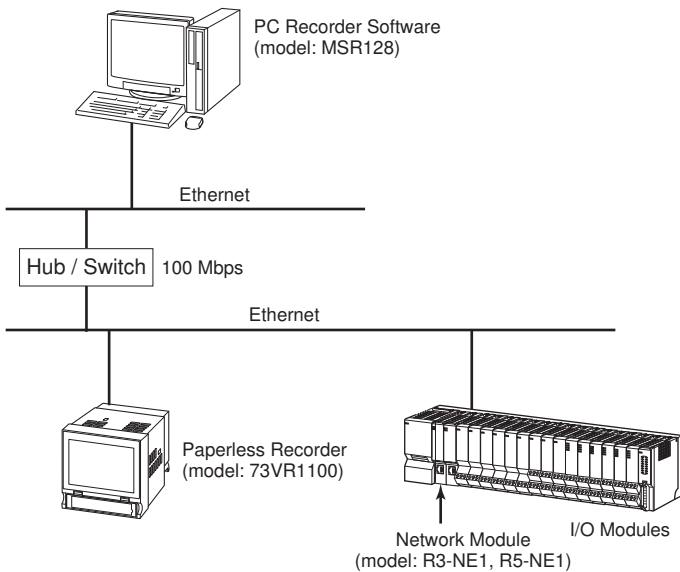

[Remarks]

1. Use a dedicated network for the 73VR1100 and its input devices.
2. Use of a hub/switch via straight cables is recommended to connect the 73VR1100 to the PC.
3. The storing intervals of 100 msec. and 200 msec. are not applicable to the above configuration.



Specifications are subject to change without notice.

