

## Power Transducer Series

### MULTI POWER MONITOR

(4 digital displays)

#### Functions & Features

- Measures simultaneously several variables of a heavy-current power system: current, voltage, active, reactive and apparent power, active and reactive energy, power factor, frequency, etc.
- All measured values, counter values, display mode, setting data are stored in the non-volatile memory at the power off
- Parameters are programmable using the front keys or the PC via infrared interface
- Mounted using M5 screws or mounting brackets
- 60-segment bargraph
- Displayed measurands are freely selectable
- Open collector output for alarm or energy count
- Loop test output

#### Typical Applications

- Multi-functional power monitor incorporated in an electric device: saves space, wiring works, and cost

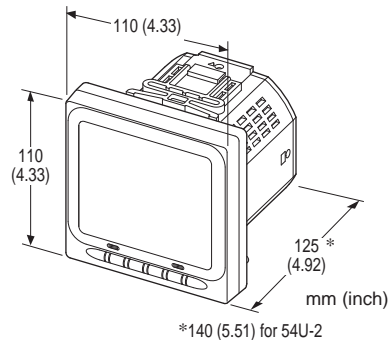

### MODEL: 54U-[1][2][3][4]-AD4[5]

#### ORDERING INFORMATION

- Code number: 54U-[1][2][3][4]-AD4[5]
- Specify a code from below for each [1] through [5].  
(e.g. 54U-1211-AD4/Q)
- Specify the specification for option code /Q  
(e.g. /SET)

#### [1] CONFIGURATION

- 1: Single-phase / 2-wire and 3-wire, 3-phase / 3-wire
- 2: Single-phase / 2-wire and 3-wire,  
3-phase / 3-wire and 4-wire

#### [2] INPUT

- 1: 480 V / 1 A AC
- 2: 480 V / 5 A AC

#### [3] DISCRETE INPUT

- 0: None  
(‘External Interface’ codes 1, 2, 3, 7 and 8 Not selectable.)
- 1: 24V DC  
(‘External Interface’ codes 4, 5, 6, 9 and A Not selectable.)
- 2: 110V DC  
(‘External Interface’ codes 4, 5, 6, 9 and A Not selectable.)

#### [4] EXTERNAL INTERFACE

- 1: Modbus, Do × 1, Di × 1
- 2: 4 - 20 mA DC × 4, Do × 1, Di × 1
- 3: 1 - 5 V DC × 4, Do × 1, Di × 1
- 4: Modbus, Do × 2
- 5: 4 - 20 mA DC × 4, Do × 2
- 6: 1 - 5 V DC × 4, Do × 2
- 7: 4 - 20 mA DC × 4 (isolated), Do × 1, Di × 1
- 8: 1 - 5 V DC × 4 (isolated), Do × 1, Di × 1
- 9: 4 - 20 mA DC × 4 (isolated), Do × 2
- A: 1 - 5 V DC × 4 (isolated), Do × 2

#### AUXILIARY POWER SUPPLY

- AD4: universal  
100 - 240 V AC (Operational range 85 - 264 V, 50 / 60 Hz) /  
110 - 240 V DC (Operational range 99 - 264 V,  
ripple 10 %p-p max)

#### [5] OPTIONS

##### Language

- blank: Japanese  
/E: English

##### Other Options

- blank: none  
/Q: Option other than the above (specify the specification)

#### SPECIFICATIONS OF OPTION: Q

##### EX-FACTORY SETTING

- /SET: Preset according to the Ordering Information Sheet  
(No. ESU-6487)

#### RELATED PRODUCTS

- Infrared Communication Adaptor (model: COP-IRU)
  - PC configurator software (model: PMCFG)
- Downloadable at M-System’s web site.



## GENERAL SPECIFICATIONS

**Construction:** 110-mm square panel flush mounted

**Degree of protection**

**Front panel:** IP 50

**Terminal block, housing:** IP 30

**Connection**

**Voltage input:** M4 screw terminals (torque 1.4 N·m)

**Current input:** M4 screw terminals (torque 1.4 N·m)

**Output, power:** M3 screw terminals (torque 0.6 N·m)

**Configuration**

**Code 1:** Single phase/2-wire and 3-wire, 3-phase/3- wire balanced/unbalanced load

**Code 2:** Single phase/2-wire and 3-wire, 3-phase/3- wire balanced/unbalanced load, 3-phase/4- wire balanced/unbalanced load

**Housing material:** Flame-resistant resin (black)

**Isolation:** Voltage input to current input to discrete input to network interface or analog output to discrete output to power

Note: Isolated between each analog output for 'External interface' codes 7, 8, 9 and A

**Measured variables**

**Voltage:** 1 - 2, 2 - 3, 3 - 1, 1 - N, 2 - N, 3 - N

**Current:** 1, 2, 3, N

**Active / reactive / apparent power:** 1, 2, 3,  $\Sigma$

**Power factor:** 1, 2, 3,  $\Sigma$

**Frequency**

**Phase angle between voltages:** 1 - 2, 2 - 3, 3 - 1

**Active energy incoming / outgoing:**  $\Sigma$

**Reactive energy inductive / capacitive:**  $\Sigma$

**Apparent energy:**  $\Sigma$

**Active / reactive / apparent power intervals (demand)**

**Current intervals (demand):** 1, 2, 3, N

**Harmonic contents:**  $\Sigma$ , 2nd to 31st

**Voltage:** 1 - 2, 2 - 3, 3 - 1, 1 - N, 2 - N, 3 - N

**Current:** 1, 2, 3, N

**Max. and min. values:** 1 = R, 2 = S, 3 = T

**Infrared communication:** Transmission distance max. 1 meter (for use with the COP-IRU and PMCFG)

■ **DISPLAY:** LCD with LED backlight (LED OFF timer available)

**Signed:** 4 digits, 2 lines

**Energy:** 9 digits, 1 line

**Bargraph:** 1 point (60 segments)

## INPUT SPECIFICATIONS

**Frequency:** 50 / 60 Hz (45 - 65 Hz)

• **Voltage Input**

**Rated voltage**

**Line-to-line (delta voltage):** 480 V

**Line-neutral (phase voltage):** 277 V

**Consumption VA:**  $\leq U_{LN}^2 / 300 \text{ k}\Omega / \text{phase}$

**Overload capacity:** 200 % of rating for 10 sec., 120 % continuous

**Selectable primary voltage range:** 50 - 400 000 V

• **Current Input**

**Rated current:** 1 A or 5 A

**Consumption VA:**  $\leq I^2 \cdot 0.01 \Omega / \text{phase}$

**Overload capacity:** 4000 % of rating for 1 sec., 2000 % for 4 sec., 120 % continuous

**Selectable primary current range:** 1 - 20 000 A

**Operational range**

**Voltage, current, apparent power:**  $\leq 120 \%$  of the rating

**Active / reactive power:** -120 to +120 % of the rating

**Frequency:** 45 - 65 Hz

**Power factor:** -1 to +1

■ **Contact Input:** 24 V DC or 110 V DC

(input resistance 6 k $\Omega$ )

**Detecting voltage:** External 24 V DC  $\pm 10 \%$  or 110 V DC  $\pm 10 \%$

**ON current:**  $\geq 1 \text{ mA}$  ( $\leq 24 \text{ k}\Omega @ 24 \text{ V}$ ,  $\leq 110 \text{ k}\Omega @ 110 \text{ V}$ )

**OFF current:**  $\leq 0.1 \text{ mA}$  ( $\geq 240 \text{ k}\Omega @ 24 \text{ V}$ ,  $\geq 1.1 \text{ M}\Omega @ 110 \text{ V}$ )

**Detecting time:** 10 - 1000 msec.

The status can be monitored on the Modbus; usable to reset energy count or to update average (demand) value.

## OUTPUT SPECIFICATIONS

■ **Network Interface**

**Communication:** Half-duplex, asynchronous, no procedure

**Interface:** Conforms to EIA RS-485

**Max. transmission distance:** 500 meters

**Baud rate:** 1.2 - 38.4 kbps

**Max. number of nodes:** 31 (except the master)

**Protocol:** Modbus RTU

**Node address:** 1 - 247 (factory default setting: 1)

**Parity:** none, even or odd (factory default setting: odd)

**Stop bit:** 1 or 2 (factory default setting: 1)

**Media:** Shielded twisted-pair cable (CPEV-S 0.9 dia.)

■ **DC Current:** 4 - 20 mA DC

**Load resistance:**  $\leq 270 \Omega$

**Measurands converted into analog output:** Voltage, Current, Active / reactive / apparent power, Power factor, Frequency, Harmonic contents

■ **DC Voltage:** 1 - 5 V DC

**Load resistance:**  $\geq 5000 \Omega$

**Measurands converted into analog output:** Voltage, Current, Active / reactive / apparent power, Power factor, Frequency, Harmonic contents

■ **Open Collector**

Programmable for either alarm or energy count.

**Max. rated load:** 130 V DC @50 mA

**Continuous rated load:** 130 V DC @30 mA

**Saturation voltage:** 1.5 V DC



**Measurands applicable to alarm:** Voltage, current, average current (demand), neutral current, frequency, power, average power (demand)

(ON delay, deadband and other parameters are selectable)

**Measurands applicable to count:** Energy;

Pulse rate selectable within

0.1 - 10 000.0 kWh/p, kvarh/p, kVAh/p

interface or analog output to discrete output to power)

500 V AC @1 minute for 'External interface' code 7, 8, 9 and A (between each analog output)

2000 V AC @1 minute (circuits to housing)

## INSTALLATION

### Power consumption

•**AC:** < 8 VA; Less than 13 VA for 'External interface' code 7 and 9

•**DC:** < 4 W; Less than 6 W for 'External interface' code 7 and 9

**Operating temperature:** -10 to +55°C (14 to 131°F)

**Storage temperature:** -20 to +80°C (-4 to +176°F)

**Operating humidity:** 0 to 90 %RH (non-condensing)

**Mounting:** Panel flush mounting (M5 screws (torque 2 N·m) or mounting brackets)

### Weight

**Configuration Code 1:** 500 g (1.1 lb)

**Configuration Code 2:** 525 g (1.16 lb)

## PERFORMANCE

### Accuracy

(at 23°C ±10°C or 73.4°F ±18°F, 45 - 65 Hz)

**Voltage:** (accur.±0.3 %)

Rated voltage at ≥ 100 V

100 V at < 100 V

**Current:** (accur.±0.3 %) of Span 1 A or 5 A

**Power:** (accur.±0.5 %)

Rated voltage/current at ≥ 100 V

Wattage as listed below at < 100 V:

173.2 W (1 A) or 866 W (5 A) for 3 ph/3 w

100 W (1 A) or 500 W (5 A) for 1 ph/2 w

200 W (1 A) or 1000 W (5 A) for 1 ph/3 w

300 W (1 A) or 1500 W (5 A) for 3 ph/4 w

**PF:** (accur.±0.5 %)

**Frequency:** (accur.±0.1 %) of span

**Energy:** (accur.±1 %)

**Harmonic:** (accur.±1 %) of span

**Analog output:** Accuracy of assigned measurand or ±0.2 %, whichever is greater.

**Response time:** ≤ 2 sec. (0 - 99 %),

≤ 3 sec. for frequency and harmonic contents

**Sampling time:**

**Harmonic contents and frequency:** ≤ 1.1 sec.

**Other:** ≤ 600 msec.

**Insulation resistance:** ≥ 100 MΩ with 500 V DC

**Dielectric strength:** 2000 V AC @ 1 minute

(voltage input to current input to discrete input to network)



## MOUNTING REQUIREMENTS

### ■ PANEL CUTOUT unit: mm (inch)

#### • USING MOUNTING SCREWS

Remove the mounting brackets.

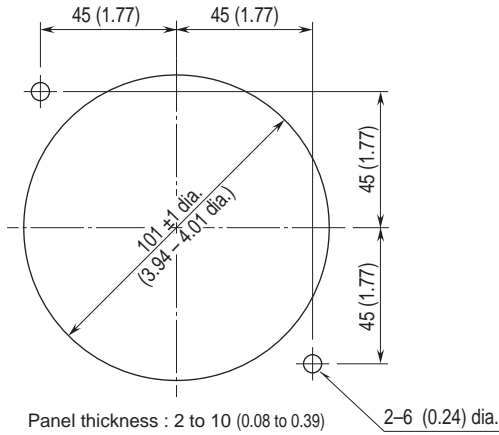

#### • USING MOUNTING BRACKETS

Remove the mounting screws.

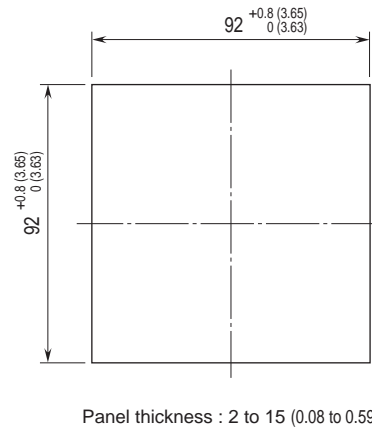

## EXTERNAL VIEW

### ■ FRONT VIEW

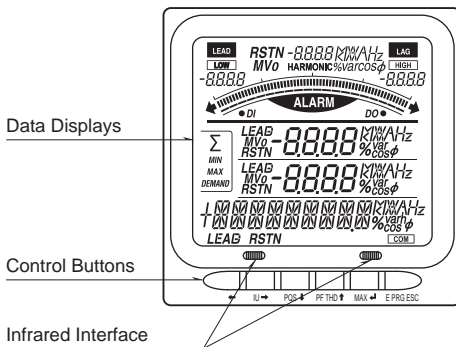

### ■ REAR VIEW

#### • 54U-1

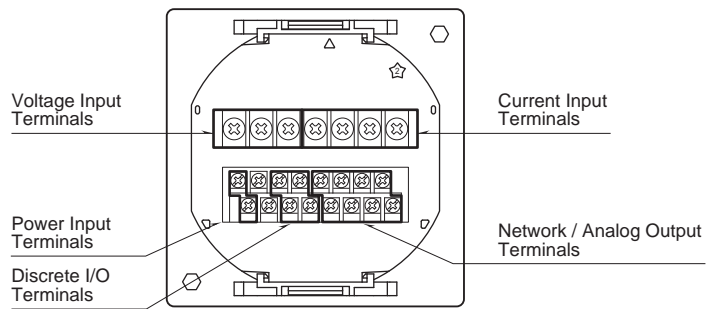

#### • 54U-2

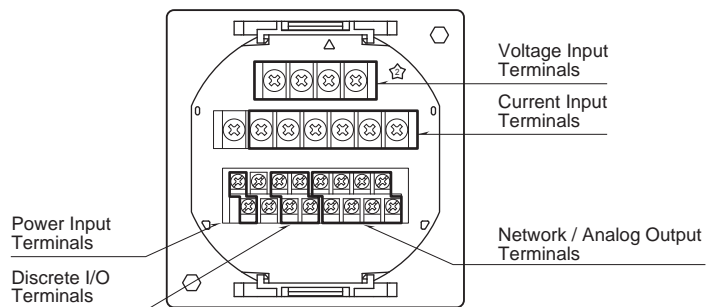

## TERMINAL CONNECTIONS

### ■ 54U-1

#### • Analog Output

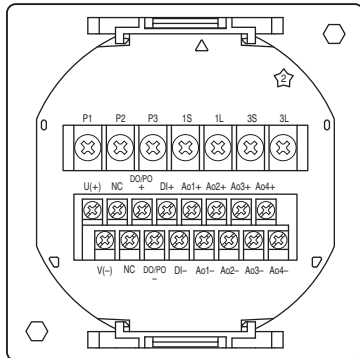

#### • Network Interface

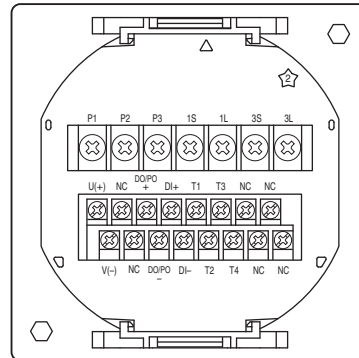

System / Application	Terminal
Single-phase / 2-wire	
Three-phase / 3-wire, balanced load	

System / Application	Terminal
Single-phase / 3-wire	
Three-phase / 3-wire, unbalanced load (2CT)	

## ■ 54U-2

### • Analog Output

### • Network Interface

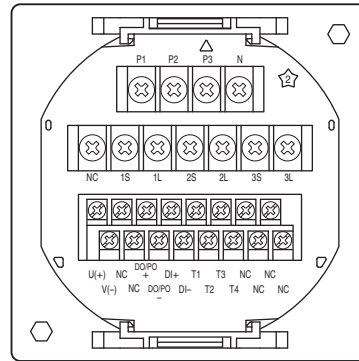
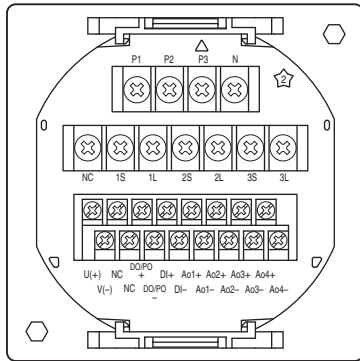

System / Application	Terminal	System / Application	Terminal
Single-phase / 2-wire		Single-phase / 3-wire  Three-phase / 3-wire, unbalanced load (2CT)	
Three-phase / 3-wire, balanced load		Three-phase / 4-wire, balanced load	
Three-phase / 3-wire, unbalanced load (3CT)		Three-phase / 4-wire, unbalanced load	



## EXTERNAL INTERFACE CODE: 1

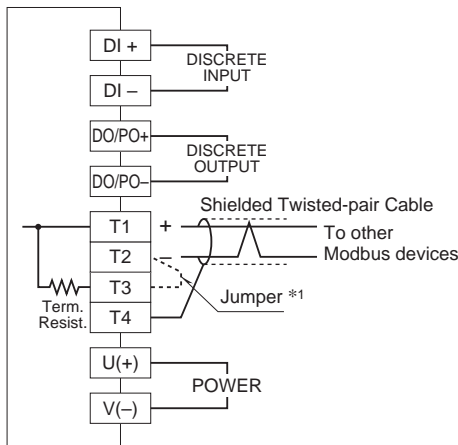

## EXTERNAL INTERFACE CODE: 4

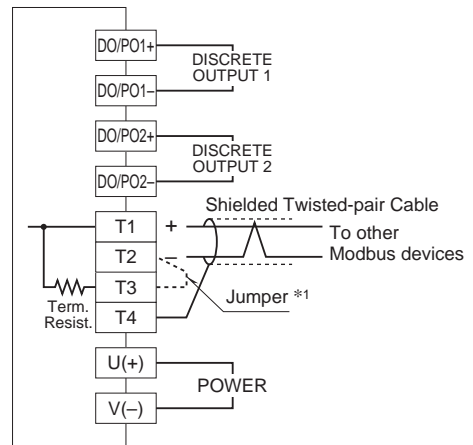

## EXTERNAL INTERFACE CODE: 2, 3

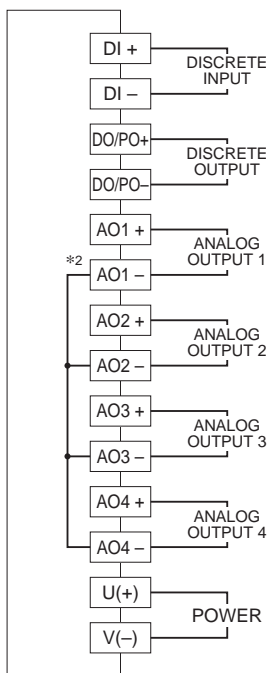

## EXTERNAL INTERFACE CODE: 5, 6

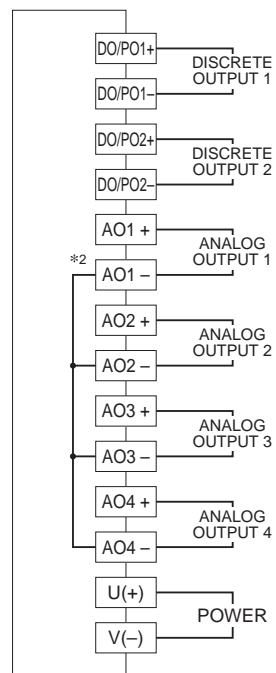

### Discrete Input Connection E.g.

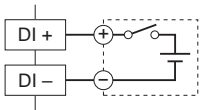

### Discrete Output Connection E.g.

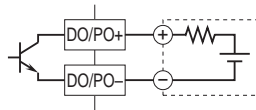

\*1. When the device is located at the end of a transmission line via twisted-pair cable, (when there is no cross-wiring), close across the terminal T2 – T3 with a leadwire.

When the device is not at the end, no shortcircuit wire is required.

\*2. For 'External interface' code 7, 8, 9 and A, the analog outputs are isolated between each other.

## MODBUS WIRING CONNECTION

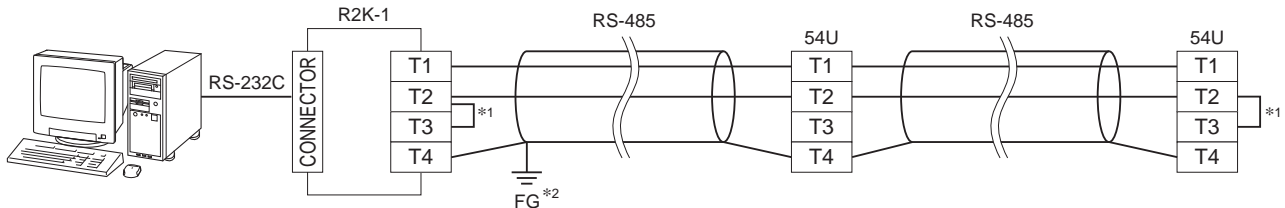

\*1. Internal terminating resistor is used when the device is at the end of a transmission line.

\*2. Install shield cables to all sections and ground them at single point.





**DIMENSIONS unit: mm (inch)**

**CONFIGURATION CODE 1**

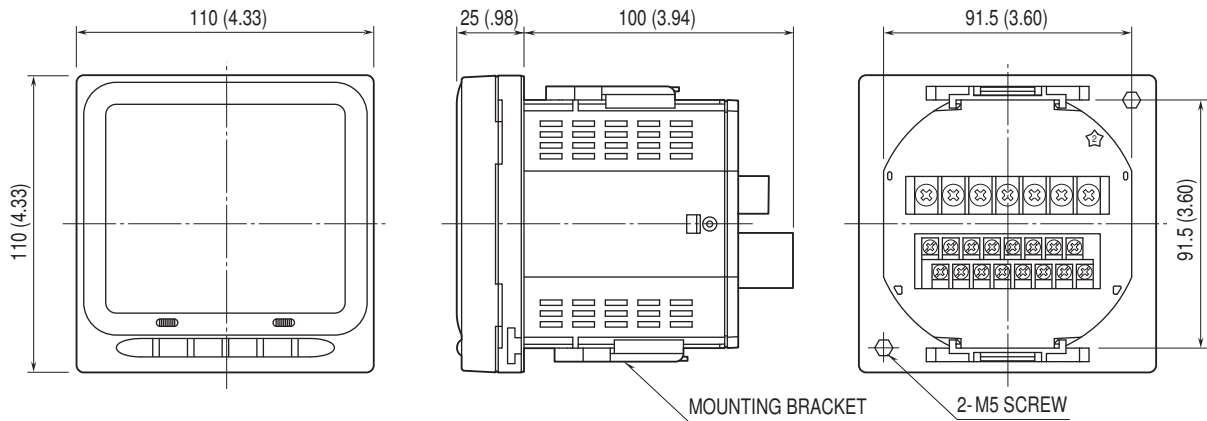

**CONFIGURATION CODE 2**

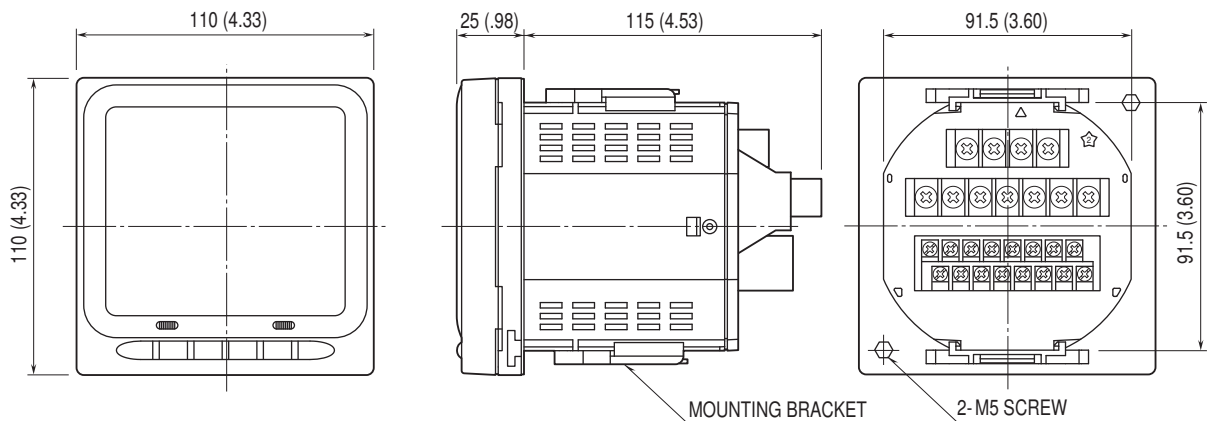



**SYSTEM CONFIGURATION EXAMPLES**

■ RS-485 / RS-232-C

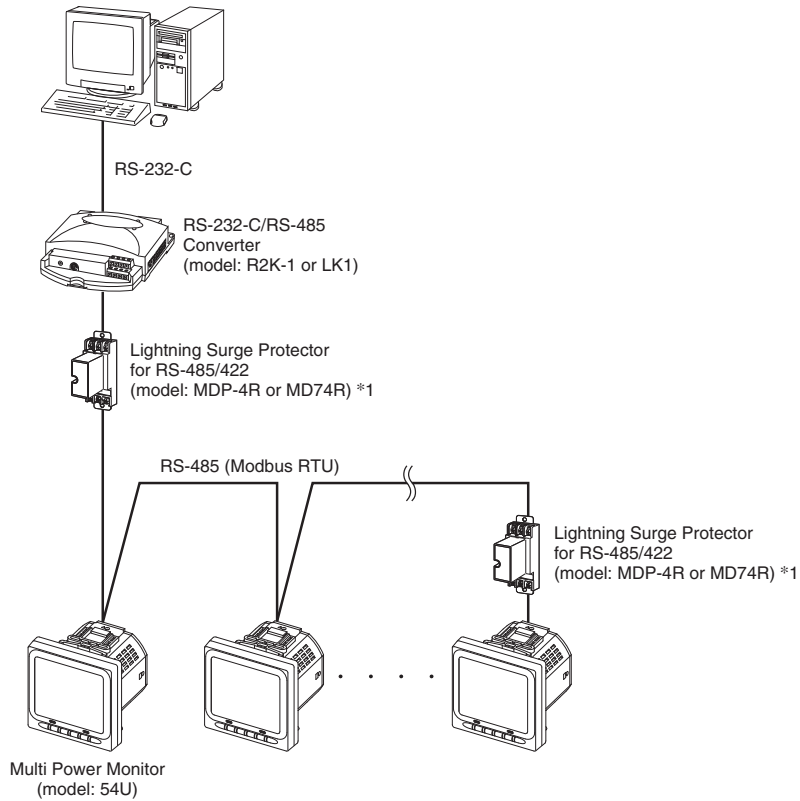

■ RS-485 / ETHERNET

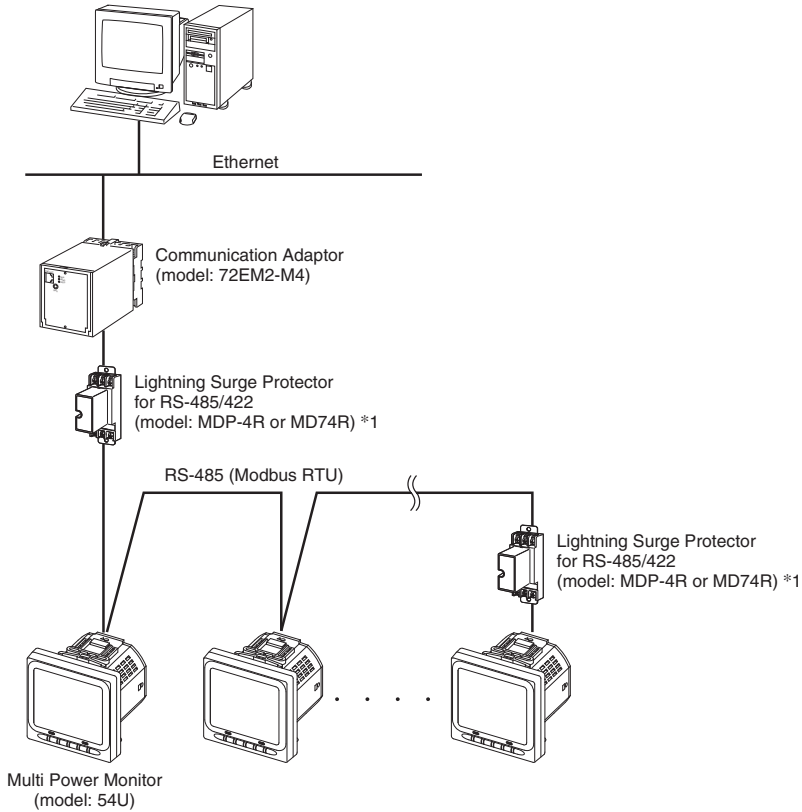

\*1. Insert lightning surge protectors recommended in this example if necessary.





Specifications are subject to change without notice.



**幸託有限公司**  
XIN TOP CORPORATION

TEL : (02)2598-1199  
FAX : (02)2596-2331

E-mail : [info@xintop.com](mailto:info@xintop.com)  
Website : [www.xintop.com](http://www.xintop.com)