

Power Transducer Series

MULTI POWER MONITOR

(4 digital displays)

Functions & Features

- Measures simultaneously several variables of a heavy-current power system: current, voltage, active, reactive and apparent power, active and reactive energy, power factor, frequency, etc.
- All measured values, counter values, display mode, setting data are stored in the non-volatile memory at the power off
- Conversion factors, system configuration, interval times are programmable using the front keys
- Open collector output for alarm or energy count

Typical Applications

- Multi-functional power monitor incorporated in an electric device: saves space, wiring works, and cost

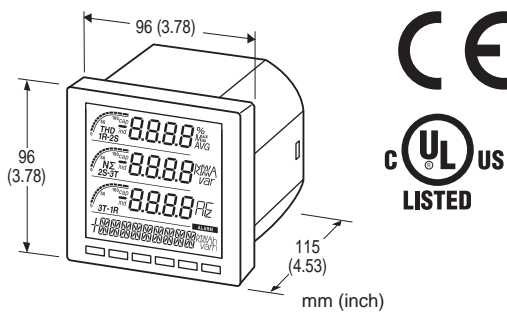

MODEL: 53U-1[1][2][3]-[4][5]

ORDERING INFORMATION

- Code number: 53U-1[1][2][3]-[4][5]
- Specify a code from below for each [1] through [5].
(e.g. 53U-1211-M2/H/Q)
- Specify the specification for option code /Q
(e.g. /SET)

CONFIGURATION

- 1: Single-phase / 2-wire and 3-wire,
3-phase / 3-wire and 4-wire

[1] INPUT

- 1: 480 V / 1 A AC
2: 480 V / 5 A AC

[2] CONTACT INPUT

- 0: None
('External Interface' codes 1, 4 and 5 Not selectable.)
1: 24 V DC
('External Interface' codes 2, 3, 6, 7, 8 and 9 Not selectable.)
2: 110 V DC
('External Interface' codes 2, 3, 6, 7, 8 and 9 Not selectable.)

[3] EXTERNAL INTERFACE

- 1: Modbus, Do x 1, Di x 1
2: 4 - 20 mA DC x 4
3: 1 - 5 V DC x 4
4: 4 - 20 mA DC x 2, Do x 1, Di x 1
5: 1 - 5 V DC x 2, Do x 1, Di x 1
6: 4 - 20 mA DC x 2, Do x 2
7: 1 - 5 V DC x 2, Do x 2
8: Modbus, Do x 3
9: Do x 4

[4] AUXILIARY POWER SUPPLY

- AD4: universal (Option /UL not selectable.)
100 - 240 V AC (Operational range 85 - 264 V, 47 - 66 Hz) /
110 - 240 V DC (Operational range 99 - 264 V,
ripple 10 %p-p max)
M2: 100 - 240 V AC (Operational voltage range 85 - 264 V,
47 - 66 Hz)

[5] OPTIONS (multiple selections)

Performance

- blank: Standard
/H: High accuracy (voltage/current: $\pm 0.2\%$, energy: $\pm 0.5\%$)

Standards & Approvals

- blank: CE marking
/UL: UL approval, CE marking

Other Options

- blank: none
/Q: Option other than the above (specify the specification)
(UL not available)

SPECIFICATIONS OF OPTION: Q

EX-FACTORY SETTING

- /SET: Preset according to the Ordering Information Sheet
(No. ESU-6485)

RELATED PRODUCTS

- PC configurator software (model: PMCFG)
- PC Recorder Light software for the 53U (model: MSR128LUX) Software downloadable at M-System's web. Software downloadable at M-System's web site.
A dedicated cable is required to connect the module to the



PC. Please refer to the internet software download site or the users manual for the PC configurator for applicable cable types.

GENERAL SPECIFICATIONS

Construction: 96-mm square (1/4 DIN size) panel flush mounted

Degree of protection

Front panel: IP 50

Terminal block, housing: IP 30

Connection

Voltage input: Connector type terminal block (applicable wire size ≤ 2.5 dia, $0.5 - 3.5$ mm²)

Current input: Screw terminal block (applicable wire size ≤ 2.4 dia, $0.5 - 3.5$ mm²)

Output, power: Connector type terminal block (applicable wire size ≤ 2.4 dia, $0.5 - 2.5$ mm²)

Configuration: Single phase/2-wire and 3-wire, 3-phase/3-wire balanced/unbalanced load, 3-phase/4-wire balanced/unbalanced load

Housing material: Flame-resistant resin (gray)

Isolation: Voltage input to current input to contact input to network interface or configurator jack or analog output to contact output (between each contact output except for External Interface code 8) to power

• **Measured variables**

Voltage: 1 - N, 2 - N, 3 - N, 1 - 2, 2 - 3, 3 - 1

Current: 1, 2, 3, N

Average current: 1, 2, 3

Active / reactive / apparent power: 1, 2, 3, Σ

Power factor: 1, 2, 3, Σ

Frequency

Phase angle between voltages: 1 - 2, 2 - 3, 3 - 1

Active energy incoming / outgoing: Σ

Reactive energy inductive / capacitive: Σ

Apparent energy: Σ

Active / reactive / apparent power intervals (demand)

Other demands

Harmonic contents: 2nd to 31st

Max. and min. values

■ **DISPLAY:** LCD with LED backlight (LED OFF timer available)

Signed: 4 digits, 3 lines

Energy: 9 digits, 1 line

Bargraph: 3 points

INPUT SPECIFICATIONS

Frequency: 50 / 60 Hz (45 - 65 Hz)

• **Voltage Input**

Rated voltage

Line-to-line (delta voltage): 480 V

Line-neutral (phase voltage): 277 V (single-phase / 2-wire and 3-wire)

Consumption VA: $\leq U_{LN}^2 / 300$ k Ω / phase

Overload capacity: 200 % of rating for 10 sec., 120% continuous

Selectable primary voltage range: 50 - 400 000 V

• **Current Input**

Rated current: 1 A or 5 A

Consumption VA: $\leq I^2 \cdot 0.01$ Ω / phase

Overload capacity: 4000 % of rating for 1 sec., 2000% for 4 sec., 120% continuous

Selectable primary current range: 1 - 20 000 A

Operational range

Voltage, current, apparent power: ≤ 120 % of the rating

Active/reactive power: $\leq \pm 120$ % of the rating

Frequency: 45 - 65 Hz

Power factor: $\leq \pm 1$

■ **Contact Input:** 24 V DC or 110 V DC

(input resistance 6 k Ω)

Detecting voltage: External 24 V DC ± 10 % or 110 V DC ± 10 %

ON current: ≥ 1 mA (≤ 24 k Ω @ 24 V, ≤ 110 k Ω @ 110 V)

OFF current: ≤ 0.1 mA (≥ 240 k Ω @ 24 V, ≥ 1.1 M Ω @ 110 V)

Detecting time: 10 - 1000 msec.

The status can be monitored on the Modbus; usable to reset energy count or to update average (demand) value.

OUTPUT SPECIFICATIONS

■ **Network Interface**

Communication: Half-duplex, asynchronous, no procedure

Interface: Conforms to EIA RS-485

Max. transmission distance: 500 meters

Baud rate: 1.2 - 38.4 kbps

Max. number of nodes: 31 (except the master)

Protocol: Modbus RTU

Node address: 1 - 247 (factory default setting: 1)

Parity: none, even or odd (factory default setting: odd)

Stop bit: 1 or 2 (factory default setting: 1)

Media: Shielded twisted-pair cable (CPEV-S 0.9 dia.)

■ **DC Current:** 4 - 20 mA DC

Load resistance: ≤ 270 Ω

Measurands converted into analog output: Voltage, Current, Active / reactive / apparent power, Power factor, Frequency, Harmonic contents

■ **DC Voltage:** 1 - 5 V DC

Load resistance: ≥ 5000 Ω

Measurands converted into analog output: Voltage, Current, Active / reactive / apparent power, Power factor, Frequency, Harmonic contents

■ **Open Collector**



Programmable for either alarm or energy count.

Max. rated load: 130 V DC @50 mA

Continuous rated load: 130 V DC @30 mA

Saturation voltage: 1.5 V DC

Measurands applicable to alarm: Voltage, current, current intervals, neutral current, frequency, energy, energy intervals

(ON delay, deadband and other parameters are selectable)

Measurands applicable to count: Energy;

Pulse rate selectable within

0.1 - 10 000.0 kWh/p, kvarh/p, kVAh/p

output to power)

2500 V AC @1 minute

(voltage input to current input to contact input to contact output to network interface or configurator jack or analog output)

2000 V AC @1 minute

(between each contact output except for External Interface code 8)

2000 V AC @1 minute (circuits to housing)

STANDARDS & APPROVALS

CE conformity:

EMC Directive (2004/108/EC)

EMI EN 61000-6-4: 2007

EMS EN 61000-6-2: 2005

Low Voltage Directive (2006/95/EC)

EN 61010-1: 2001

Measurement Category III (input)

Installation Category II (power)

Pollution Degree 2

Input to power: Reinforced insulation (550 V)

Output to power: Reinforced insulation (300 V)

Input to output: Basic insulation (550 V)

Approval:

UL/C-UL general safety requirements

(UL 61010-1:2005, CAN/CSA-C22.2 No.61010-1:2004)

IEC standard:

IEC 62053-22: 2003 class 0.5s

IEC 62053-23: 2003 class 2

(IEC standards are applicable with Option /H only)

INSTALLATION

Power consumption

•AC: < 8 VA

•DC: < 4 W

Operating temperature: -10 to +55°C (14 to 131°F)

Storage temperature: -20 to +80°C (-4 to +176°F)

Operating humidity: 90 % RH max. (non-condensing)

Mounting: Panel flush mounting

Weight: 300 g (0.66 lb)

PERFORMANCE

Accuracy (at 23°C ±10°C or 73.4°F ±18°F, 45 - 65 Hz)

Voltage: ±0.3 % (±0.2 % for Option /H)*

Current: ±0.3 % (±0.2 % for Option /H)*

Power: ±0.5 %*

Power factor: ±0.5 %

Frequency: ±0.1 %*

Energy: ±1 % (±0.5 % for Option /H)

Harmonic contents: ±1 %*

Analog output: Accuracy of assigned measurand or ±0.2 %, whichever is greater.

* In percentage of the spans: 480 V for voltage, 1 A or 5 A for current, 4155 W (5 A) or 831 W (1 A) for active power. The described accuracy levels are ensured at the input 1 % or more for phase 2 current with 3-phase/3-wire unbalanced load, for neutral current with 3-phase/4-wire unbalanced load, and neutral current with 1-phase/3-wire.

Response time: ≤ 2 sec. (0 - 99 %),

≤ 3 sec. for frequency and harmonic contents

Sampling time:

Harmonic contents and frequency: ≤ 1.1 sec.

Other: ≤ 600 msec.

Insulation resistance: ≥ 100 MΩ with 500 V DC

Dielectric strength:

4000 V AC @1 minute

(voltage input or current input or contact input or contact output or network interface or configurator jack or analog

MOUNTING REQUIREMENTS mm (inch)

■ PANEL CUTOUT unit: mm (inch)

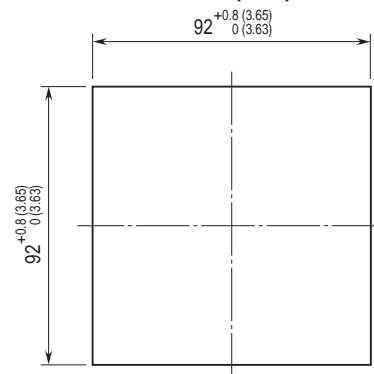

Panel thickness : 2 to 15 mm (0.08 to 0.59 inch)



幸託有限公司

XIN TOP CORPORATION

TEL : (02)2598-1199

FAX : (02)2596-2331

E-mail : info@xintop.com

Website : www.xintop.com

EXTERNAL VIEW

■ FRONT VIEW

■ REAR VIEW

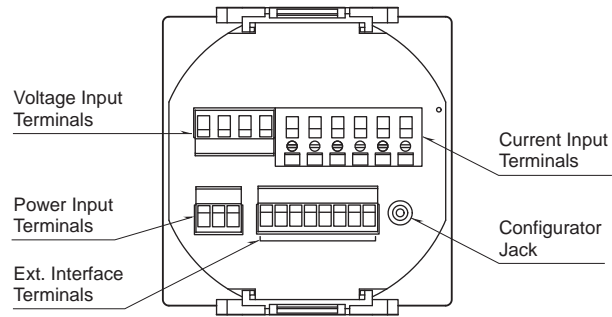
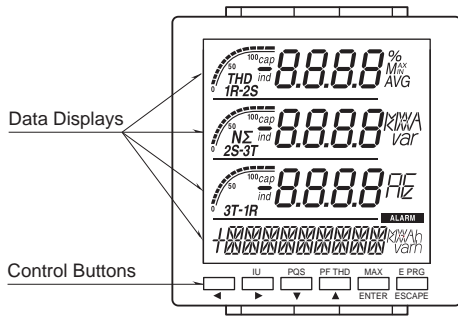

TERMINAL CONNECTIONS

For UL approved model, L and N are marked, instead of U(+) and V(-).

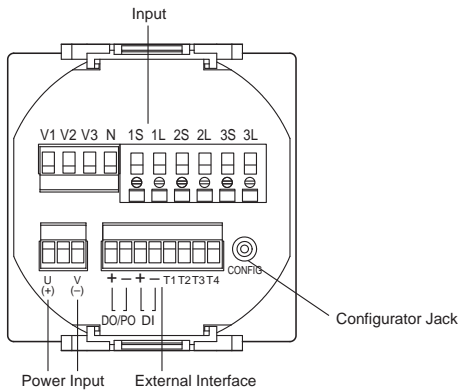

System / Application	Terminal
Three phase / 3-wire, unbalanced load	
Single phase / 2-wire	
Three phase / 4-wire, balanced load	
Three phase / 3-wire, balanced load	
Three phase / 4-wire, unbalanced load	
Single phase / 3-wire	



EXTERNAL INTERFACE CODE: 1

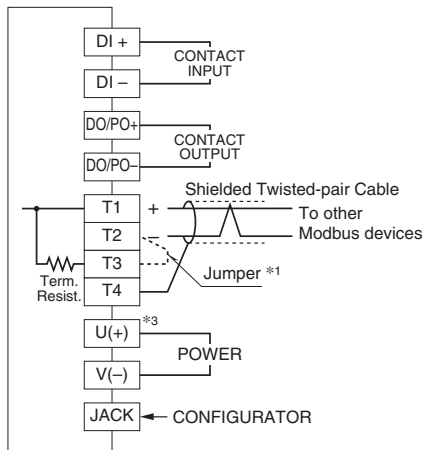

EXTERNAL INTERFACE CODE: 2, 3

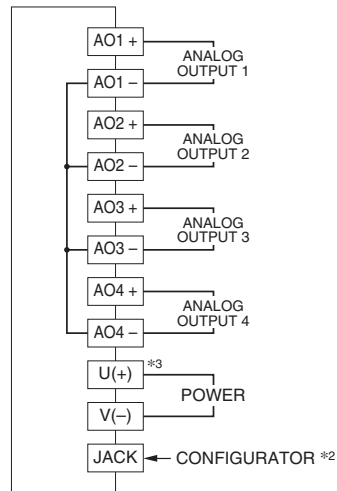

EXTERNAL INTERFACE CODE: 4, 5

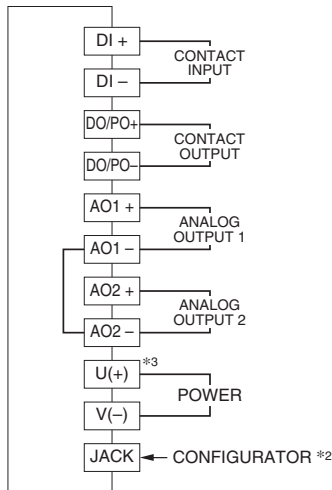

EXTERNAL INTERFACE CODE: 6, 7

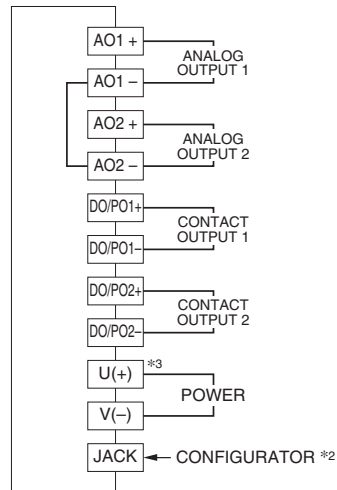

EXTERNAL INTERFACE CODE: 8

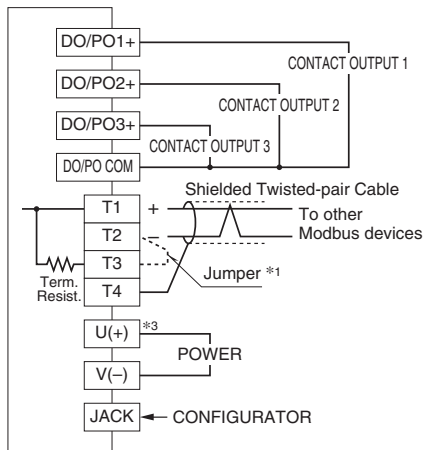

EXTERNAL INTERFACE CODE: 9

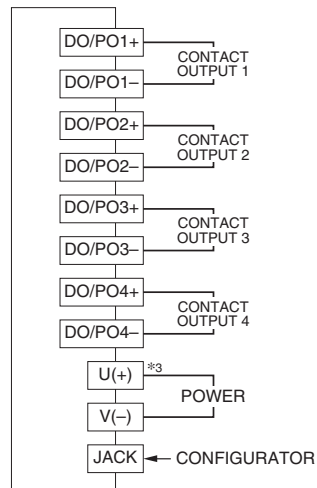

• Contact Input Connection E.g. • Contact Output Connection E.g.

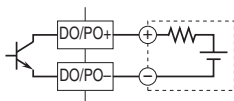
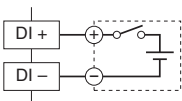

*1. When the device is located at the end of a transmission line via twisted-pair cable, (when there is no cross-wiring), close across the terminal T2 – T3 with a leadwire.

When the device is not at the end, no shortcircuit wire is required.
*2. Analog output may momentarily fluctuate while the configurator cable is left connected.

*3. For UL approved model, L and N are marked, instead of U(+) and V(-).

MODBUS WIRING CONNECTION

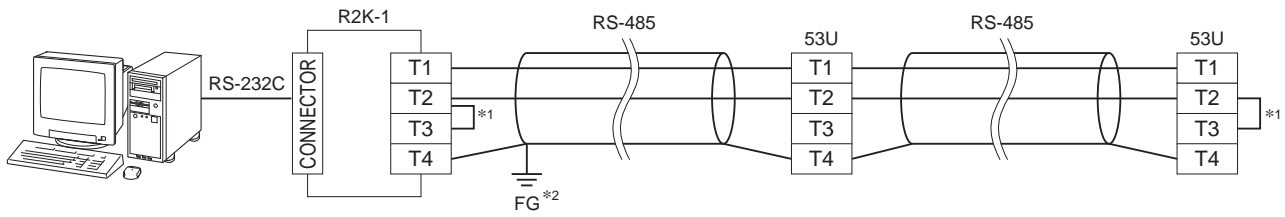

- *1. Internal terminating resistor is used when the device is at the end of a transmission line.
- *2. Install shield cables to all sections and ground them at single point.

DIMENSIONS unit: mm (inch)

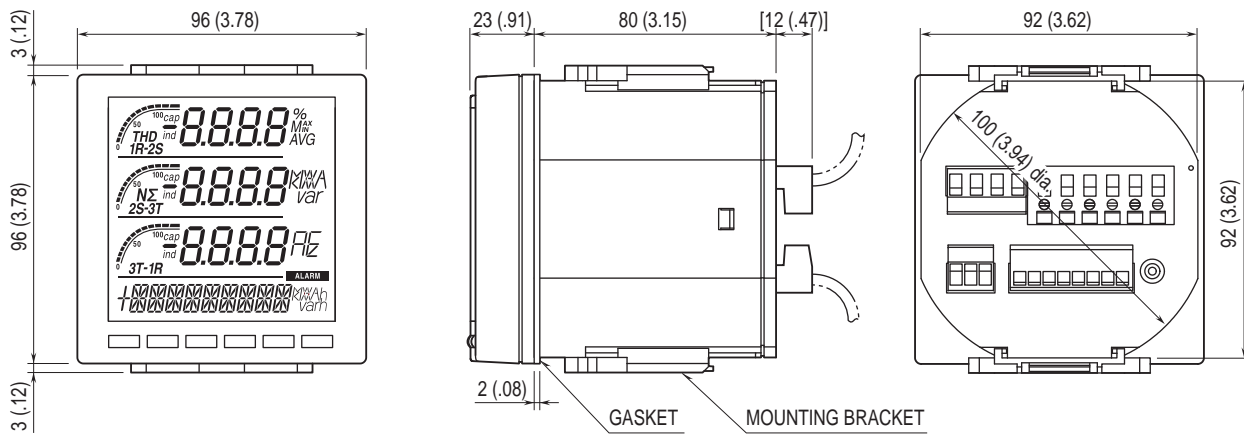

SYSTEM CONFIGURATION EXAMPLES

■ RS-485 / RS-232C

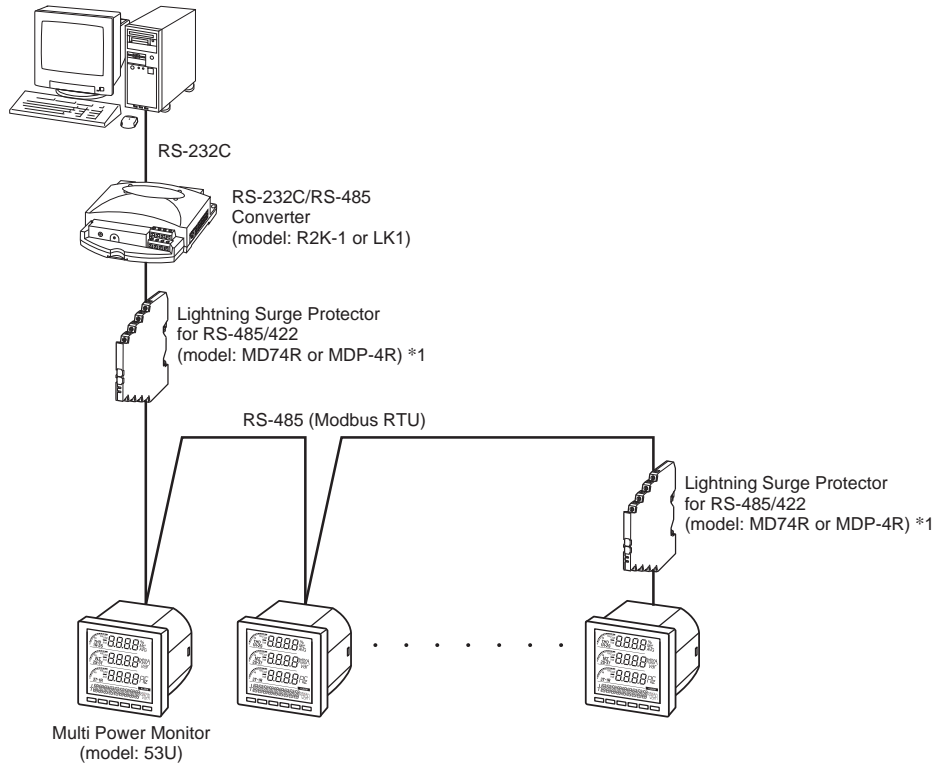

■ RS-485 / ETHERNET

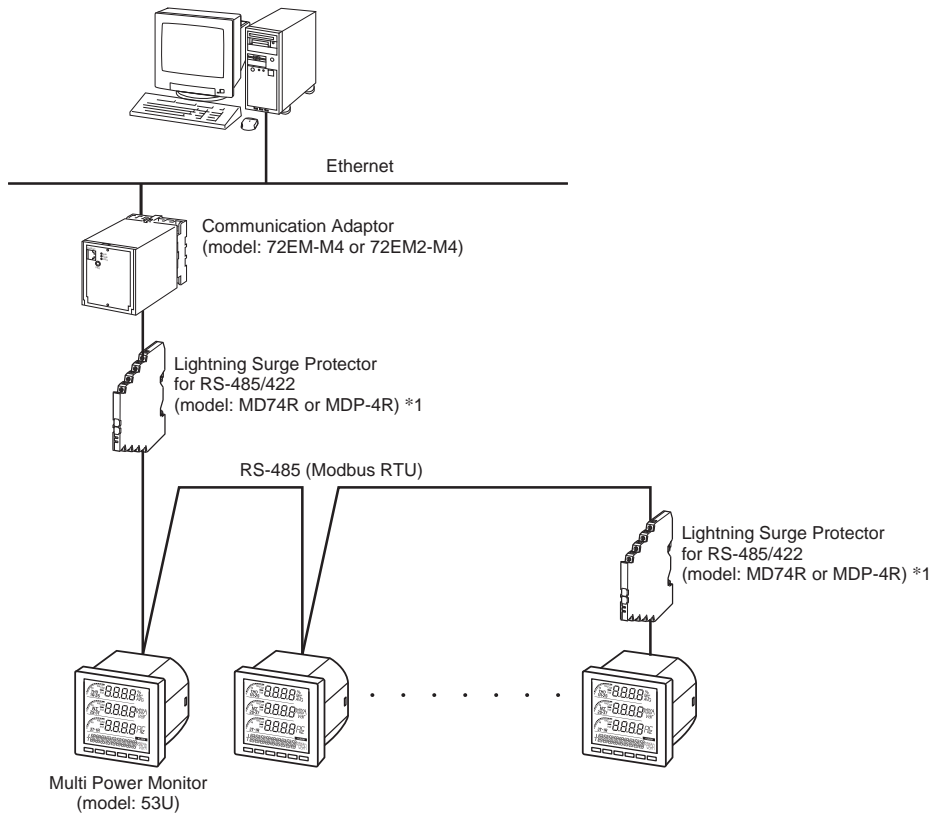

*1. Insert lightning surge protectors recommended in this example if necessary.





Specifications are subject to change without notice.



幸託有限公司
XIN TOP CORPORATION

TEL : (02)2598-1199
FAX : (02)2596-2331

E-mail : info@xintop.com
Website : www.xintop.com