



PTB110 Barometer

For industrial use



Features

- Vaisala BAROCAP® sensor
- Several pressure ranges
- Accuracy ± 0.3 hPa at $+20$ °C
- Long-term stability
- On/Off control with external trigger
- Output voltage 0 ... 2.5 or 0 ... 5 VDC
- Current consumption less than 4 mA
- Mountable on 35 mm wide DIN rail
- Traceable calibration (certificate included)

Vaisala BAROCAP® Barometer PTB110 is designed both for accurate barometric pressure measurements at room temperature and for general environmental pressure monitoring over a wide temperature range.

Vaisala BAROCAP Technology

PTB110 uses the Vaisala BAROCAP sensor, a silicon capacitive absolute pressure sensor developed by Vaisala for barometric pressure measurement applications. The sensor combines the outstanding elasticity characteristics and mechanical stability of single-crystal silicon with the proven capacitive detection principle.

Applications

PTB110 is suitable for a variety of applications, such as environmental pressure monitoring, data buoys, laser interferometers, and agriculture and hydrology. The compact PTB110 is ideal for data logger applications as it has low power consumption. The external On/Off control is practical when electricity supply is limited.

Accuracy and Stability

The excellent long-term stability of the barometer minimizes or even removes the need for field adjustment in many applications.



幸託有限公司
XIN TOP CORPORATION

TEL : (02)2598-1199
FAX : (02)2596-2331

E-mail : info@xintop.com
Website : www.xintop.com

Technical Data

Measurement performance

Pressure range (1 hPa= 1 mbar)	500 ... 1100 hPa 600 ... 1100 hPa 800 ... 1100 hPa 800 ... 1060 hPa 600 ... 1060 hPa
Resolution	0.1 hPa
Load resistance	10 000 Ω minimum
Load capacitance	47 nF maximum
Settling time to full accuracy after startup	1 s
Response time to full accuracy after a pressure step	500 ms
Acceleration sensitivity	Negligible
Accuracy	
Linearity ¹⁾	±0.25 hPa
Hysteresis ¹⁾	±0.03 hPa
Repeatability ¹⁾	±0.03 hPa
Pressure calibration uncertainty ²⁾	±0.15 hPa
Voltage calibration uncertainty	±0.7 mV
Frequency calibration uncertainty	±0.3 Hz
Accuracy at +20 °C (+68 °F) ³⁾	±0.3 hPa
Total accuracy at	
+15 ... +25 °C (+59 ... +77 °F)	±0.3 hPa
0 ... +40 °C (+32 ... +104 °F)	±0.6 hPa
-20 ... +45 °C (-4 ... +113 °F)	±1.0 hPa
-40 ... +60 °C (-40 ... +140 °F)	±1.5 hPa
Long-term stability	±0.1 hPa / year

- 1) Defined as ±2 standard deviation limits of end-point non-linearity, hysteresis error, or repeatability error.
 2) Defined as ±2 standard deviation limits of inaccuracy of the working standard including traceability to international standards.
 3) Defined as the root sum of the squares (RSS) of end-point non-linearity, hysteresis error, repeatability error, and calibration uncertainty at room temperature.

Operating environment

Operating temperature	-40 ... +60 °C (-40 ... +140 °F)
Storage temperature	-40 ... +60 °C (-40 ... +140 °F)
Operating humidity	Non-condensing
IP rating	IP32
Electromagnetic compatibility (EMC)	EN 61326-1, industrial environment

Mechanical specifications

Dimensions (H × W × D)	97.3 × 68.4 × 28.1 mm (3.83 × 2.69 × 1.10 in)
Weight	90 g (3.2 oz)
Materials	
Housing cover	Plastic ABS/PC blend
Mounting plate	Aluminum

Inputs and outputs

Supply voltage	10 ... 30 V DC
Supply voltage control	With TTL-level (Transistor-Transistor-Logic) trigger
Supply voltage sensitivity	Negligible
Average power consumption	0.10 W at 12 V
Output voltage	0 ... 2.5 V DC 0 ... 5 V DC
Output frequency	500 ... 1100 Hz
Pressure connector	M5 (10 ... 32) internal thread
Pressure fitting	Barbed fitting for 1/8 in
Minimum pressure limit	0 hPa abs
Maximum pressure limit	2000 hPa abs
Electrical connector	A removable connector for 5 wires (AWG 28 ... 16)
Terminals	Pin 1: External triggering Pin 2: Signal ground Pin 3: Supply ground Pin 4: Supply voltage Pin 5: Voltage/Frequency output

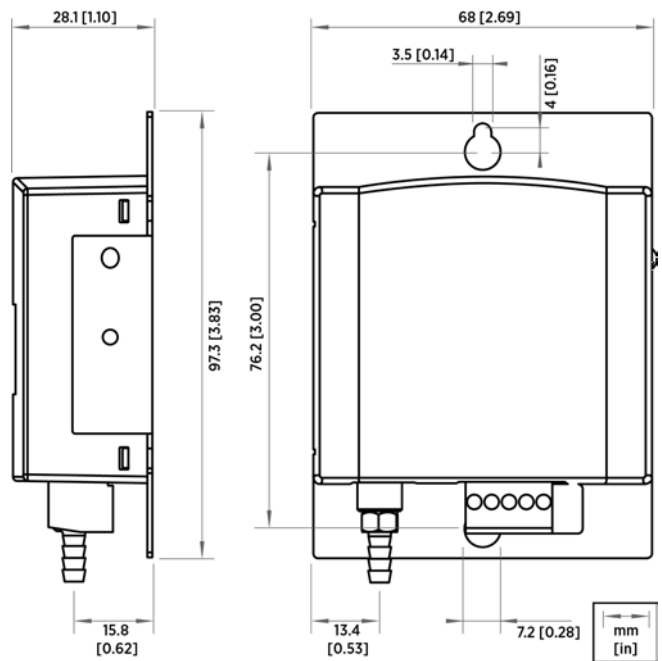

Dimensions



幸託有限公司
XIN TOP CORPORATION

TEL : (02)2598-1199
FAX : (02)2596-2331

E-mail : info@xintop.com
Website : www.xintop.com