



# HMDW80 Series Humidity and Temperature Transmitters

For building automation applications



## Features

- Reliable transmitters for basic HVAC humidity measurements
- $\pm 3.0$  %RH accuracy
- Full 0 ... 100 %RH measurement range
- Optimized for easy installation and low maintenance
- User exchangeable INTERCAP® sensor for easy field replacement
- UL-V0 flammability rating
- Output parameters: relative humidity and temperature with optional dew point temperature, wet bulb temperature and enthalpy parameters

Vaisala HMDW80 Series INTERCAP® Humidity and Temperature Transmitters measure relative humidity and temperature in various building automation applications. HMDW80 series transmitters combine easy installation and reliable operation with a low requirement for maintenance.

## Typical installation locations

- Ventilation ducts
- Walls
- Wash-down areas
- Outdoor locations

The versatile HMDW80 series includes transmitters for wall and duct mounting, IP65-classified transmitters for humid areas, and transmitters with a radiation shield for outdoor use. It also includes temperature-only transmitters and transmitters with an optional display.

Calculated humidity parameters – dew point temperature, wet bulb temperature, and enthalpy – are also available.

## Easy installation

HMDW80 series transmitters are optimized for easy installation. There are no loose parts, screws are retained in the enclosure, all connectors are clearly labeled, and the connectors are within easy reach.

The duct mount transmitters are well suited to a variety of duct sizes, the outdoor transmitters can be mounted directly onto a wall or pole without any

extra accessories, and the wall mount transmitters can be installed without the need to make holes in the transmitter enclosure.

## Reliable operation

HMDW80 series transmitters require minimal maintenance thanks to their excellent sensor stability and high-quality materials. If necessary, the INTERCAP® sensor can be easily exchanged in the field with minimum downtime.



**幸託有限公司**  
XIN TOP CORPORATION

TEL : (02)2598-1199

FAX : (02)2596-2331

E-mail : [info@xintop.com](mailto:info@xintop.com)

Website : [www.xintop.com](http://www.xintop.com)

Model number	Type	Output	Special features	IP rating
TMW82	Wall-mount, T-only	2-wire, current output		IP30
HMW82	Wall-mount, RH+T	2-wire, current output		IP30
HMW82P100	Wall mount, RH+T	2-wire, current output	Additional Pt100 sensor	IP30
HMW83	Wall-mount, RH+T	3-wire, voltage output		IP30
TMW88	Wall-mount, T-only	2-wire, current output		IP65
HMW88	Wall-mount, RH+T	2-wire, current output	Calculated parameters <sup>1)</sup>	IP65
HMW88D	Wall-mount, RH+T	2-wire, current output	Display, calculated parameters <sup>1)</sup>	IP65
HMW89	Wall-mount, RH+T	3-wire, voltage output	Calculated parameters <sup>1)</sup>	IP65
HMW89D	Wall-mount, RH+T	3-wire, voltage output	Display, calculated parameters <sup>1)</sup>	IP65
TMD82	Duct-mount, T-only	2-wire, current output		IP65
HMD82	Duct-mount, RH+T	2-wire, current output	Calculated parameters <sup>1)</sup>	IP65
HMD82D	Duct-mount, RH+T	2-wire, current output	Display, calculated parameters <sup>1)</sup>	IP65
HMD83	Duct-mount, RH+T	3-wire, voltage output	Calculated parameters <sup>1)</sup>	IP65
HMD83D	Duct-mount, RH+T	3-wire, voltage output	Display, calculated parameters <sup>1)</sup>	IP65
HMS82	Outdoor, RH+T	2-wire, current output	Radiation shield, calculated parameters <sup>1)</sup>	IP65
HMS82C	Outdoor, RH+T	2-wire, current output	HMS82 with NPT ½" conduit fitting <sup>1)</sup>	IP65
HMS83	Outdoor, RH+T	3-wire, voltage output	Radiation shield, calculated parameters <sup>1)</sup>	IP65
HMS83C	Outdoor, RH+T	3-wire, voltage output	HMS83 with NPT ½" conduit fitting <sup>1)</sup>	IP65
TMS82	Outdoor, T-only	2-wire, current output	Radiation shield	IP65

1) Output parameters for humidity: relative humidity, dew point temperature, wet bulb temperature, and enthalpy.



**幸託有限公司**  
XIN TOP CORPORATION

TEL : (02)2598-1199  
FAX : (02)2596-2331

E-mail : [info@xintop.com](mailto:info@xintop.com)  
Website : [www.xintop.com](http://www.xintop.com)

# Dimensions

**HMW82/83 RH+T and TMW82 T-only transmitters for wall-mounting**

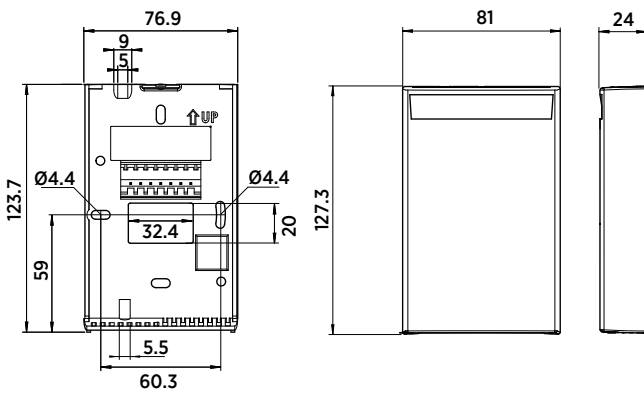

**HMS82/83 RH+T and TMS82 T-only transmitters for outdoor measurements**

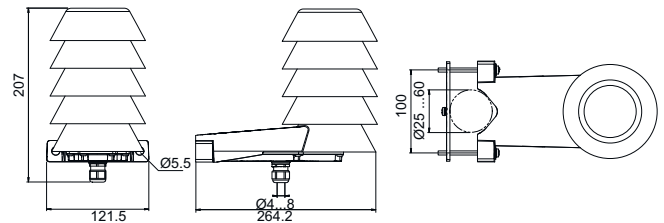

**HMW88/89(D) RH+T and TMW88 T-only transmitters for measurements in wet areas**

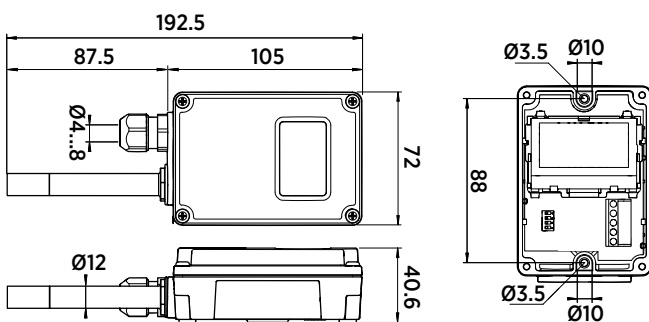

**HMD82/83(D) RH+T and TMD82 T-only transmitters for ducts**

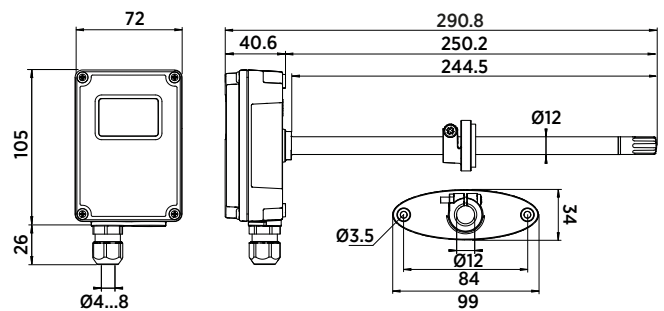

# Technical data

## Measurement performance, models HMW82/83 and TMW82

Relative humidity	
Measurement range	0 ... 100 %RH
Accuracy in temperature range +10 ... +30 °C (+50 ... +86 °F)	±3 %RH (0 ... 70 %RH) ±5 %RH (70 ... 100 %RH)
Accuracy in temperature range -5 ... +10 °C, +30 ... +55 °C (+23 ... +50 °F, +86 ... +131 °F)	±7 %RH (0 ... 100 %RH)
Stability in typical HVAC applications	±2 %RH over 2 years
Humidity sensor	Vaisala INTERCAP®
Temperature	
Measurement range	-5 ... +55 °C (+23 ... +131 °F)
Accuracy at +10 ... +30 °C (+50 °F ... +86 °F)	±0.5 °C (±0.9 °F)
Accuracy at -5 ... +10 °C, +30 ... +55 °C (+23 ... +50 °F, +86 ... +131 °F)	±1.0 °C (±1.8 °F)
Temperature sensor	Digital temperature sensor
Temperature sensor HMW82P100	Pt100 Class F 0.1 IEC 60751, 3-wire connection

## Measurement performance, models HMD82/83, TMD82, HMW88/89, TMW88, HMS82/83, and TMS82

Relative humidity	
Measurement range	0 ... 100 %RH
Accuracy in temperature range +10 ... +30 °C (+50 ... +86 °F)	±3 %RH (0 ... 90 %RH) ±5 %RH (90 ... 100 %RH)
Accuracy in temperature range -20 ... +10 °C, +30 ... +60 °C (-4 ... +50 °F, +86 ... +140 °F)	±5 %RH (0 ... 90 %RH) ±7 %RH (90 ... 100 %RH)
Accuracy in temperature range -40 ... -20 °C (-40 ... -4 °F)	±7 %RH (0 ... 100 %RH)
Stability in typical HVAC applications	±2 %RH over 2 years
Humidity sensor	Vaisala INTERCAP®
Temperature	
Measurement range	-40 ... +60 °C (-40 ... +140 °F)
Accuracy at +20 °C (+68 °F)	±0.3 °C (±0.54 °F)
Temperature dependence	±0.01 °C/ °C
Temperature sensor	Pt1000 RTD Class F0.1 IEC 60751
Calculated parameters	
Measurement range for dew point temperature and wet bulb temperature	-40 ... +60 °C (-40 ... +140 °F)
Measurement range for enthalpy	-40 ... 460 kJ/kg (-10 ... +190 BTU/lb)

## Operating environment

Maximum wind/flow speed	30 m/s
Storage temperature	-40 ... +60 °C (-40 ... +140 °F)
EMC compliance	EN61326-1, Industrial Environment
Operating temperature	
HMW82/83 and TMW82	-5 ... +55 °C (+23 ... +131 °F)
HMD82/83, TMD82, HMW88/89, TMW88, HMS82/83, and TMS82	-40 ... +60 °C (-40 ... +140 °F)
HMD82/83D and HMW88/89D	-5 ... +60 °C (+23 ... +140 °F)
Operating humidity	
HMD82/83, TMD82, HMW88/89, TMW88, HMS82/83, and TMS82	0 ... 100 %RH
HMW82/83, TMW82, HMD82/83D and HMW88/89D	0 ... 100 %RH, non-condensing

## Measurement performance, models HMD82/83D and HMW88/89D

Relative humidity	
Measurement range	0 ... 100 %RH
Accuracy in temperature range +10 ... +30 °C (+50 ... +86 °F)	±3 %RH (0 ... 90 %RH) ±5 %RH (90 ... 100 %RH)
Accuracy in temperature range -5 ... +10 °C, +30 ... +60 °C (+23 ... +50 °F, +86 ... +140 °F)	±5 %RH (0 ... 90 %RH) ±7 %RH (90 ... 100 %RH)
Stability in typical HVAC applications	±2 %RH over 2 years
Humidity sensor	Vaisala INTERCAP®
Temperature	
Measurement range	(Analog output scaling) -40 ... +60 °C (-40 ... +140 °F)
Accuracy at +20 °C (+68 °F)	±0.3 °C (±0.54 °F)
Temperature dependence	±0.01 °C/ °C
Temperature sensor	Pt1000 RTD Class F0.1 IEC 60751
Calculated parameters	
Measurement range for dew point temperature and wet bulb temperature	-40 ... +60 °C (-40 ... +140 °F)
Measurement range for enthalpy	-40 ... 460 kJ/kg (-10 ... +190 BTU/lb)

## Inputs and outputs

Current output models (2-wire)	
Outputs	4 ... 20 mA, loop powered
Loop resistance	0 ... 600 Ω
Supply voltage	20 ... 28 VDC at 600 Ω load 10 ... 28 VDC at 0 Ω load
Voltage output models (3-wire)	
Outputs	0 ... 10 V
Load resistance	10 kΩ min
Supply voltage	18 ... 35 VDC 24 VAC ±20 % 50/60 Hz

## Mechanical specifications

Max wire size	1.5 mm <sup>2</sup> (AWG 16)
Standard housing color	White (RAL9003)
Housing material	
HMW82/83, TMW82	ABS/PC (UL-V0 approved)
HMW88/89(D), HMD82/83(D), TMW88, TMD82, HMS82/83, TMS82	PC + 10 %GF (UL-V0 approved)



幸託有限公司  
XIN TOP CORPORATION

TEL : (02)2598-1199  
FAX : (02)2596-2331

E-mail : info@xintop.com  
Website : www.xintop.com

## Spare parts and accessories

INTERCAP sensor	15778HM
10 pcs of INTERCAP sensors	INTERCAPSET-10PCS
Conduit fitting + O-ring (M16×1.5 / NPT ½")	210675SP
Conduit fitting + O-ring (M16×1.5 / PG9, RE-MS)	210674SP
Fastening set HMS80	237805
Porous PTFE filter	DRW239993SP
Membrane filter	ASM210856SP
Terminal block, blue	236620SP
HMD80 display lid	ASM210793SP



**幸託有限公司**  
XIN TOP CORPORATION

TEL : (02)2598-1199  
FAX : (02)2596-2331

E-mail : [info@xintop.com](mailto:info@xintop.com)  
Website : [www.xintop.com](http://www.xintop.com)