

## Differential pressure and Pitot tube measurement Measuring connector FDA 602 S1K / S6K



Measuring connector FDA602S1K / S6K

- Pressure measuring connector in compact design for flow measurement with Pitot tubes
- Fitting for connecting hose between Pitot tube and pressure measuring connector
- Pressure measuring connector can be plugged directly onto the measuring instrument.

### Technical data

Overload capacity	Maximum three times final value
Max. common mode pressure	700 mbar
Accuracy differential pressure (zero-point adjusted)	±0.5% of final value in range 0 to positive final value
Nominal temperature	25 °C
Temperature drift	< ±1.5 % of final value
Compensated temp. range	0 to +60 °C

Operating range	-10 to +60 °C, 10 to 90% RH, non-condensing
Dimensions	74 x 20 x 8.8 mm
Hose terminals	Ø 5 mm, 12 mm long
Sensor material	aluminum, nylon, silicone, silica gel, brass

! Advisory note when used in conjunction with ALMEMO® 2890, 5690, 5790, 8590, 8690, 500, 809: The new ALMEMO® pressure measuring connector is very slightly higher (8.8 mm). As a result adjacent input sockets on the ALMEMO® device may be partly covered. However, the 1st input socket can always be used without restriction. Or, alternatively, the ALMEMO® pressure measuring connector can be plugged in at any input socket using connecting cable ZA9060AK1.

! On ALMEMO® devices to obtain precise measured results in m/s the wind tunnel temperature can be entered in the -50 to +700 °C range for compensation purposes.

### Accessories

	Order no.
ALMEMO® pressure measuring connector for barometric pressure 700 to 1100 mbar, without pressure terminal sleeve Technical data see chapter 10 Pressure including programming for automatic atmospheric pressure compensation (comment *P) (variant with pressure terminal sleeve, see chapter 10 Pressure)	<b>FDAD12SA</b> <b>OA9000PK</b>
Connecting cable, 0.2 meters	<b>ZA9060AK1</b>
Extension cable, 2 meters	<b>ZA9060VK2</b>
1 set of silicone hoses black / colorless, 2 meters	<b>ZB2295S</b>
Silicone hose, black, per meter	<b>ZB2295SSL</b>
Silicone hose, colorless, per meter	<b>ZB2295SFL</b>

### Variants (including manufacturer's test certificate)

	Order no.
(including one set of silicone hoses, 2 meters) Measuring ranges ±1250 Pa, Differential pressure (1 to 40 m/s), Measured variables: m/s, Pa, Measuring connector, independent of position	<b>FDA602S1K</b>
Measuring ranges ±6800 Pa Differential pressure (2 to 90 m/s) Measured variables m/s, Pa, Measuring connector, independent of position	<b>FDA602S6K</b>

## Pitot Tubes for Differential Pressure Sensors FDA602

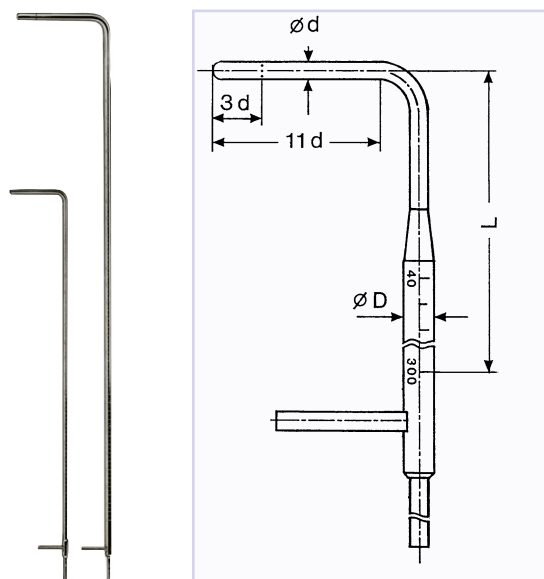

- Prandtl Pitot tubes with hemispheric head.
- For measuring the dynamic pressure, the tip of the Pitot tube has an opening of 0.3d.
- For measuring the static pressure, a total of 12 holes with 0.1d Ø have been arranged at a distance of 3d.
- Pitot tube coefficient 1.0. Accuracy typ. ±0.5 %



Mit ALMEMO® devices that have an option for entering factors can also be used to perform wind velocity measurements with cylindrical probes, according to VDEH. The cylindrical Pitot tubes have a probe-related coefficient of 1.7. By entering a factor of 0.767 in the range m/s this coefficient will be considered during the measurement.

### Option

Movable screw connection for brass Pitot tubes with shaft diameter x (6; 8; 10; 20mm)  
for steel Pitot tubes with shaft diameter x (6; 8; 10; 20mm)

### Order no.

ZB9912KMx  
ZB9912KVx

### Types and Technical Data:

Head Diameter (d)	Shaft Diameter (D)	Length	Tmax	Permiss. Dust	Material	Order no.
3 mm	6 mm	300 mm	150°C	none	Nickel-plated brass	FD991233MS
3 mm	6 mm	300 mm	300°C	none	Chrome-nickel steel	FD991233VA
5 mm	8 mm	400 mm	350°C	none	Nickel-plated brass	FD991254MS
5 mm	8 mm	400 mm	500°C	none	Chrome-nickel steel	FD991254VA
5 mm	8 mm	600 mm	350°C	none	Nickel-plated brass	FD991256MS
5 mm	8 mm	600 mm	500°C	none	Chrome-nickel steel	FD991256VA
8 mm	8 mm	400 mm	350°C	low	Nickel-plated brass	FD991284MS
8 mm	8 mm	400 mm	500°C	low	Chrome-nickel steel	FD991284VA
8 mm	8 mm	800 mm	350°C	low	Nickel-plated brass	FD991288MS
8 mm	8 mm	800 mm	600°C	low	Chrome-nickel steel	FD991288VA
10 mm	10 mm	800 mm	350°C	some	Nickel-plated brass	FD991296MS
10 mm	10 mm	800 mm	600°C	some	Chrome-nickel steel	FD991296VA*
10 mm	10 mm	1000 mm	350°C	some	Nickel-plated brass	FD991297MS
10 mm	10 mm	1000 mm	600°C	some	Chrome-nickel steel	FD991297VA*
10 mm	20 mm	1500 mm	350°C	some	Nickel-plated brass	FD991298MS
10 mm	20 mm	1500 mm	600°C	some	Chrome-nickel steel	FD991298VA*
20 mm	20 mm	2000 mm	600°C	more	Chrome-nickel steel	FD991299VA*

\*) all VA Pitot tubes can be operated up to 700°C for a short period